

NG1 - NG3

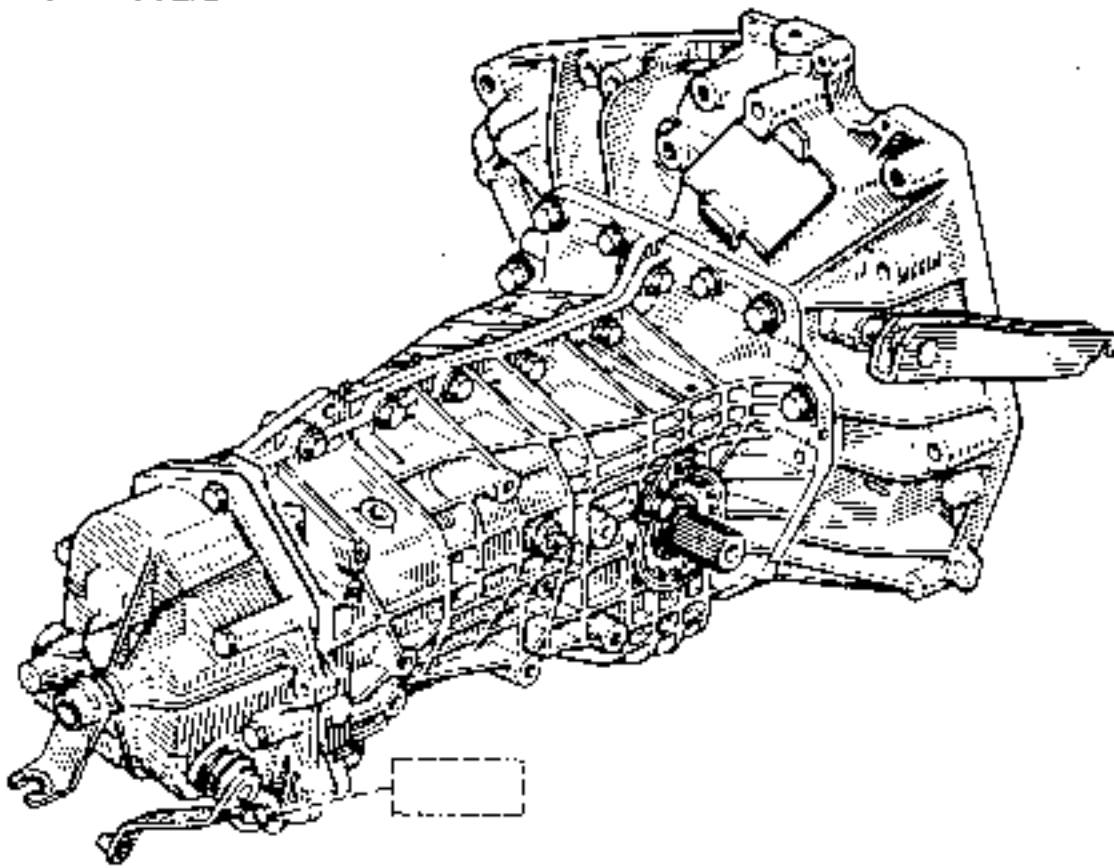

NG5

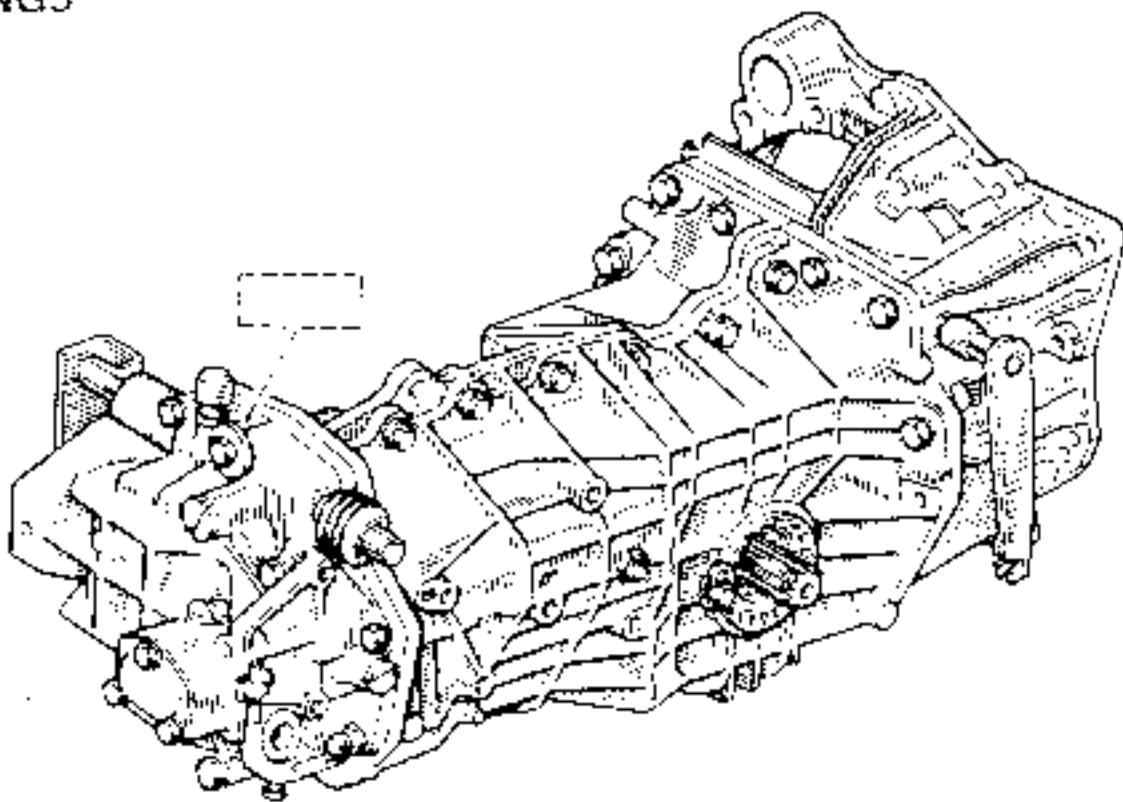

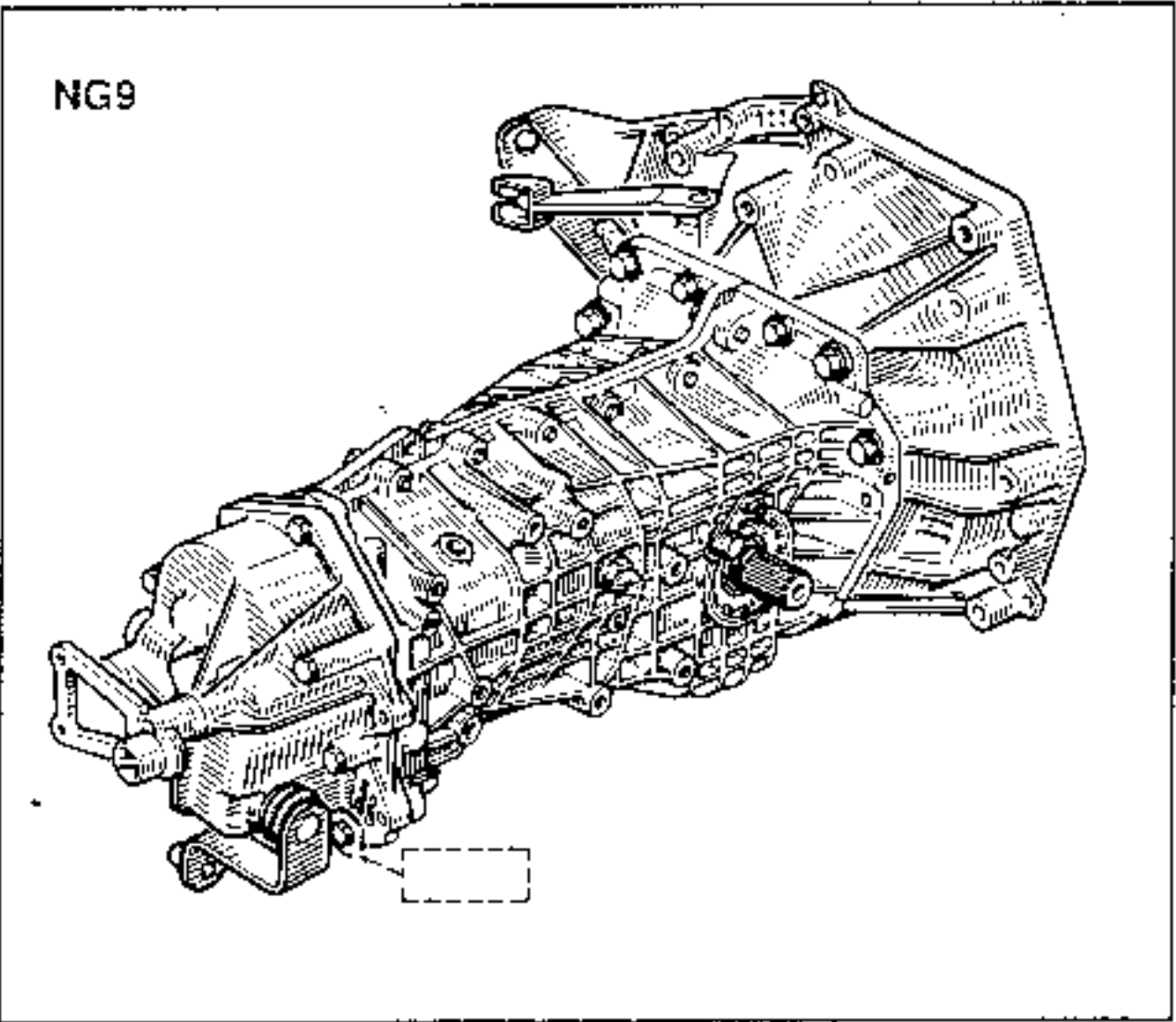
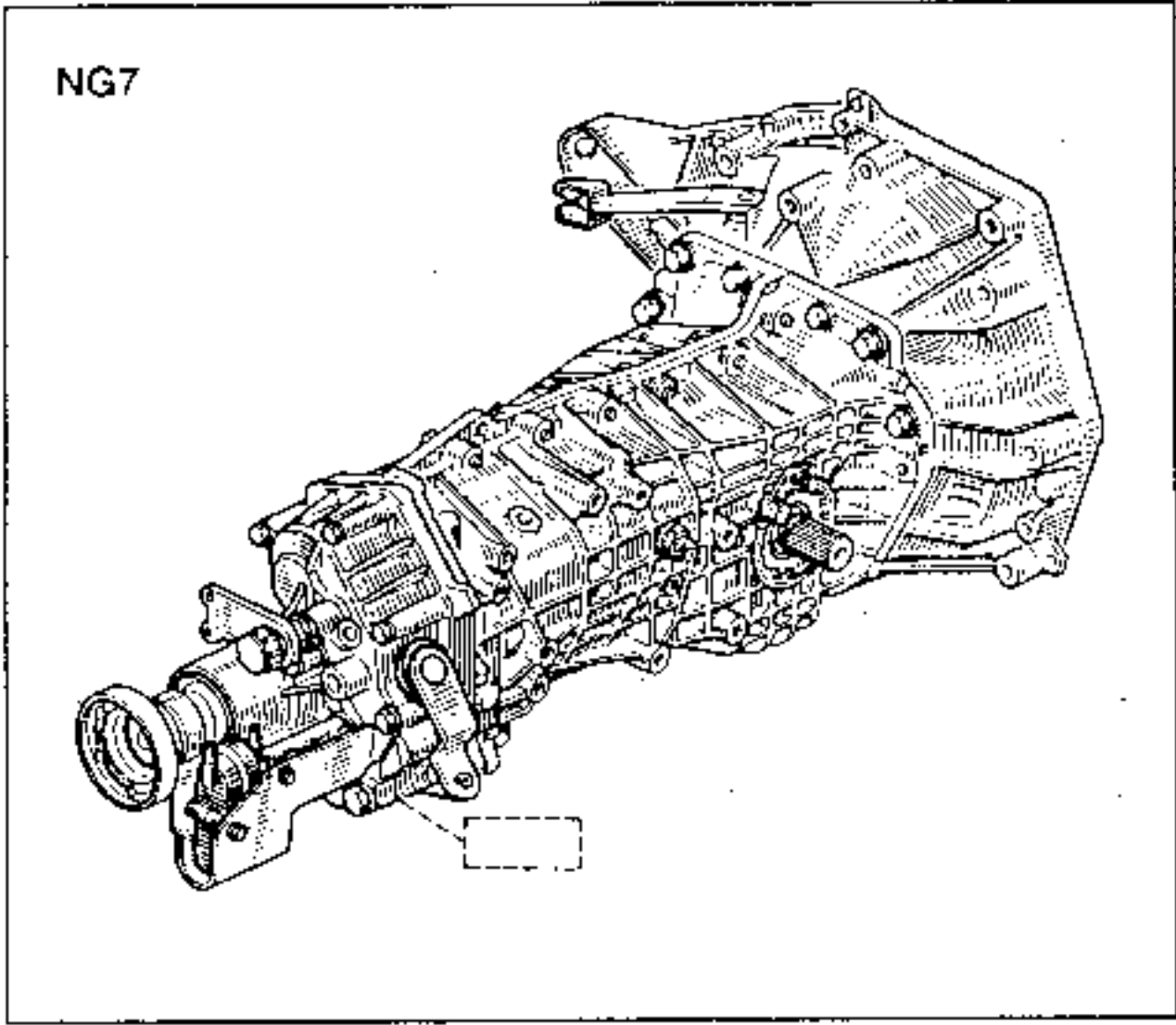

IDENTIFICATION

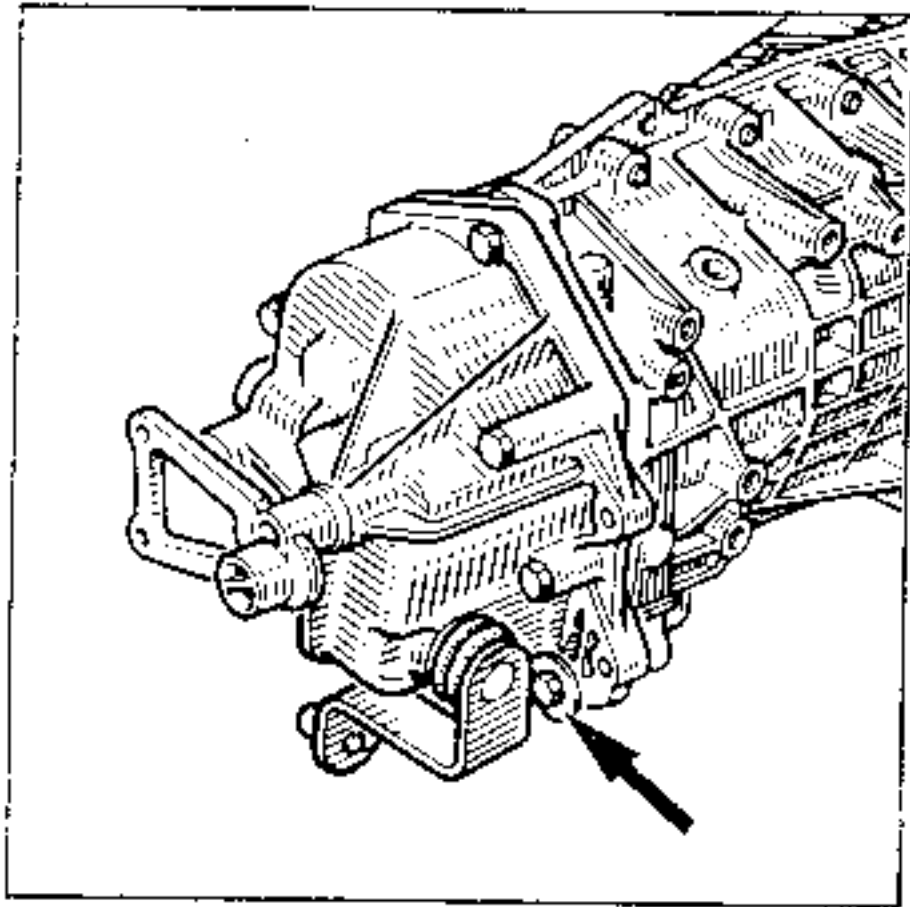

SPECIFICATIONS

- Light alloy casing, cast under pressure, consisting of two half casings joined by a vertical and longitudinal joint face. The rear casing houses the fifth gear.
- Four or five synchronized forward gears:
 - 1st/2nd: RENAULT synchro
 - 3rd/4th/5th: BORG-WARNER synchro
- One reverse gear.
- NG7: one longitudinal driveshaft dog clutch system.

A plate is mounted on the rear casing and shows:

- at A: the gearbox type
- at B: the gearbox suffix
- at C: the fabrication number
- at D: the manufacturing factory

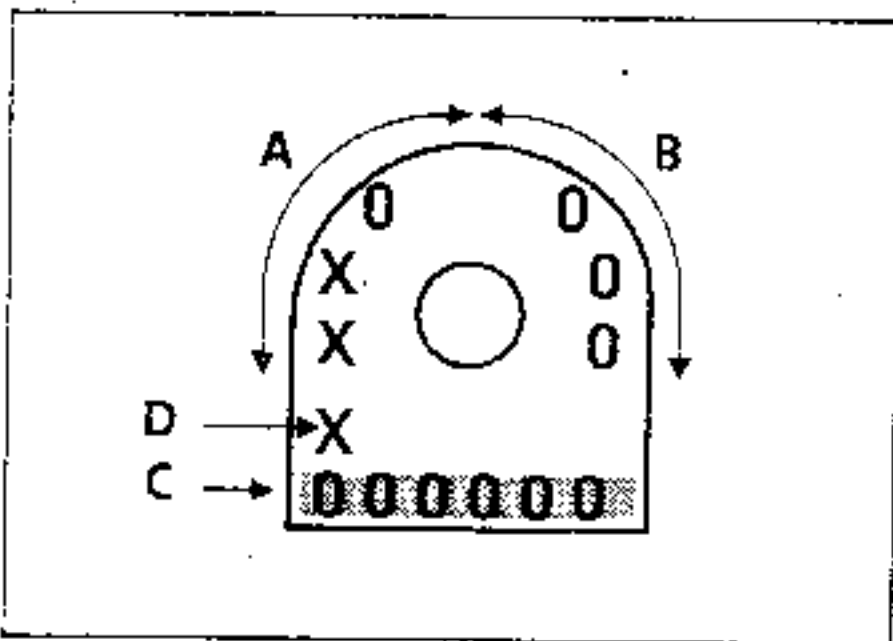

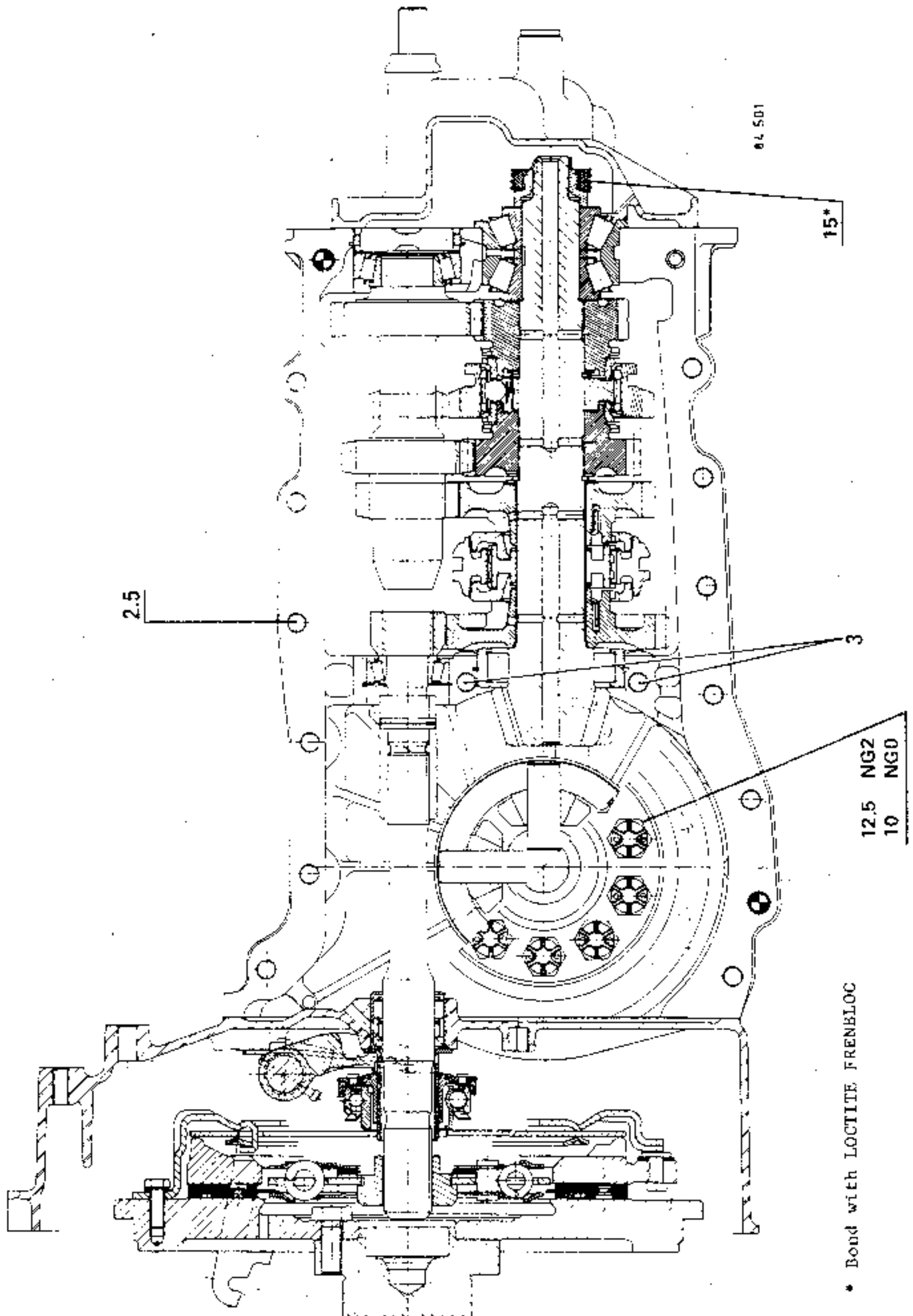

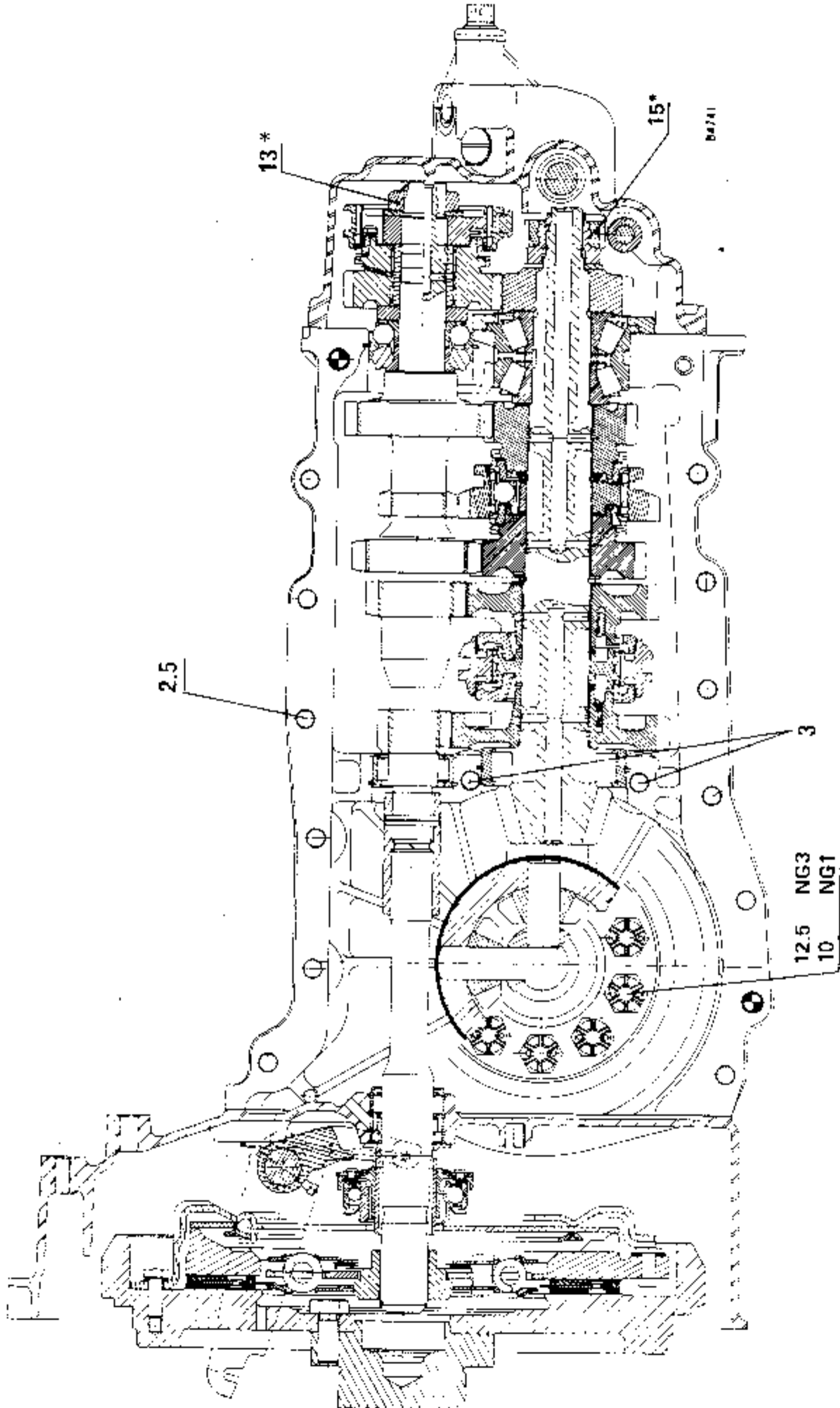

* Sond with LOCTITE FRENBLLOC

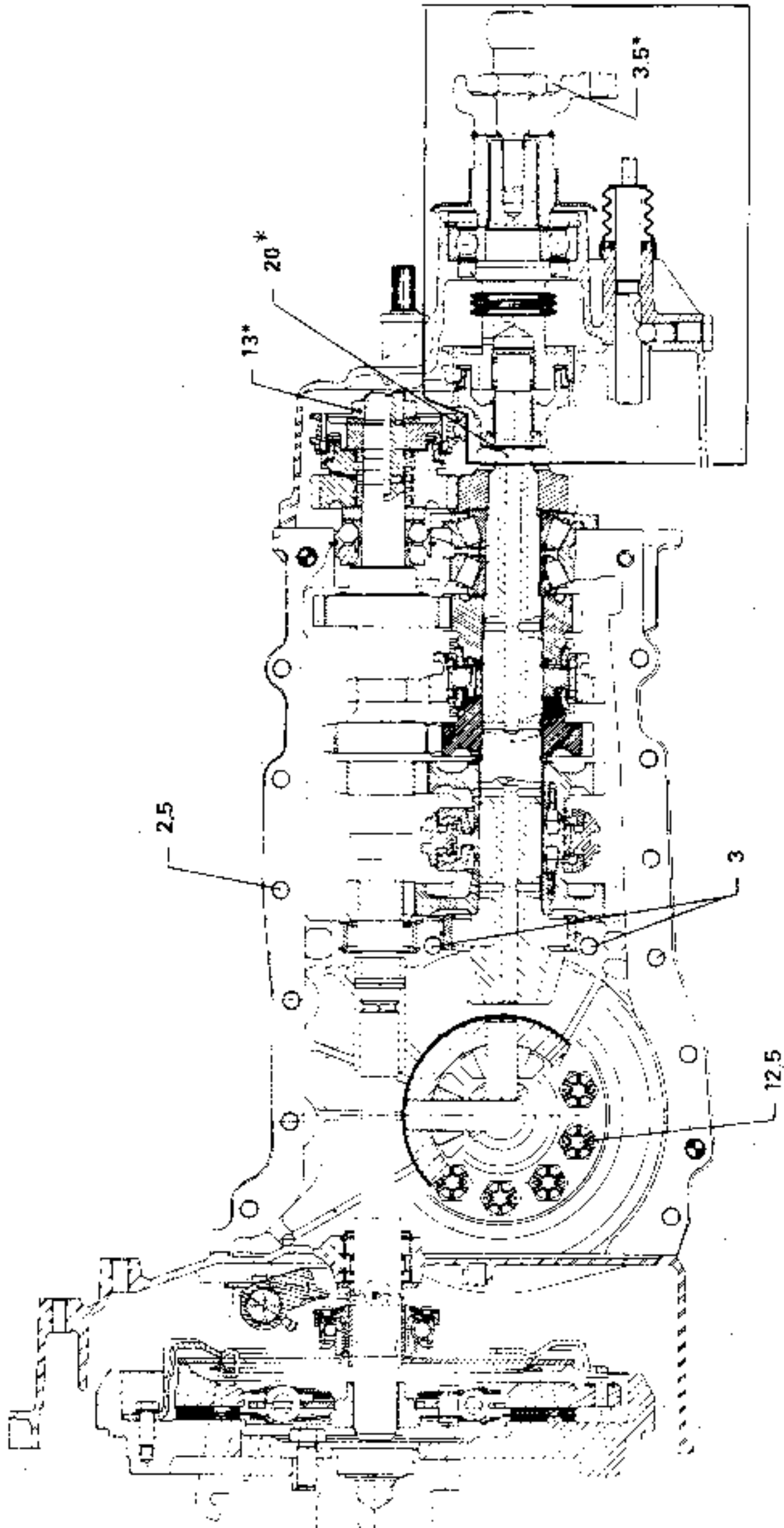

* Bond with LOCTITE FRENBLLOC

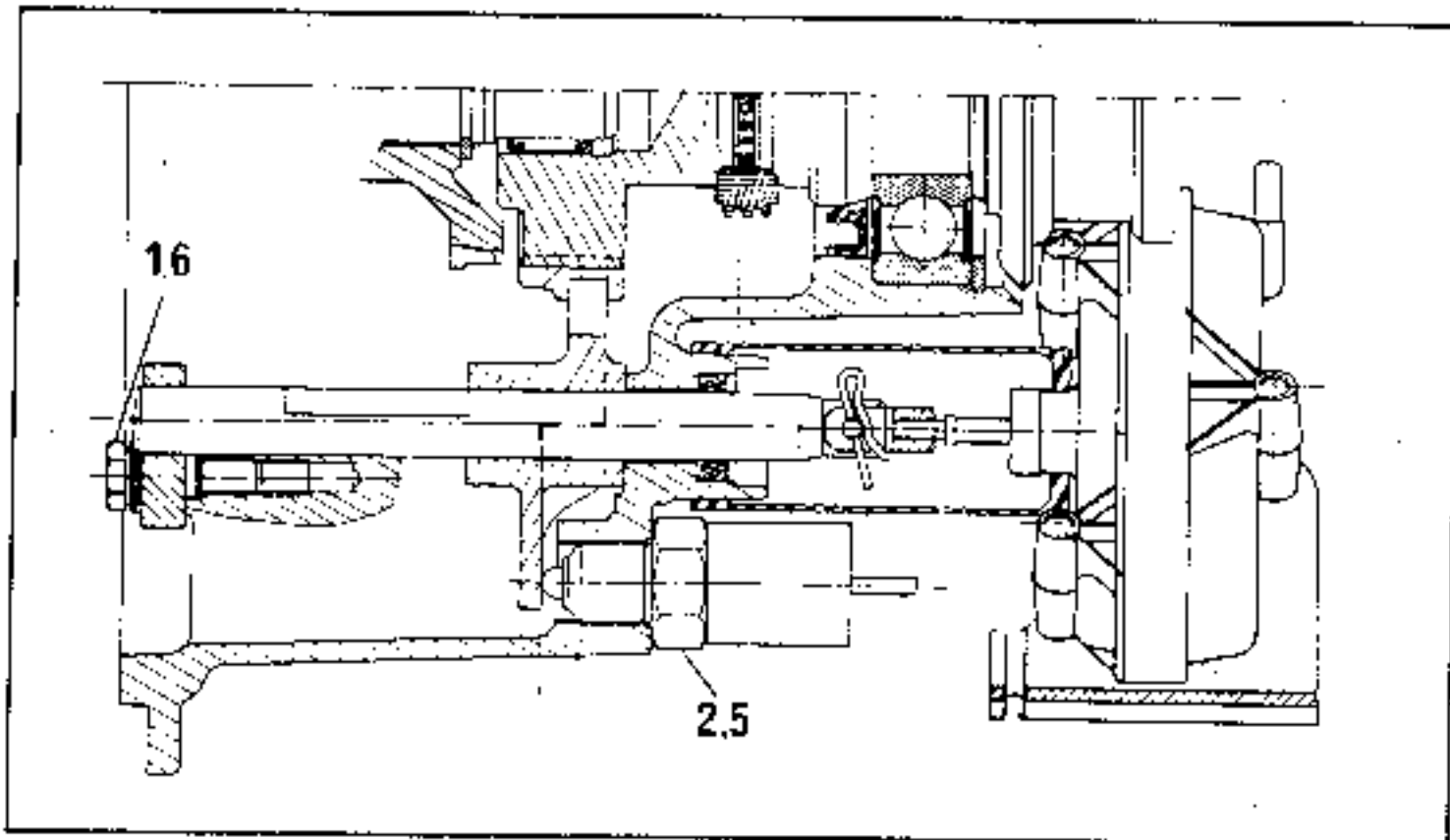
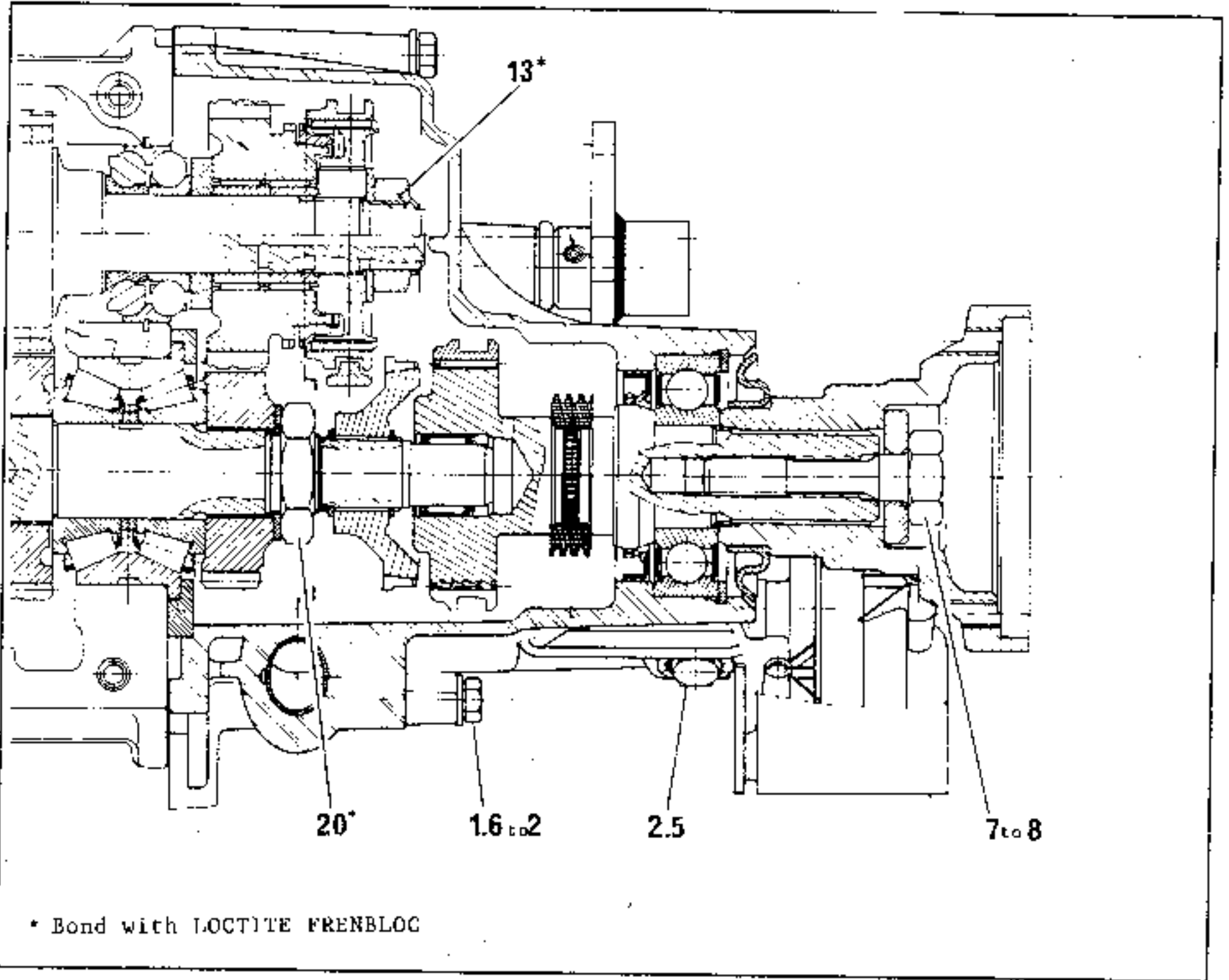

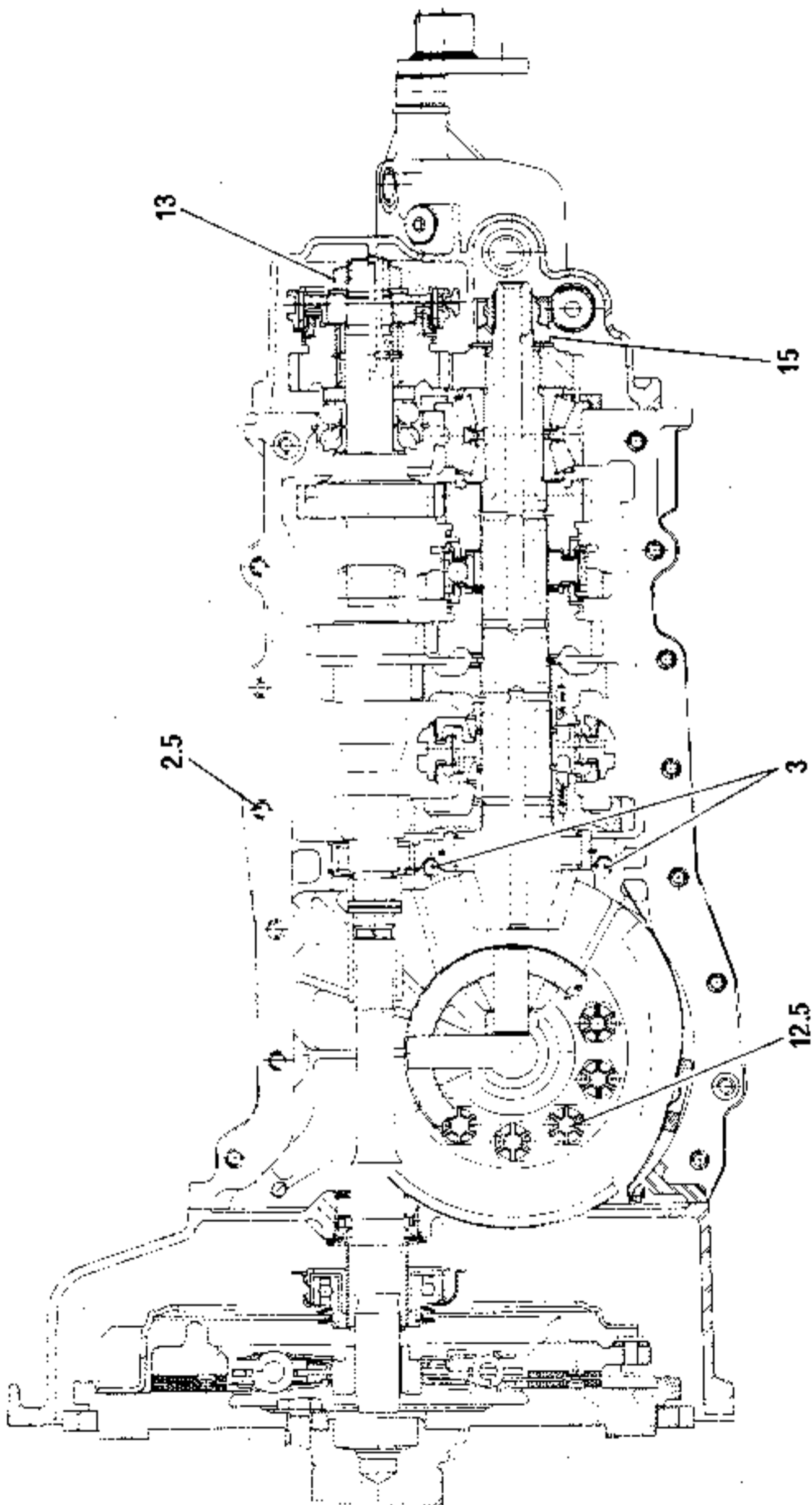

• Bond with LOCTITE FRENBLOC

NGO

SUFFIX	VEHICLE	FINAL DRIVE	SPEEDO DRIVE	1st	2nd	3rd	4th	REVERSE																		
001	1340 1360	9/34	5/17	11/42	17/37	22/31	34/33	$\frac{12}{37}$ 19																		
002	1350						33/34																			
003	1340 1360		34/33																							
004	1362		6/20																							
006	1271	33/34																								
009	1344 1354	9/31	6/18				11/42		17/37	22/31	34/33	$\frac{11}{39}$ 23														
010	1362	9/34	6/20																							
011	1341 1351												5/17													
015	1350		33/34																							
016	1344 1354	9/31	6/18										11/42	17/37	22/31	34/33	$\frac{11}{39}$ 23									
019	1271	9/34	6/20																							
020	1340 1350 1360 2350	9/32	5/16															11/42	17/37	22/31	33/34	$\frac{11}{39}$ 23				
	021			1340 1350 1360	34/33																					
023		1340 1350 2350	9/34	5/17	11/42	17/37		22/31													33/34		$\frac{11}{39}$ 23			
	025	1344 1354 2354																			9/31			6/18	11/42	17/37
026		1344 1354	9/34	6/20																						
	027	1362																			9/34			6/20		
028	1362																									

NG0

SUFFIX	VEHICLE	FINAL DRIVE	SPEED DRIVE	1st	2nd	3rd	4th	REVERSE
034	1340	9/32	5/16					
	1350							
035	1340							
	1350							
037	1360	9/34	5/17	11/45	17/37	22/31	34/33	$\frac{11}{39}^{23}$
	2350							
039	1344	9/31	6/18					
	1354							
040	2354							
	1344							
	1354							

NG2

SUFFIX	VEHICLE	FINAL DRIVE	SPEED DRIVE	1st	2nd	3rd	4th	REVERSE
000	1277	9/34	6/20					$\frac{12}{37}^{19}$
	1272							
017	1277			11/42	17/37	22/31	34/33	
	1272							
018	1277	9/31	6/18					$\frac{11}{39}^{23}$
042	1277	9/34	6/20	11/45				

NG1

SUFFIX	VEHICLE	FINAL DRIVE	SPEED DRIVE	1st	2nd	3rd	4th	5th	REVERSE
002	1340 1350 1360	9/34	5/17	11/42	17/37	22/31	33/34	36/31	$\frac{12}{37}^{19}$
003	1362		6/20						
006	1344 1354	9/31	6/18						
007	1276	9/34	6/20						
009	1341 1351								
010	1344 1354								
012	1340 1350 1360								
013	1362								
014	1344 1354	9/31	6/18						
018	1276	9/34	6/20						
022	1340 1350 1360 2350	9/32	5/16						
023	1340 1350 1360								
024	1340 1350 2350	9/34	5/17						
027	1341 1351	9/31	6/19						
028	1341 1351 1342	9/34	6/20						
029	1341 1351	9/31	6/19						

$\frac{11}{39}^{23}$

NG1

SUFFIX	VEHICLE	FINAL DRIVE	SPEEDO DRIVE	1st	2nd	3rd	4th	5th	REVERSE	
030	1342	9/34	6/20	11/42	17/37	22/31	33/34	36/31	$\frac{11}{39}^{23}$	
031	1344 1354 2354	9/31	6/18							
032	1344 1354									
033	1362	9/34	6/20							
034	1342 1352 1362									
040	1271	9/29	8/23							11/45
041	1341 1351 1361	9/31	6/19							
046	1344 1354		6/18							
048	1341 1351 1361	9/32	6/19	11/45	17/37	22/31	33/34	36/31	$\frac{11}{39}^{23}$	
051	1340 1350 1360 2350		5/16							
052	1340 1350 1360		9/34							5/17
053	1340 1350 2350									
054	1341 1351									
055	1341 1351	9/31	5/17							
056	1344 1354		6/18							

NG1

SUFFIX	VEHICLE	FINAL DRIVE	SPEED DRIVE	1st	2nd	3rd	4th	5th	REVERSE
057	1342 1352 1362	9/34	6/20	11/45	17/37	22/31	33/34	36/31	$\frac{11}{39}^{23}$
060	1276								
061	1344 1354 2354	9/31	6/18				34/33	37/29	
068	B296	9/34					33/34	36/31	
078			6/19						

NG3

SUFFIX	VEHICLE	FINAL DRIVE	SPEED DRIVE	1st	2nd	3rd	4th	5th	REVERSE					
000	1363	9/34	6/20	11/42	17/37	22/31	33/34	36/31	$\frac{12}{37}^{19}$					
001	1345													
005	1277 1272													
008	1270	9/32	6/18						11/42	17/37	22/31	33/34	36/31	$\frac{11}{39}^{23}$
010	1272	9/34	6/20											
011	1345													
015	1277	9/31	6/18											
016	1277 1272	9/34	6/20											
019	1270	9/32	6/18											
020	1343 1353	9/31												
021	1343 1353 1363	9/34	6/20											
025	1365													

NG3

SUFFIX	VEHICLE	FINAL DRIVE	SPEEDO DRIVE	1st	2nd	3rd	4th	5th	REVERSE
039	1366 J115	9/31	6/18	11/45	17/37	22/31	34/33	37/29	$\frac{11}{39}^{23}$
042	1345 1355	9/34	6/20						
043	1345 1355 1365								
044	1343 1363 J112								
045	1270	9/32	6/18						
047	1277	10/31	8/22						
062	1277	9/34	6/20						
063	1343 1353 J112 S112	9/31	6/18						
064	1363	9/34	6/20						
067	B297	9/29							
069	B290	9/32							
072	B297 B29H	9/32							
073	B297 Suisse	9/34							
075	B297	9/29	8/22						
076	B297 B29H	9/32	6/18						
077	B297	9/34	6/19						
079	B29H B29B B29J	9/32	6/18						

NG3

SUFFIX	VEHICLE	FINAL DRIVE	SPEED DRIVE	1st	2nd	3rd	4th	5th	REVERSE			
083	B29H B29B B29J	9/32		11/45	17/37	22/31	33/34	36/31	$\frac{11}{39} \cdot 23$			
084	J-S112 J117	9/31	6/18									
085	J112	9/34	6/18									
087	J115 S115	9/31	6/18			28/43	37/43	43/40				
088	B292	9/32	6/18									
089	B292	9/32										
090	B29E	9/31				22/31	33/34	36/31				
091	J116	9/34	6/19									
092	B290	9/32	6/18									
093	B29J	9/32	6/18							34/33	37/29	

NG5

SUFFIX	VEHICLE	FINAL DRIVE	SPEEDO DRIVE	1st	2nd	3rd	4th	5th	REVERSE	
000	1223 Alpine	8/31	6/14	11/42	17/37	22/31	33/34	36/31	$\frac{12}{37}^{19}$	
001	1223 Coupe	8/33								
002	1223 Gordini	8/31								
003	122B	9/34	6/13						$\frac{11}{39}^{23}$	
004	122B									
005	122B									
006	122B									
007	1223 Alpine	8/31	6/14							$\frac{12}{37}^{19}$
008	1223 Coupe	8/33								
009	1223 Gordini	8/31								
010	122B	9/34	6/13						11/45	
011	122B									
012	122B									
013	122B			11/42						

NG7

SUFFIX	VEHICLE	FINAL DRIVE	SPEEDO DRIVE	1st	2nd	3rd	4th	5th	REVERSE
000	1351	9/34	6/20	11/45	17/37	22/31	34/33	37/29	$\frac{11}{39}^{23}$
001	1354								
002	1353								
003	K483 K48K	9/31	6/18						
004	K486						33/34	36/31	
005	J117 J116	9/34	6/19						

NG9

SUFFIX	VEHICLE	FINAL DRIVE	SPEEDO DRIVE	1st	2nd	3rd	4th	5th	REVERSE
000	L-K483 L 489 L-K 48K	9/31	6/18	11/45	17/37	22/31	33/34	36/31	$\frac{11}{39}^{23}$
001	L-K488	9/31	6/18				34/33	37/29	
002	L-K-5486	9/29	8/23				33/34	36/31	
003	L-K48K	10/31	8/22				34/33	37/29	
005	L489	9/34	6/19						
006	L-K486 Espagne	9/31	6/18				33/34	36/31	
007	L489 Arabie	9/32	6/19						
008	L-K48S	9/31	6/18						

NG GEAR RATIOS FOR USA AND CANADA

NG0

SUFFIX	VEHICLE	FINAL DRIVE	SPEED DRIVE	1st	2nd	3rd	4th	REVERSE
012	1341	9/34	6/20	11/42	17/37	22/31	34/33	$\frac{12}{37}^{19}$
	1348							
024	1351	9/31	6/19	11/45	17/37	22/31	34/33	$\frac{11}{39}^{23}$
	1358							
038	1341	9/31	6/19	11/42	17/37	22/31	34/33	$\frac{11}{39}^{23}$
	1348							
041	1351	9/31	6/19	11/45	17/37	22/31	34/33	$\frac{11}{39}^{23}$
	1358							

NG1

SUFFIX	VEHICLE	FINAL DRIVE	SPEED DRIVE	1st	2nd	3rd	4th	5th	REVERSE
004	1341	9/34	6/20	11/42	17/37	22/31	33/34	36/31	$\frac{12}{37}^{19}$
	1348								
030	1351	9/34	5/17	11/45	17/37	22/31	33/34	36/31	$\frac{11}{39}^{23}$
	1358								
037	1368	8/33	5/18	11/45	17/37	22/31	33/34	36/31	$\frac{11}{39}^{23}$
	1368								
055	1341	9/34	5/17	11/45	17/37	22/31	33/34	36/31	$\frac{11}{39}^{23}$
	1348								
058	1351	9/34	5/17	11/45	17/37	22/31	33/34	36/31	$\frac{11}{39}^{23}$
	1358								

NG GEAR RATIOS FOR USA AND CANADA
NG3

SUFFIX	VEHICLE	FINAL DRIVE	SPEED DRIVE	1st	2nd	3rd	4th	5th	REVERSE
065	136A	9/34	6/20	11/45	17/37	22/31	33/34	36/31	$\frac{11}{39}$ 23

NG9

SUFFIX	VEHICLE	FINAL DRIVE	SPEED DRIVE	1st	2nd	3rd	4th	5th	REVERSE
003	L-K48A	10/31	8/22	11/45	17/37	22/31	34/33	37/29	$\frac{11}{39}$ 23

CAPACITY (in litres)

NG0	2
NG2	
NG1	2.2
NG3	
NG9	
NG7	2.4

VISCOSITY

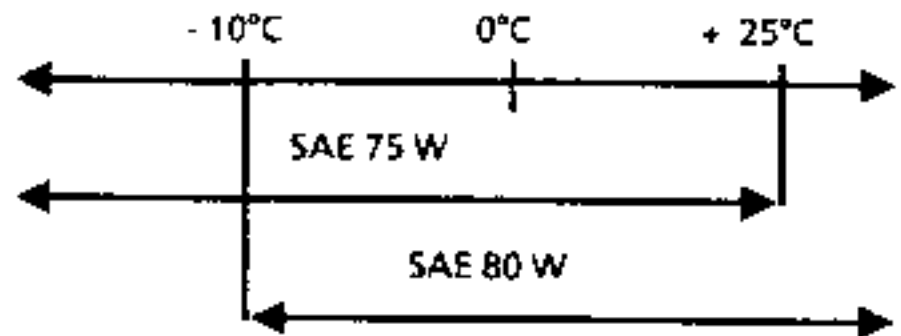

GRADE

In order to be more resistant to the high temperatures to which the B29E, B292 and Turbo petrol vehicles are subject, the gearboxes on these vehicles must be lubricated exclusively with the new "high temperature" oil approved by Renault:

TRANSELF TRX 80 W.

Therefore, two grades of oil are recommended:

VEHICLE	GRADE
NORMALLY ASPIRATED except B29E & B292	APIGL5 - MILL2105 B C
TURBO PETROL B29E B292	TRANSELF TRX 80 W*

(*) If you have any problems obtaining this oil locally, it can be ordered from the Parts Department under number 77 01 417 403 (only in 28 litre drums).

Drain: via plug (1).

Refill and check level: plug (2).

NOTE: On some versions, protection plate (3) must be removed to gain access to drain plug (1).

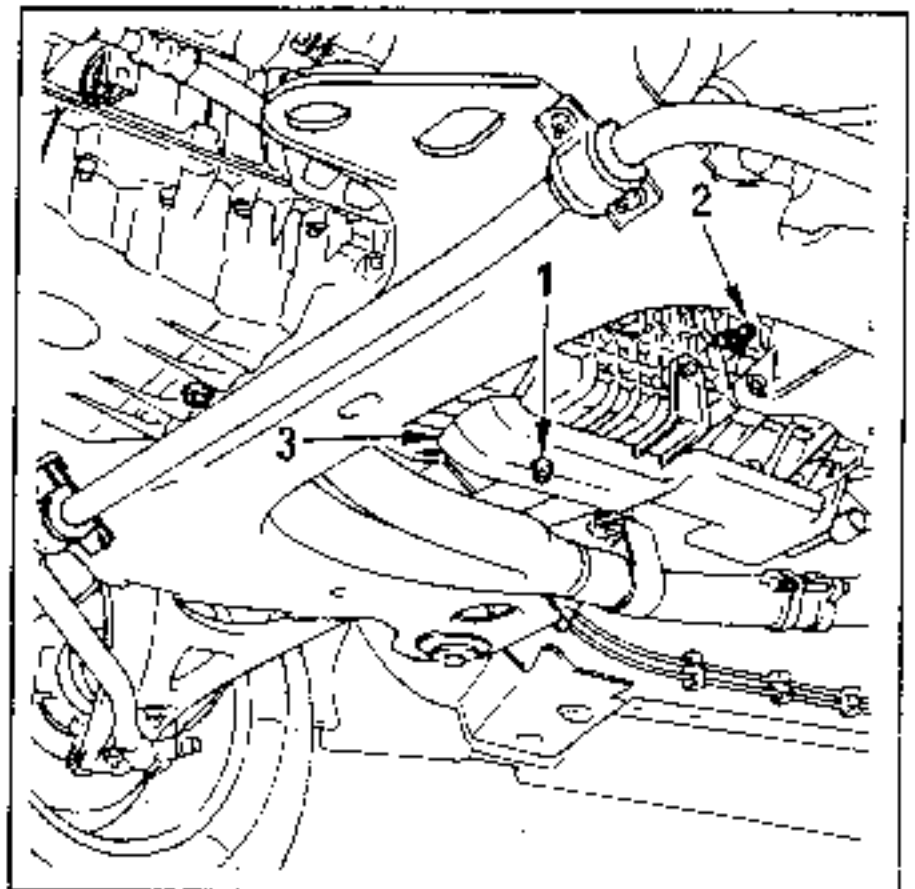

SPECIAL PRECAUTIONS

TRANSELF TRX 80 W oil is a high-technology product which requires certain precautions to be taken to prevent foreign bodies getting into it as they could damage the oil and make gear changing difficult.

STORING OIL DRUMS OUTSIDE

The drums must be stored sheltered from bad weather (rain, snow, where they might be splashed) and they must be stored horizontally.

STORING AND USING AN OPEN OIL DRUM

Particular attention should be paid to all drums which have been opened for use as regards their protection against the ingress of any material or liquid into the drum.

In particular:

- 1) Do not pierce the top of the drums, although this may be indicated on them.
- 2) Do not place containers holding liquid on the drums.
- 3) Do not leave drums outside.
- 4) If oil is removed using a syringe, the drum must be closed again after use.
- 5) Do not set a drum down near a washing bay.
- 6) If transferring oil to larger drums, ensure that they are completely clean beforehand.

PRESSURE WASHING

1) In situ:

Blank off the gearbox vent-to-atmosphere breather.

2) Gearbox removed:

All apertures connecting internally with the gearbox must be blanked off correctly to ensure that water does not get into the gearbox.

DIFFERENTIAL BEARING PRE-LOAD (daN)

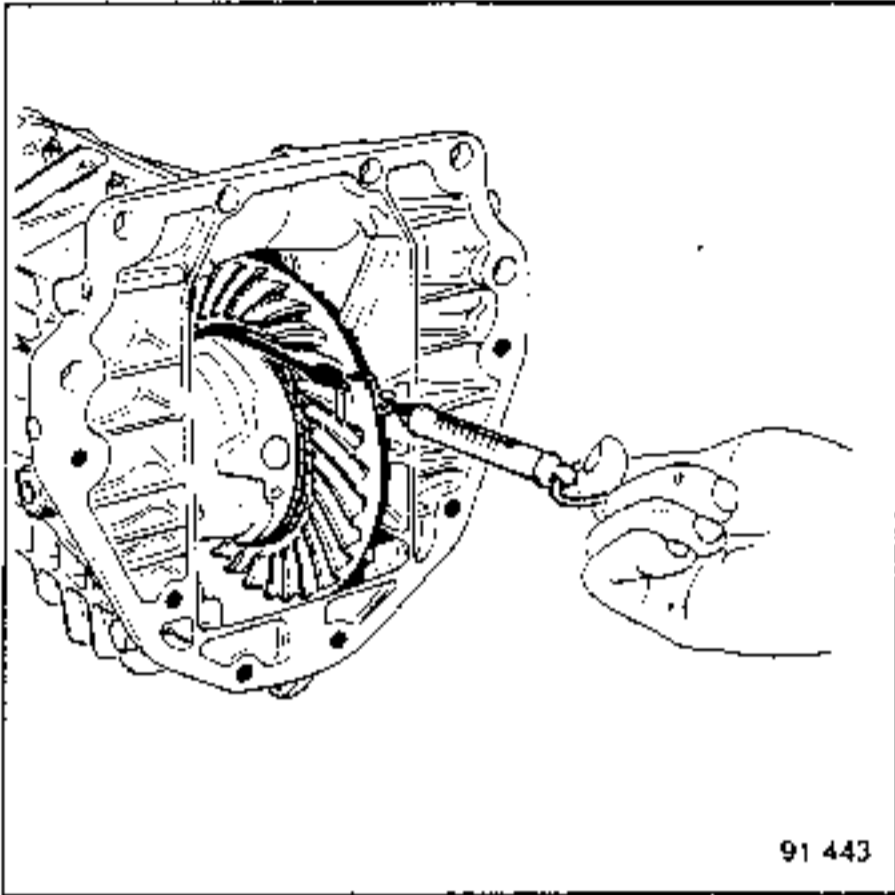

Re-used bearings	New bearings
Free turning without play	4 to 6 daN

BACKLASH

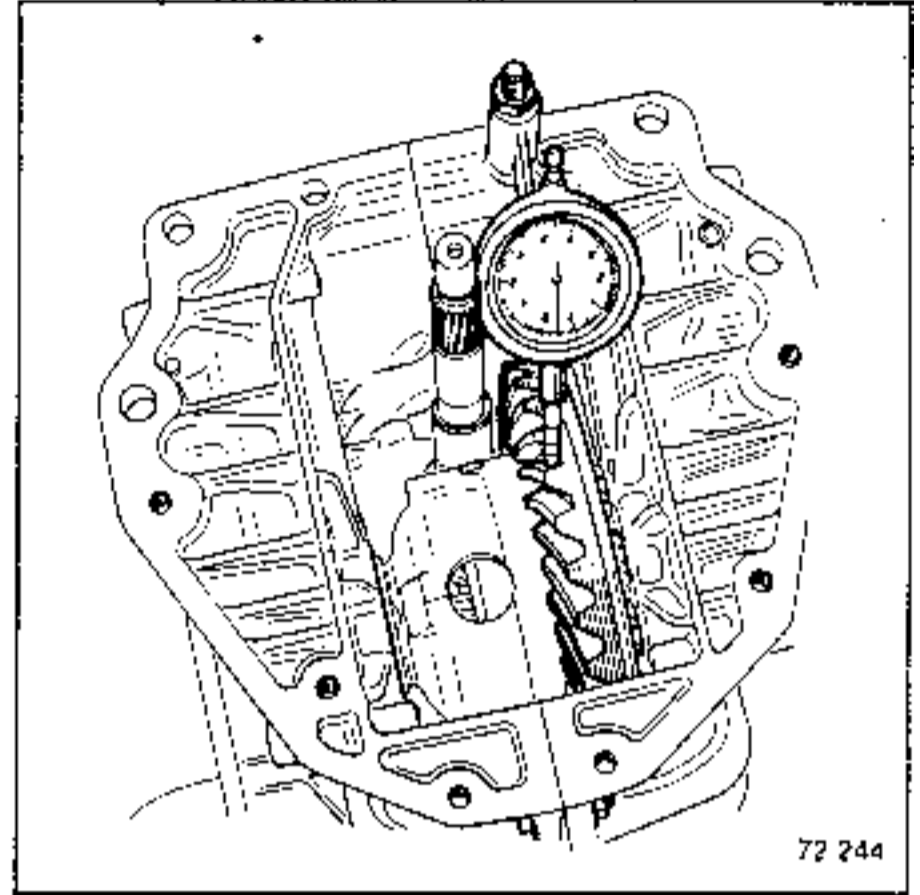

Backlash
0.12 to 0.25 mm

NG0 and NG2 PRIMARY SHAFT BEARINGS

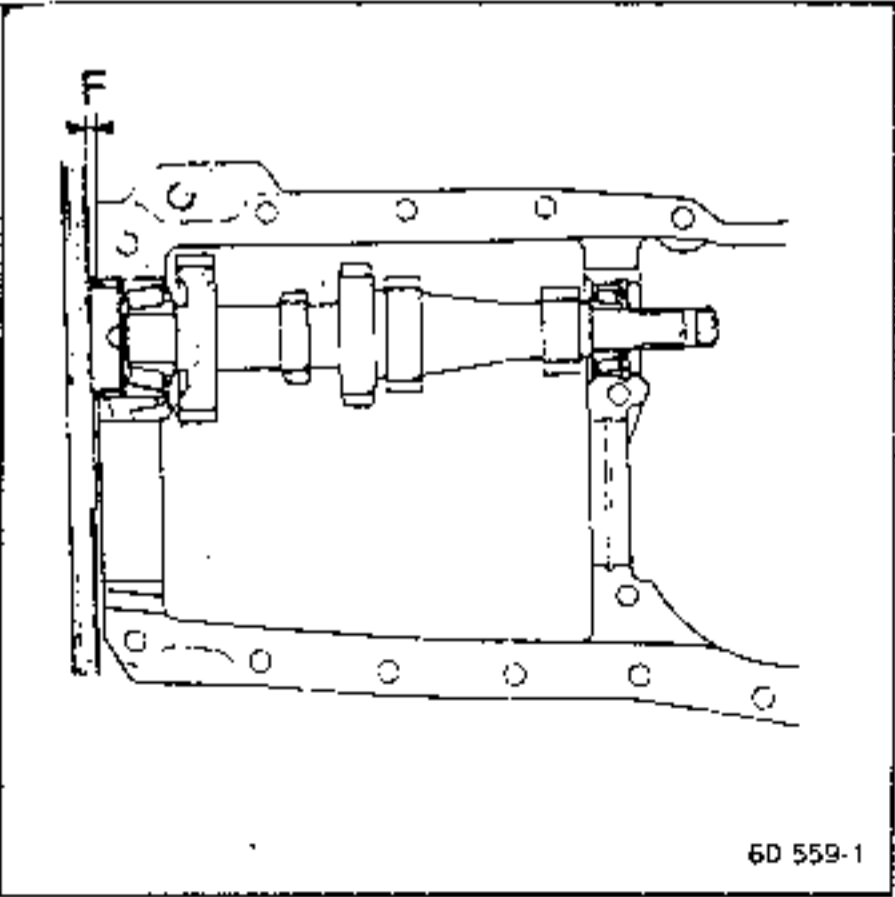

Clearance F = 0.02 to 0.12 mm

SELECTOR GRILLE

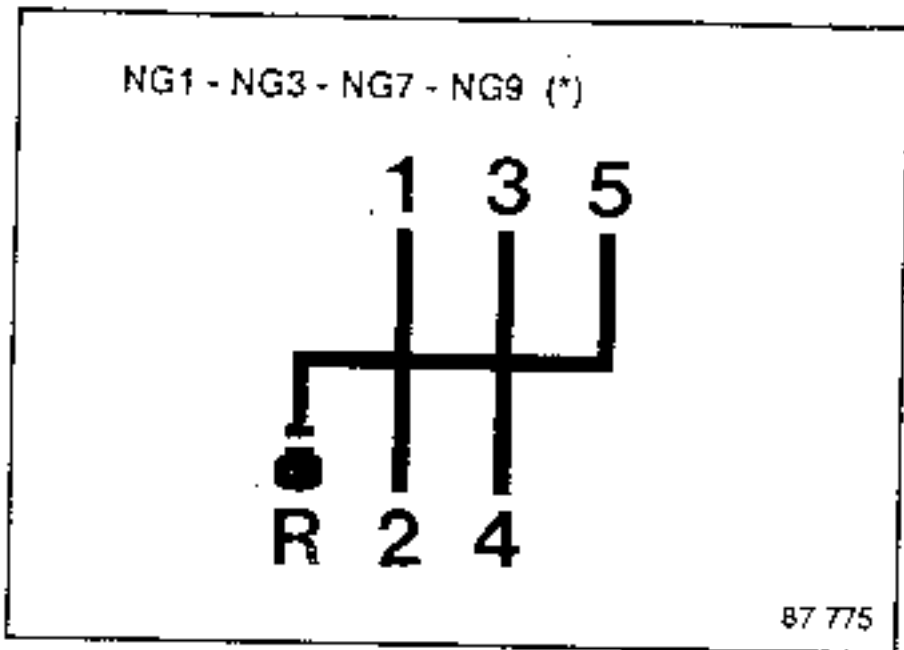
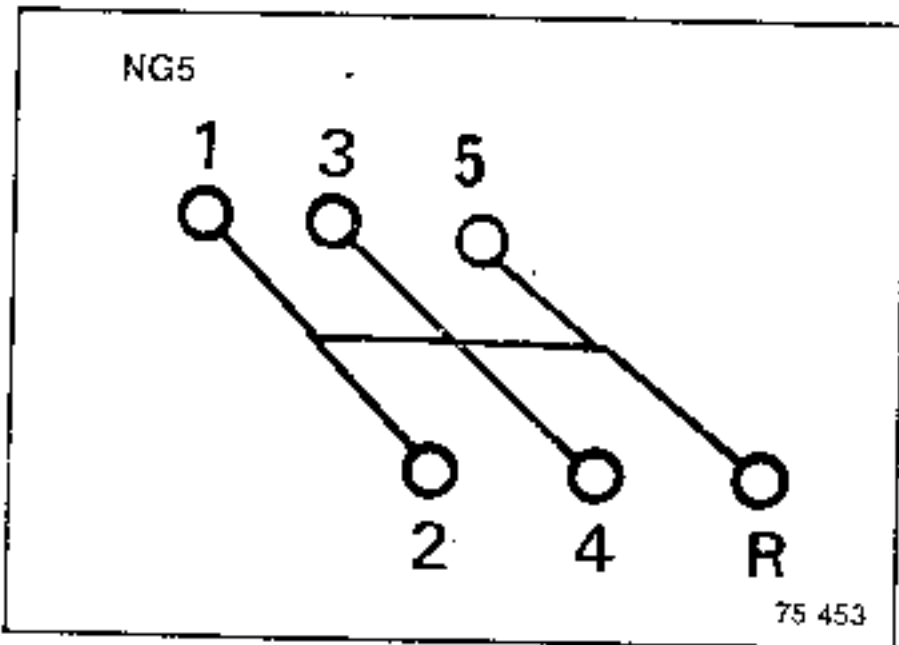
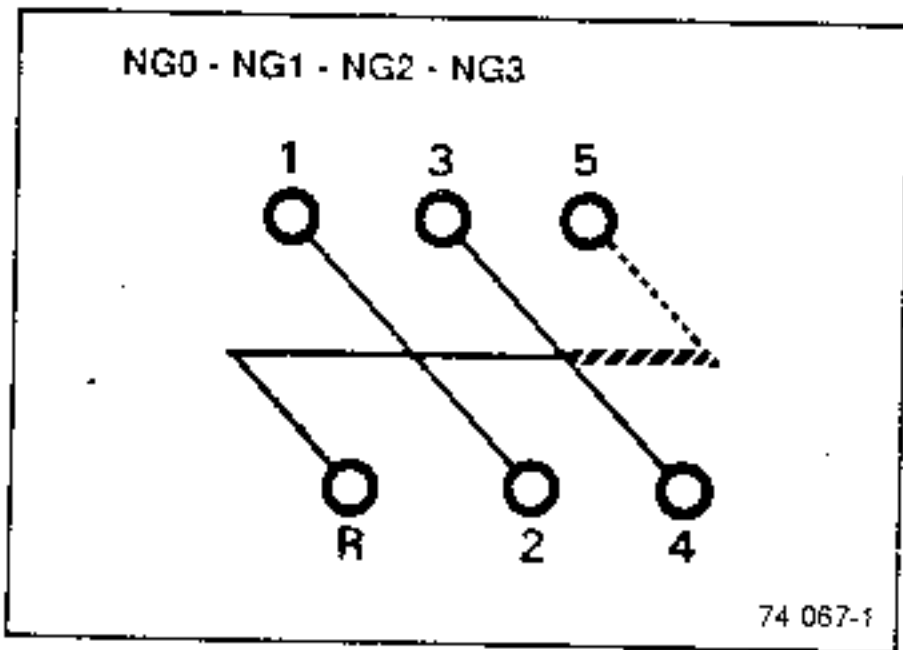

To select reverse, lift ring (A) so that it touches the knob and move the lever.

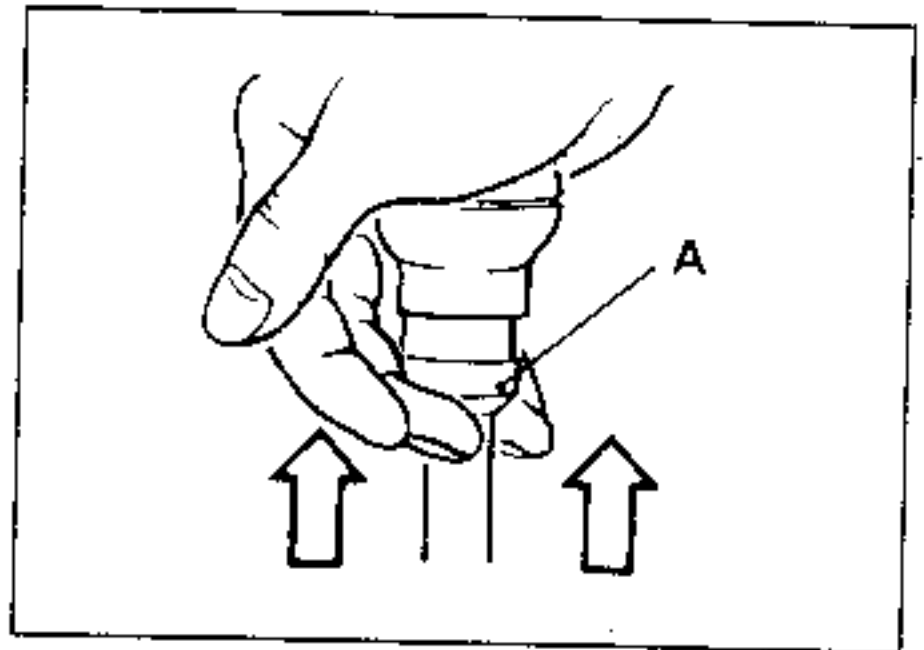

Composition

4 - speed	5 - speed	Differential number of planet wheels
NG0	NG1 - NG5	2
NG2	NG3 - NG9	4
	NG7	2
	NG7 003 and 005	4

*) Gearboxes with the reverse gear positive locking system

MATCHED PARTS

- Crown wheel and pinion.
- Synchro hub and slide gears
- Differential bearing race and track.

FINAL DRIVE MATCHING

The final drive and crown wheel are ground together during manufacture.

They cannot, therefore, be separated.

If one part is replaced then the other part has to be replaced too.

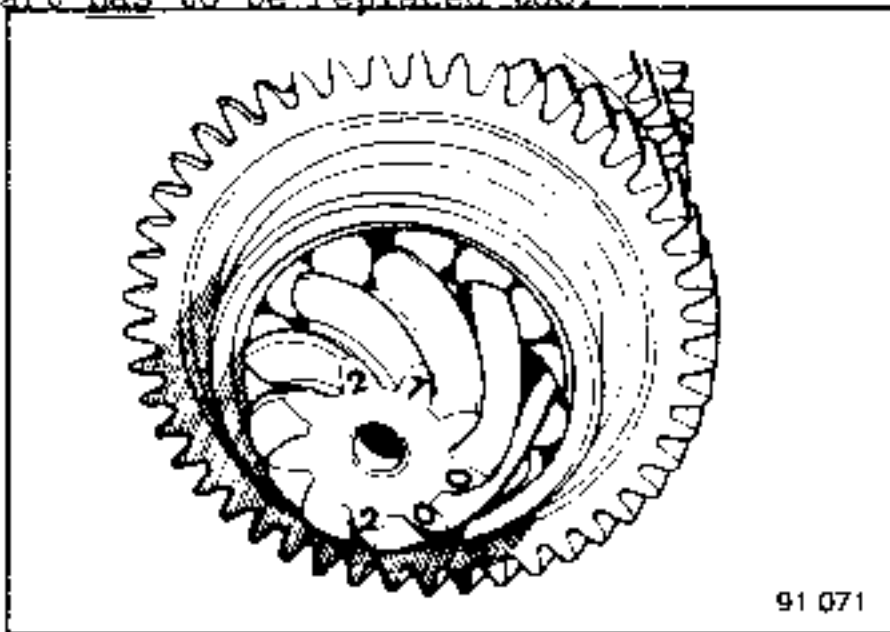

There is a common marking on the crown wheel and pinion.

For example: 27-200 (27th crown wheel machined on 200th day of the year).

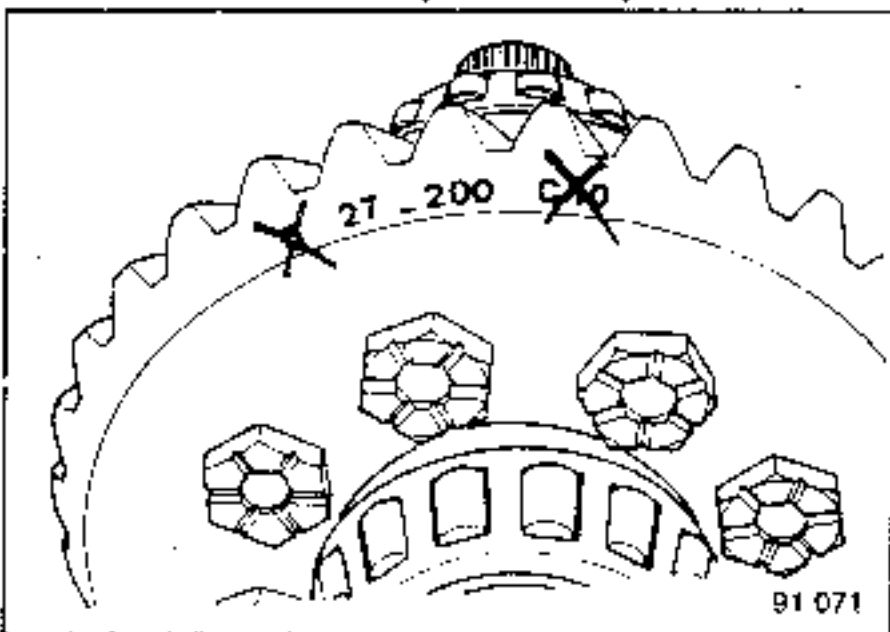

The backlash cannot be adjusted.

- the final drives on NG3 gearboxes can be cut in two different ways and fitted either way;
- electronic speedometer: the sensor ring gear cannot be dismantled.

MATCHING THE SYNCHRO HUB/SLIDE GEAR

In all cases, it is advisable to mark the slide gears in relation to the hubs.

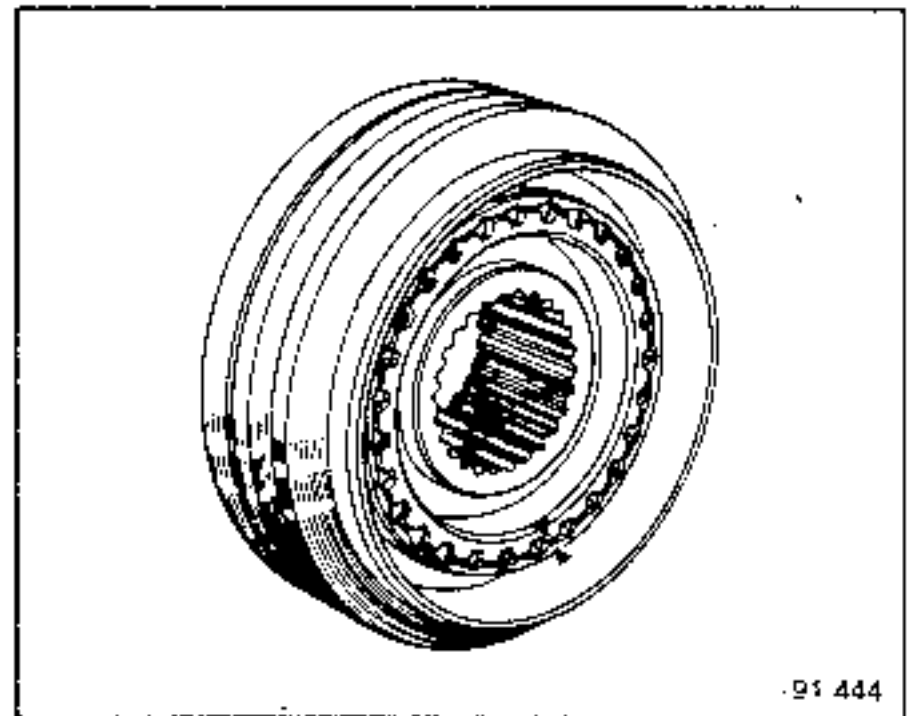

NG7:

The speedometer ring gear is moulded onto the hub (output shaft). If the ring gear is damaged the gearbox output shaft will have to be changed.

The gearbox output shaft lip seal can only be dismantled when the rear casing has been removed and the shaft and bearing control shafts dismantled.

Assembling the clevis pin on the vacuum capsule:

When replacing the vacuum capsule, ensure that the distance for locating the clevis pin on the control rod is correct:

$$X = 2 \text{ to } 3 \text{ mm}$$

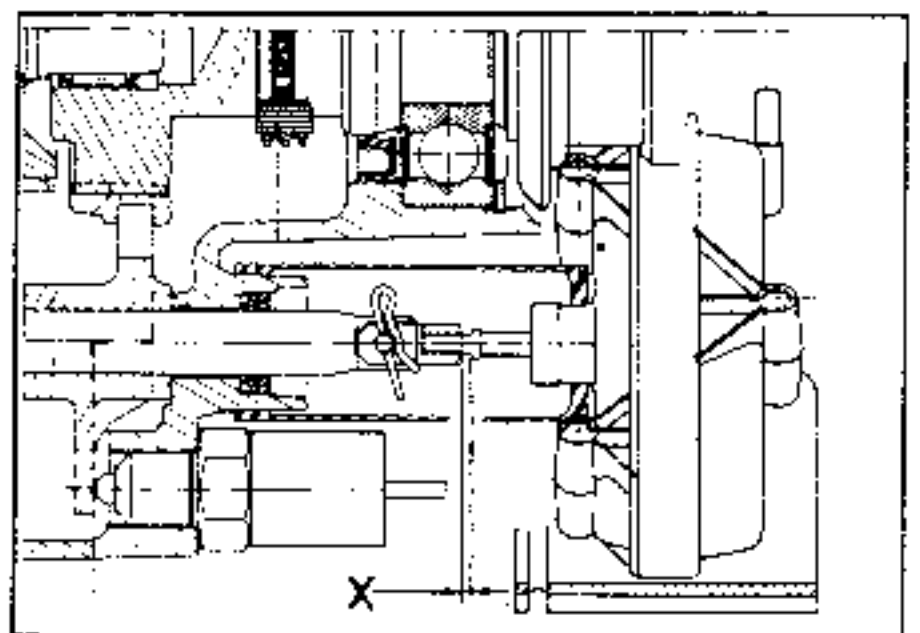

2ND GEAR SYNCHRO ASSISTANCE

This is a device enabling the quality of the 2nd gear change to be improved.

Operation

When changing into second gear, a proportion of the stress applied to the fork to move the slide gear is absorbed by spring (R) on the shaft, so as to enable the selector lever to move immediately but to retard the complete movement of the fork.

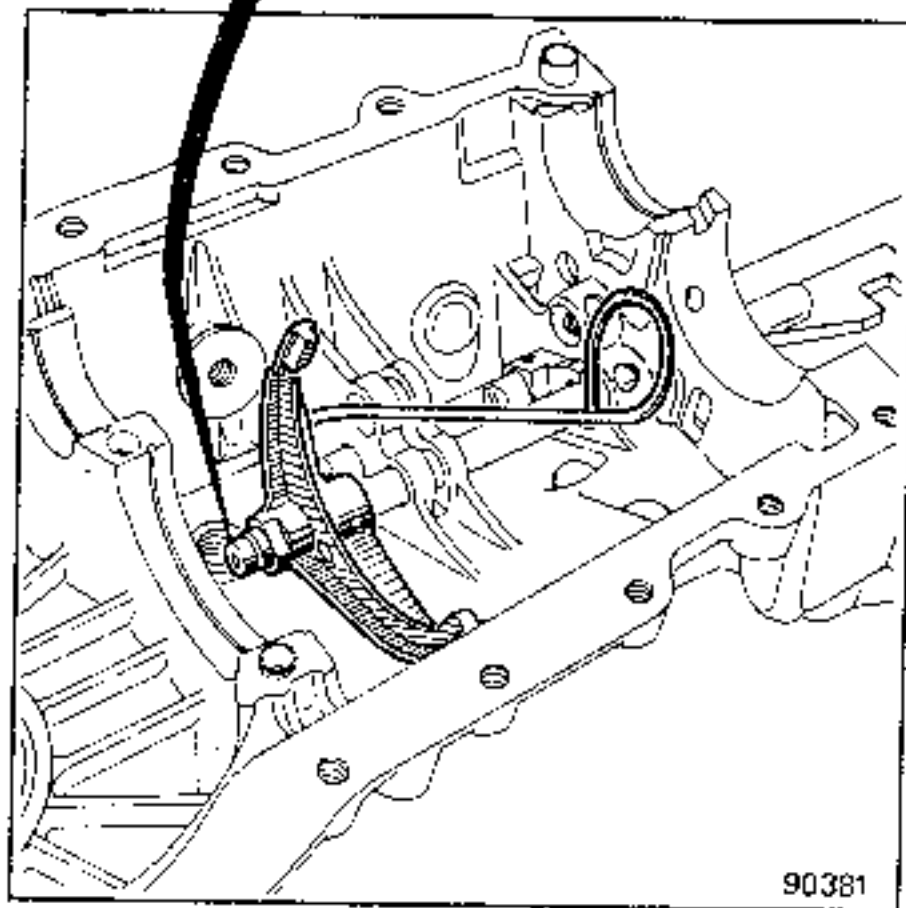
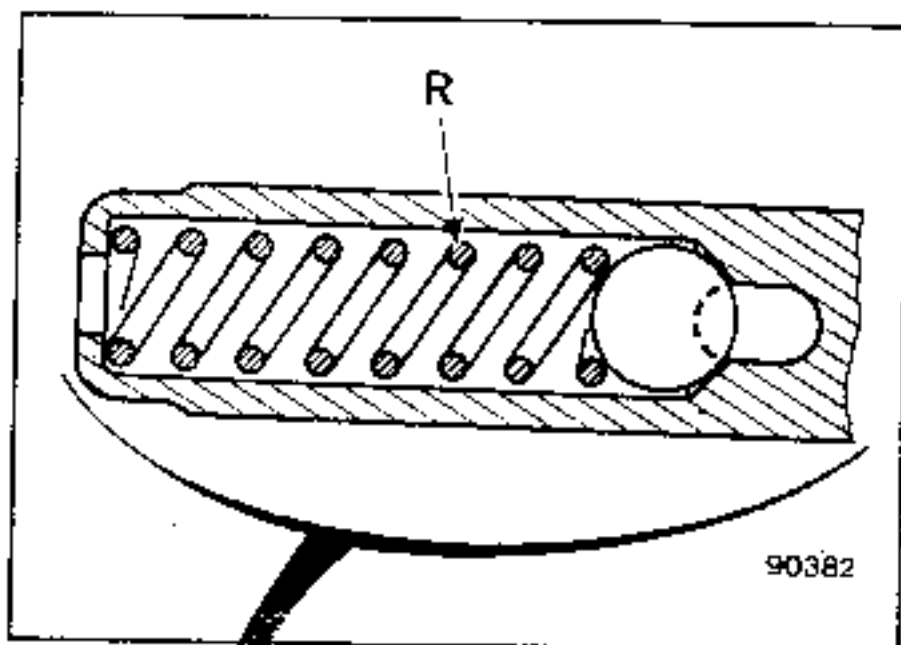

After fitting the rollpin, make sure that the fork slides on its shaft.

NOTE: In addition to this modification a 1st/2nd speed shaft locking plunger is fitted instead of a locking ball.

REVERSE GEAR POSITIVE LOCKING DEVICE

This system prevents reverse being engaged by mistake when changing quickly from 3rd to 2nd.

Operation

To select reverse, raise ring (A) and move the lever; the ring acts by means of a cable on the finger of a lock (V) mounted on the gearbox rear casing.

When this finger moves aside, reverse gear can be selected.

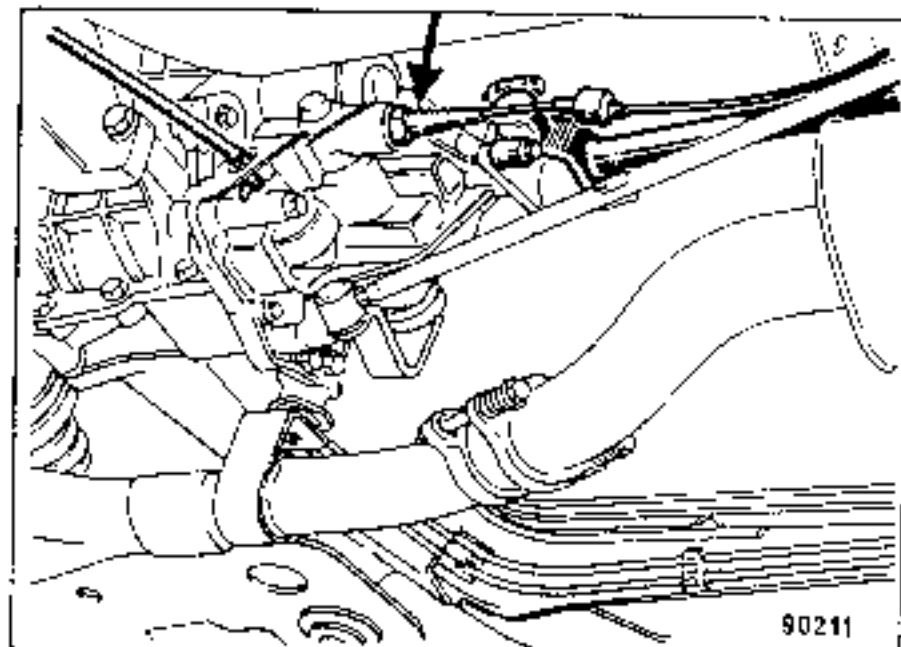
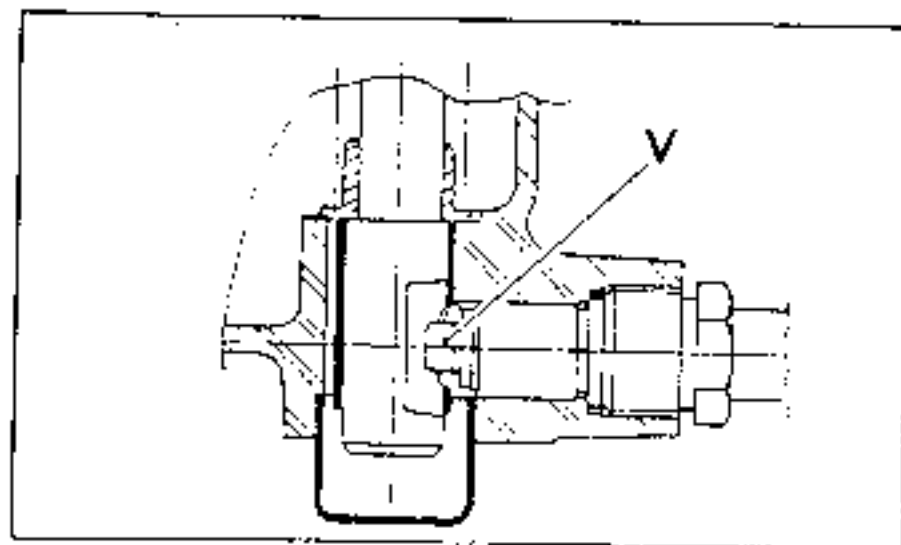
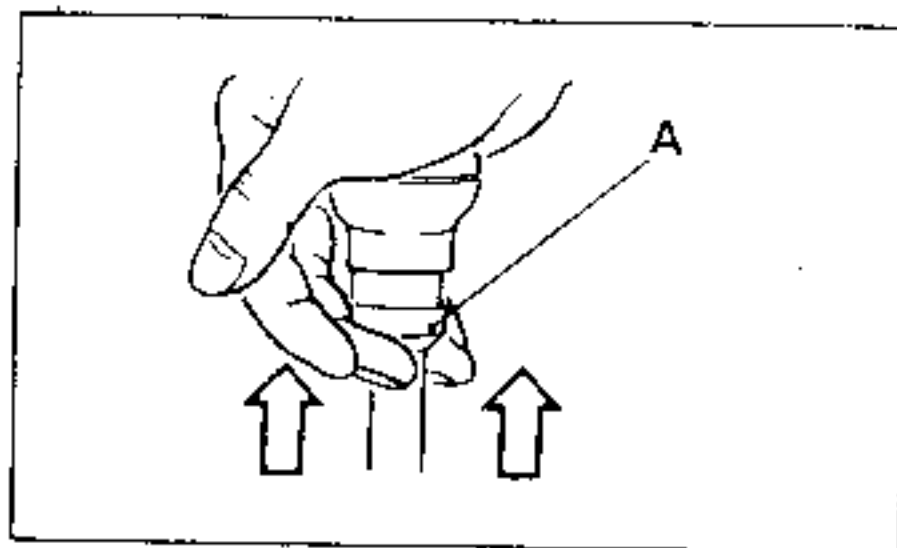

I - Modification to the mounting of the differential lock nut and the type of lip seal

1st type

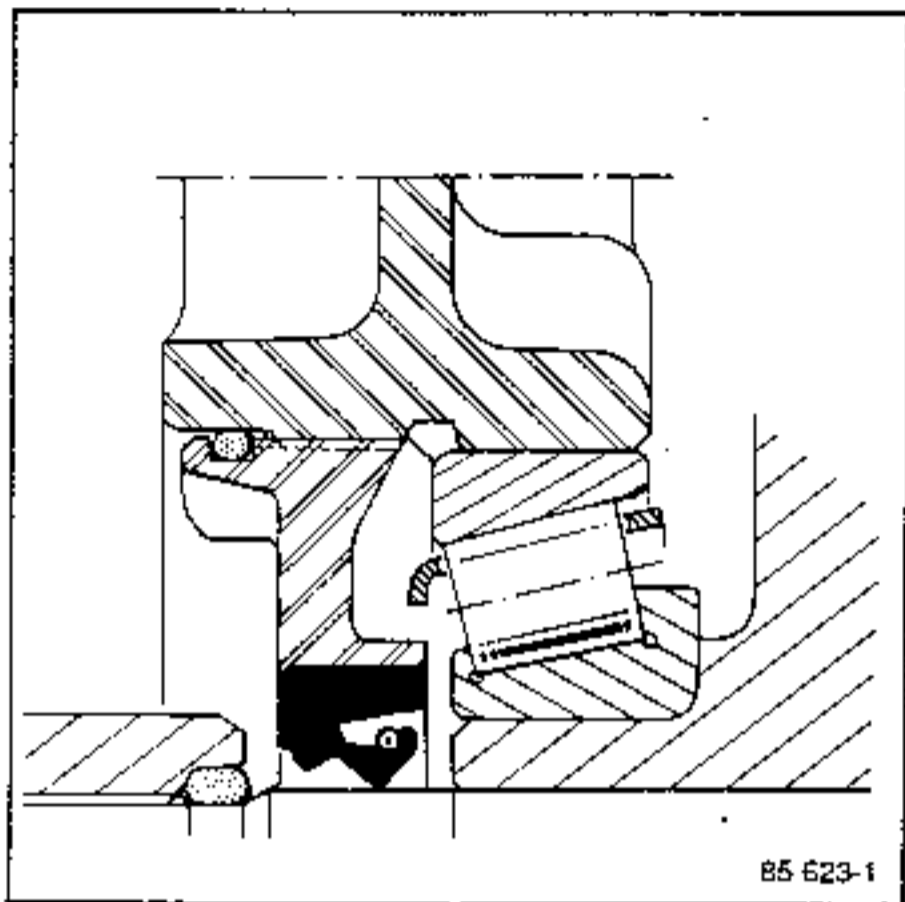

Seal with two lips

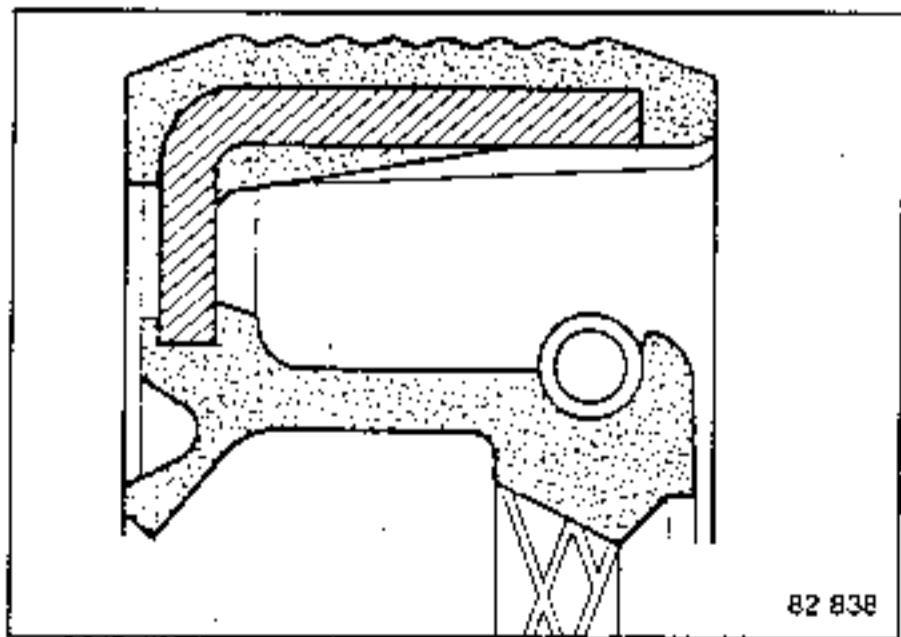

ATTENTION

The Parts Department only supplies the second type of nut equipped with a deflector (C).

When fitting a new nut to a casing which does not have oilway (D), deflector (C), which is fitted quite tightly in the nut, MUST be removed.

2nd type

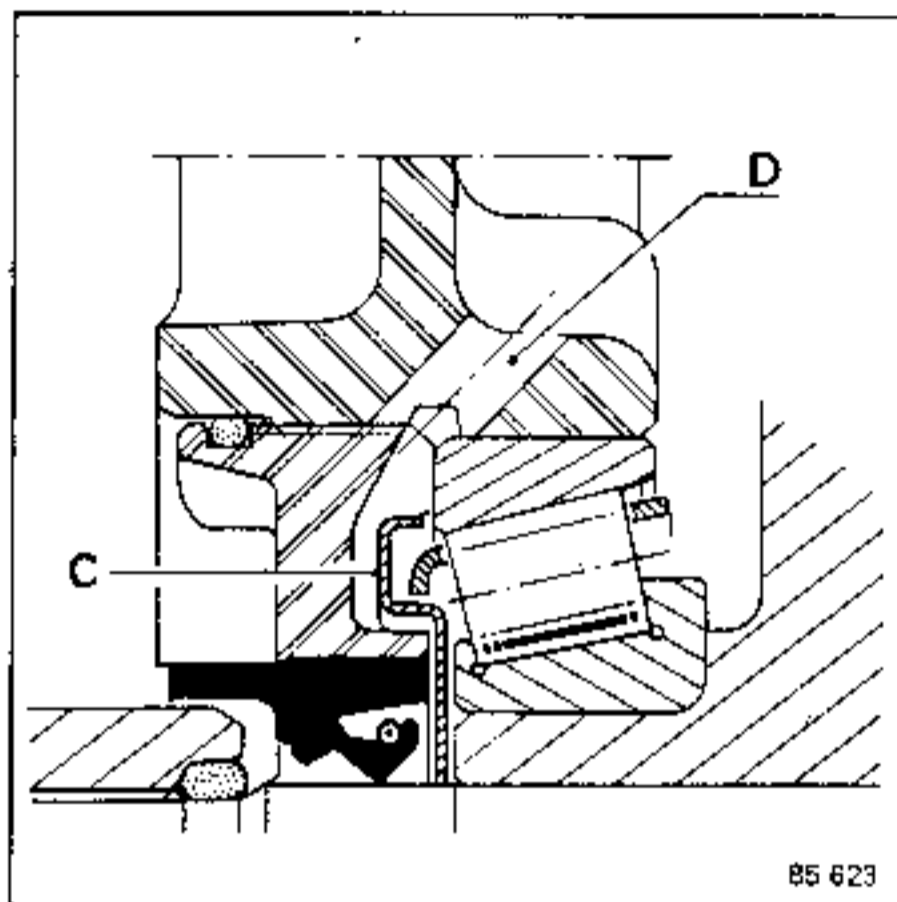

Front bush-type seal

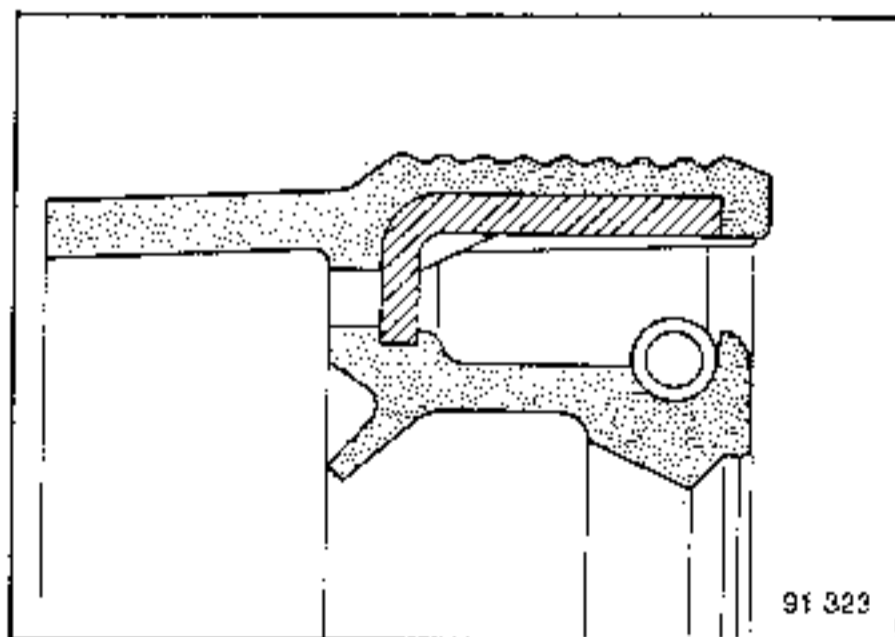

Special point:

Addition of an oil deflector (C) on the differential lock nut mounted on a casing with additional oilway (D).

II - Modification to the direction for fitting the 3rd/4th speed synchro, following movement of the snap ring groove on the secondary shaft

All the parts are identical but dimensions X and Y on the secondary shaft are different.

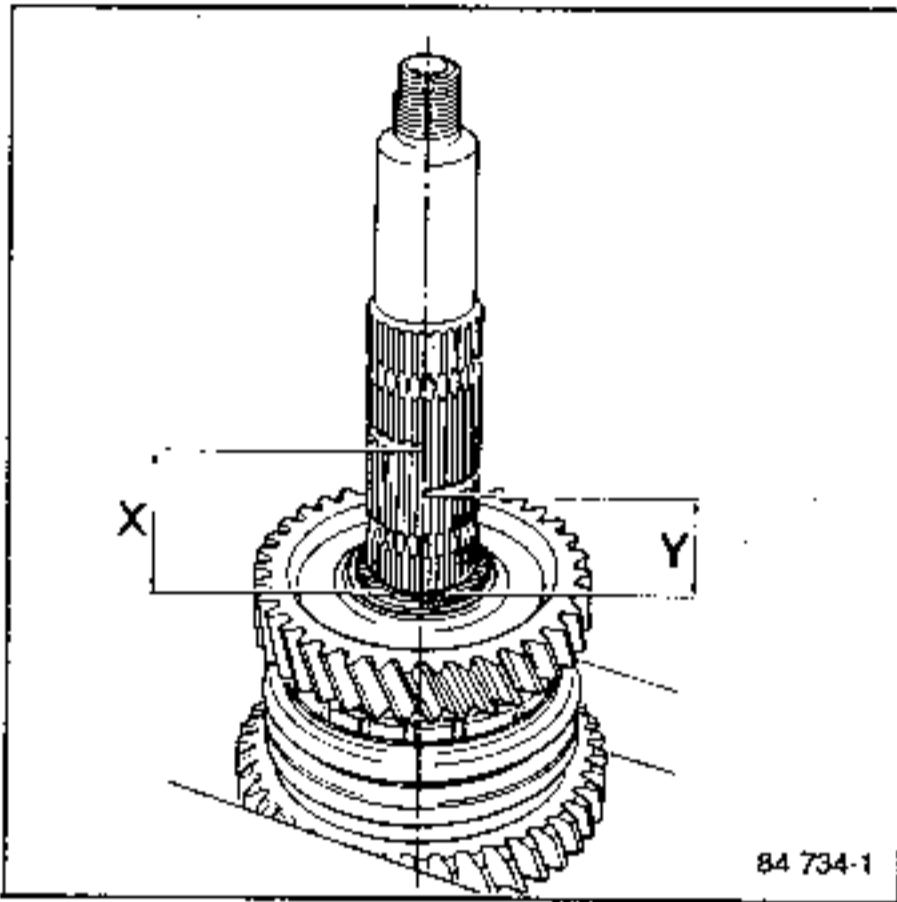

- 1st type: X = 48.5 mm
- 2nd type: Y = 33.5 mm

Make sure the synchro roller springs are fitted the correct way round.

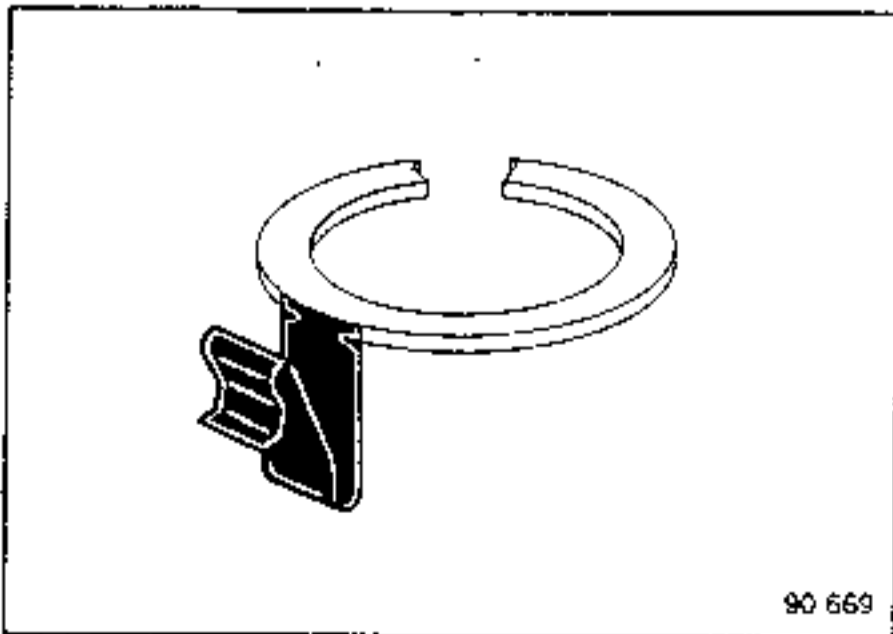

The locking tabs must be fitted so that they are on the snap ring side.

1st type

X = 48.5 mm

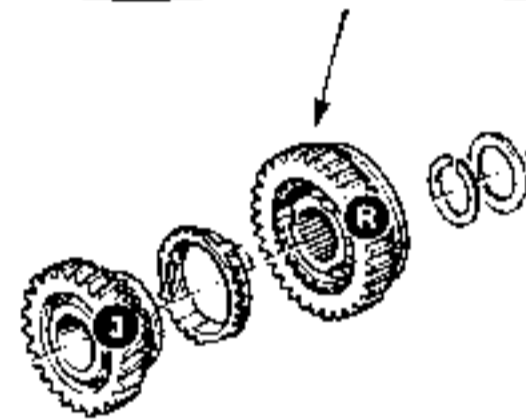
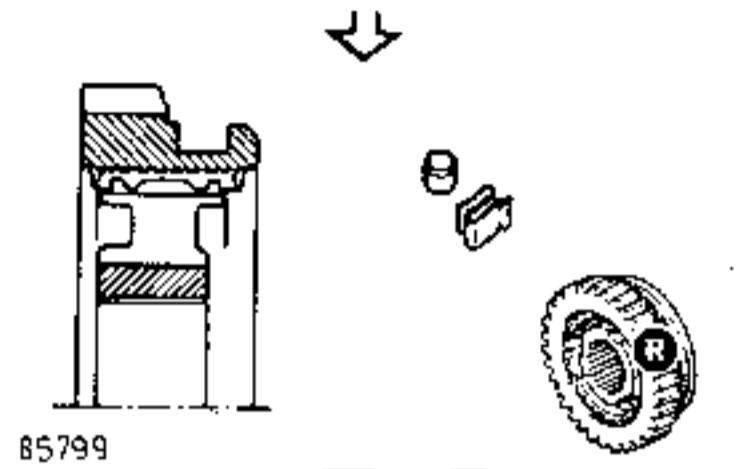

2nd type

Y = 33.5 mm

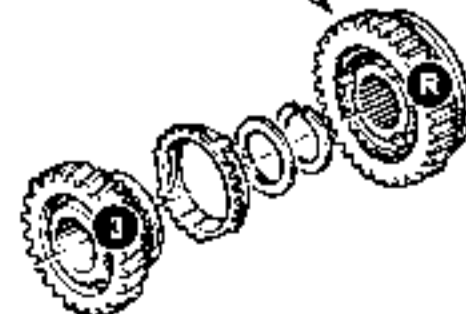
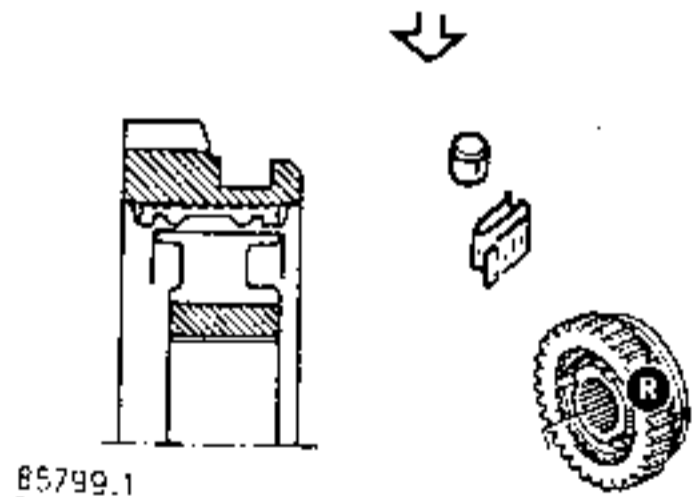

III - Modification to the 5th speed assembly

The primary and secondary shaft splines holding the 5th speed synchro hub and fixed gear have been modified.

1st type
Shaft with straight splines (B).

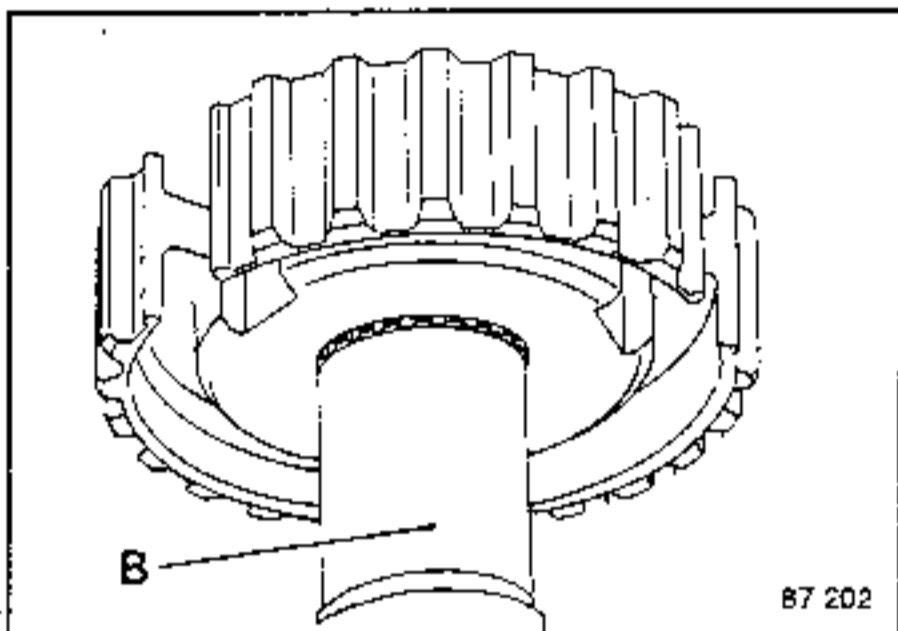

2nd type
Shaft with helical splines (A).

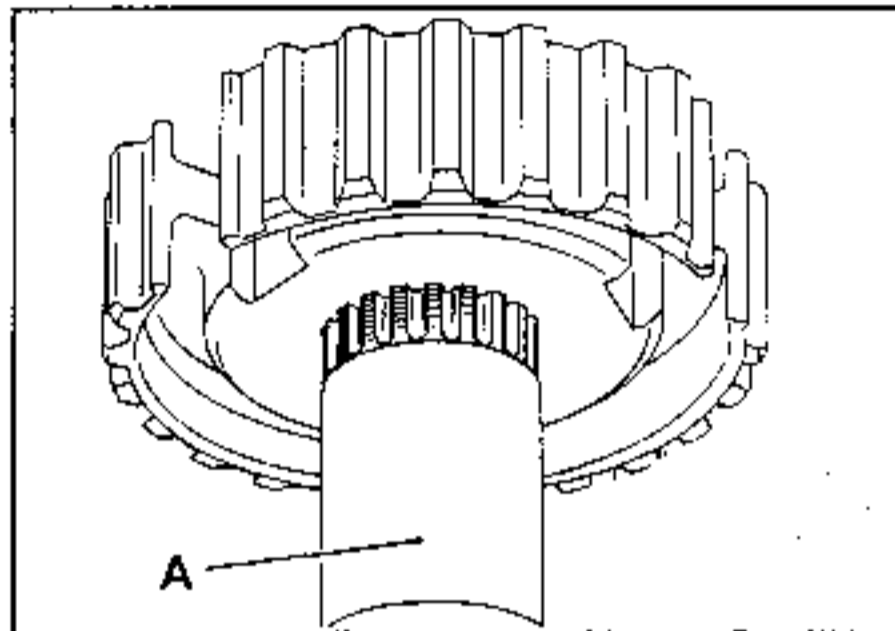

IDENTIFICATION

To identify the different shafts, place the shaft vertically and fit the 5th speed hub (primary shaft) or the 5th speed fixed gear (secondary shaft) on the splines.

The hub or fixed gear engages completely in the splines.

The hub or fixed gear does not engage completely in the splines.

SPECIAL POINT

When reassembling the parts, the synchro hub and fixed gear must be bonded with Loctite SCELBLOC.

In this case the hub or fixed gear are a torque fit, the tightening torque required being between 100 daN and 1500 daN.

- An extractor tool must be used to dismantle these parts.
- When reassembling the parts, they must be coated with Loctite FRENBLOC.

NOTE

If excess Loctite is applied the 5th speed idler gear needle pin may become jammed.

IV - Secondary shaft: enlargement of the snap ring grooves and splined washers

1st type

Snap ring: 1.9 mm
Splined washer: 1.5 mm

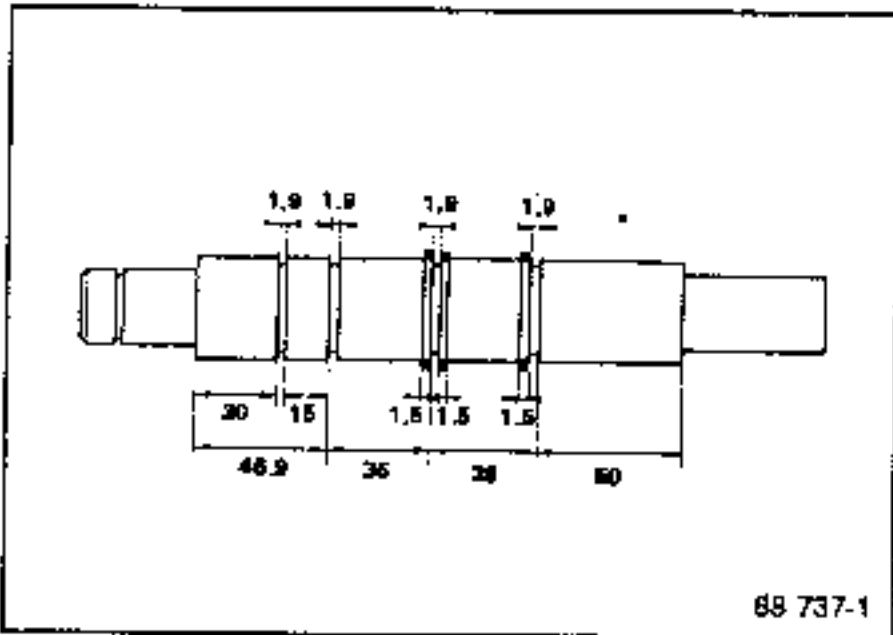

2nd type

Snap ring: 2.8 mm
Splined washer: 2.2 mm

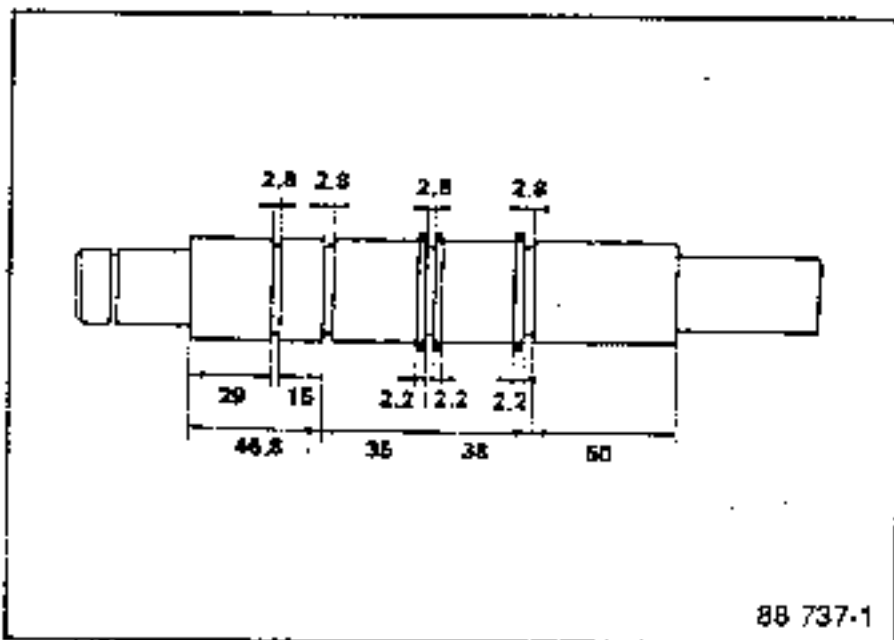

Only the 2nd type of 1st speed idler gear can be used, irrespective of the original type fitted.

There may be an end play of approximately 2mm on a secondary shaft of the 1st type.

V - Strengthening of the first speed idler gear teeth

In order to strengthen the first speed idler gear teeth, the rim width of the gear has been increased by 1.5 mm.

Fitting a larger gear means that the 1st/2nd speed slide gear has had to be modified.

Consequently, a first speed idler gear with an enlarged rim (dimension A = 19 mm) can only be assembled with a modified 1st/2nd slide gear (dimension B = 6.4 mm).

	1st speed drive gear	1st/2nd idler gear
	Dimension A in mm	Dimension B in mm
1st type	≈ 17.5	≈ 7.9
2nd type	≈ 19	≈ 6.4

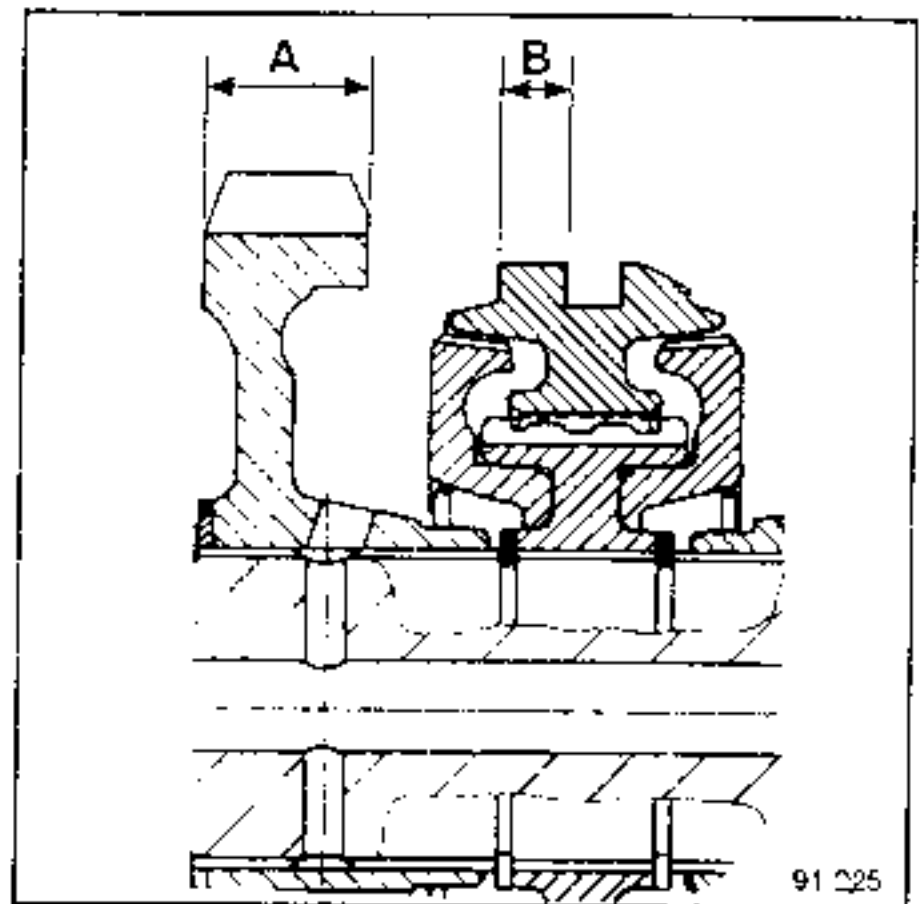

NOTE: The second type of slide gear may be assembled with idler gears of the first or second type.

VI - Lubrication

The gearbox oil grade for TURBO PETROL B29E and B292 VEHICLES has been modified.

In order to provide better resistance to the high temperatures to which the gearboxes on these vehicles are subject, the manual gearboxes must only be lubricated with the high temperature oil recently approved by Renault:

TRANSELF TRX 80 W

VII - Changing the type of spring on the 3rd/4th speed synchro roller (BORG-WARNER)

The "Z"-shaped springs used until now have been replaced by "heart-shaped" springs.

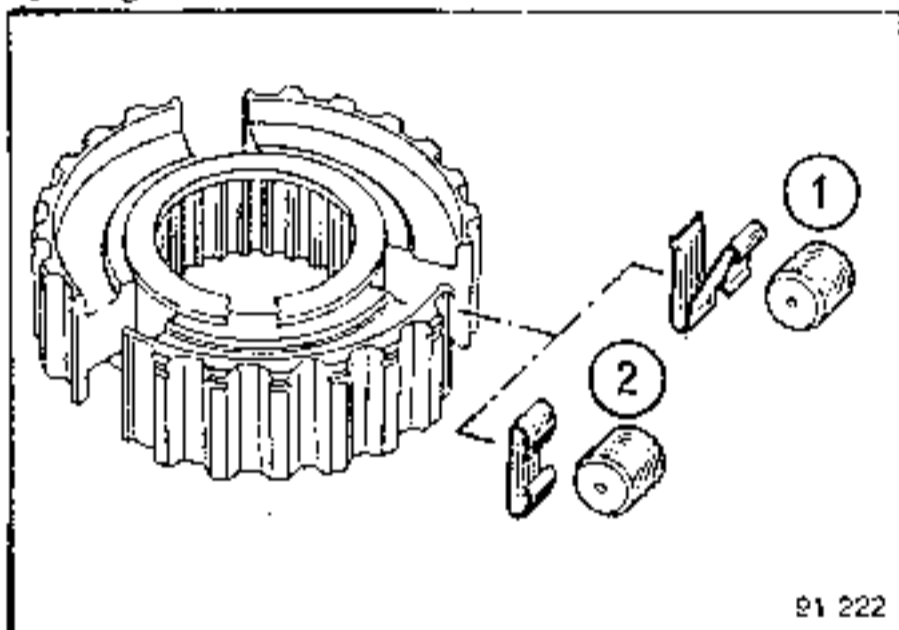

- 1 - 1st type
- 2 - 2nd type

In order that heart shaped springs can be fitted, the inlet chamfer for the bevel shoulder under the 3rd and 4th speed idler gear synchros has been modified.

Consequently, the heart-shaped springs can only be used with modified idler gears.

MECHANISM CASINGS

On the lefthand casing:

The reverse gear intermediate drive gear shaft bearings have been strengthened.

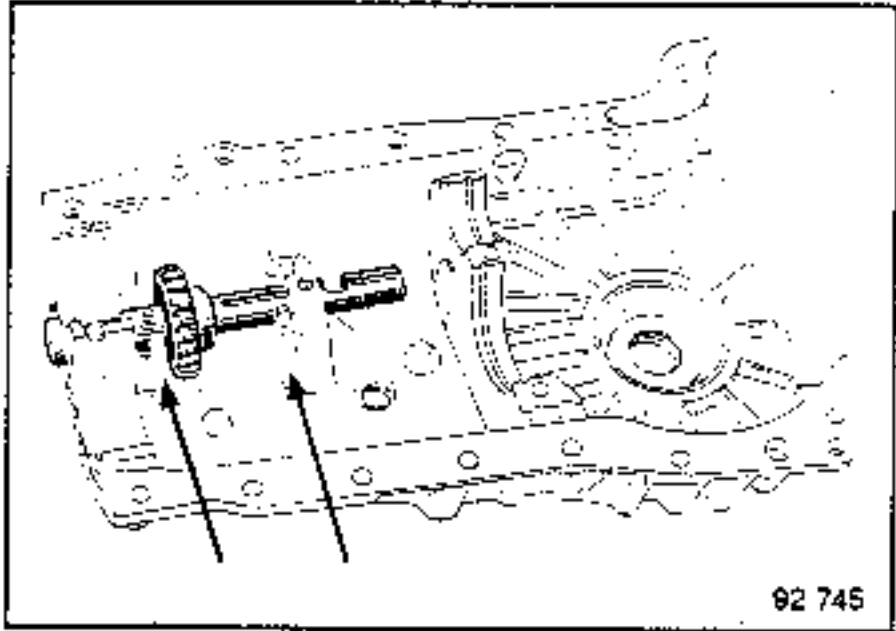

On the righthand casing:

A permanent magnet (of the type fitted to JB gearboxes) is secured by a bar and an unmagnetized drain plug.

NG3: 088 - 089 - 090

- New "small module" teeth for the 3rd, 4th and 5th speed gears.
- Modified primary shaft with a set of taper roller bearings 2 instead of a bearing with a dual row of balls on the rear bearing journal.

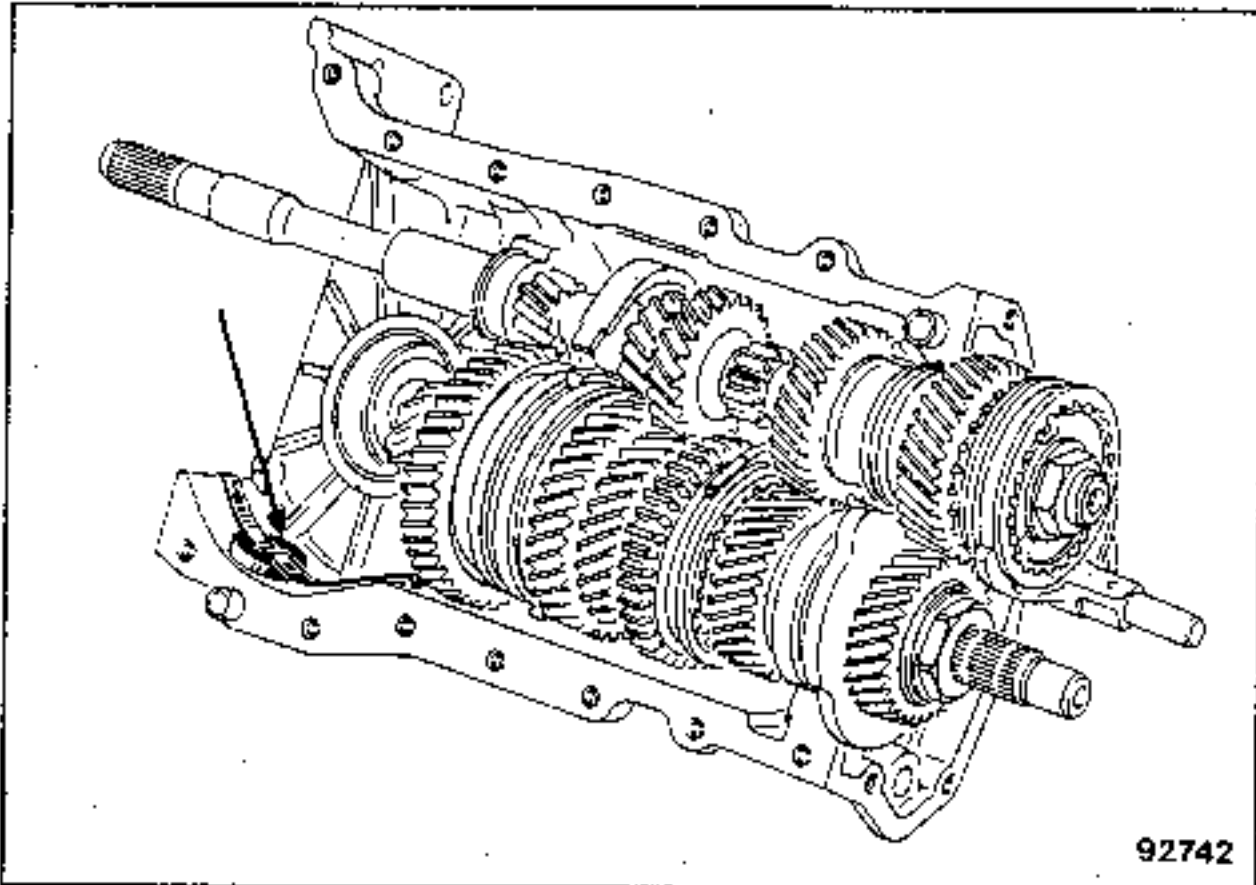
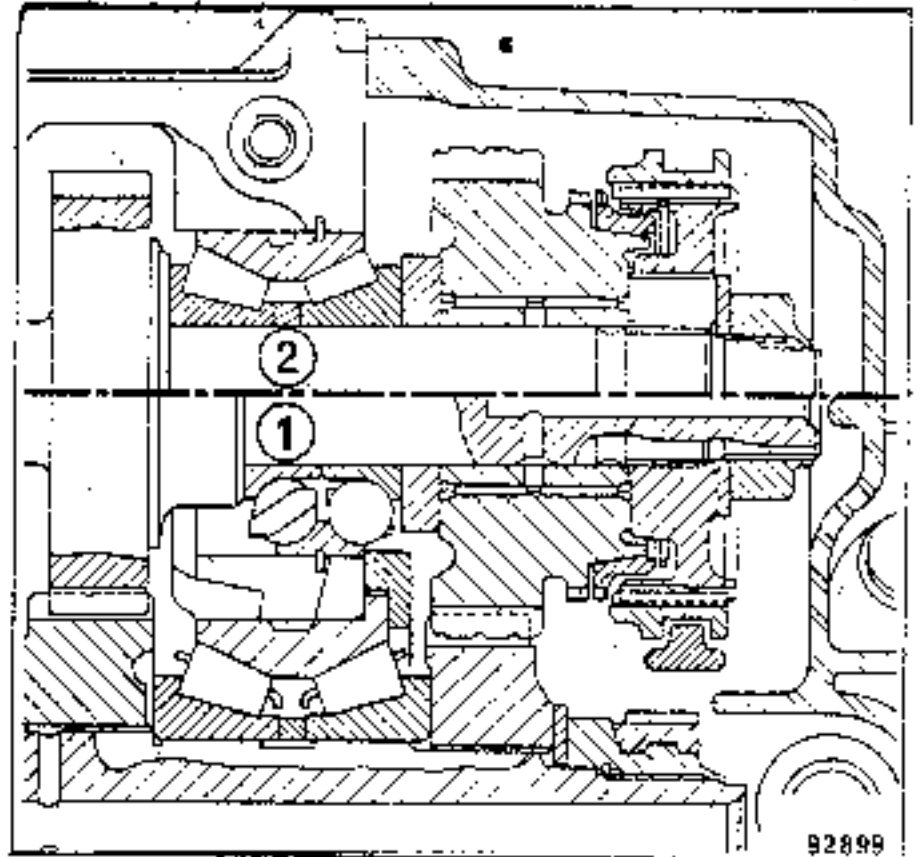

Description	Pack size	Parts no.	To be used for:
No. 20 grease	1 g sachet	77 01 032 832	Sun wheel splines Shaft splines Fork pivot Release bearing guide Fork pads } Clutch
Loctite "518"	24 ml syringe	77 01 421 162	Housing assembly faces
CAF 4/60 THIXO	100 g tube	77 01 404 452	Screwed plugs and switches Locking ball plugs Ends of spring pins on drive-shafts
Loctite FRENBLOC (Locking and sealing resin)	24 cc bottle	77 01 394 071	Primary & secondary shaft nuts 5th speed fixed gear and hub Engagement actuator
Loctite SCELBLOC (Locking and sealing resin)	24 cc bottle	77 01 394 072	5th speed fixed gear 5th speed hub } (depending on type of assembly)
Perfect-Seal "LOWAC" (Fluid coating, seals)	100 g tube	77 01 417 404	Paper gaskets on rear and step down covers except NG7
Gearbox oil			Immersion of all parts

Parts to be replaced systematically

when they have been removed:

- all paper gaskets;
- all lip-type oil seals;
- all differential housing bolts;
- all rollpins;
- reverse lever bolt;
- all O-ring seals;
- the thrust pad guide tube;
- all snap rings;
- the primary and secondary shaft nuts;
- the speedometer drive gear;
- the output flange bolt (NG7);
- the spring washer on the 5th speed fixed gear.

GRATING WHEN ONE GEAR IS ENGAGED.
(after first checking the clutch)

KEY :

Check

Operation
to be
carried out

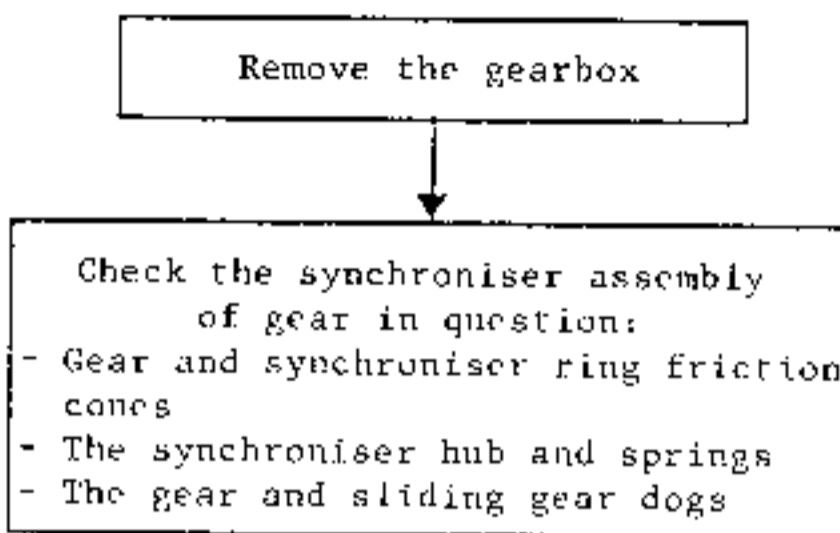

IMPOSSIBLE TO ENGAGE GEARS
(after first checking the clutch)

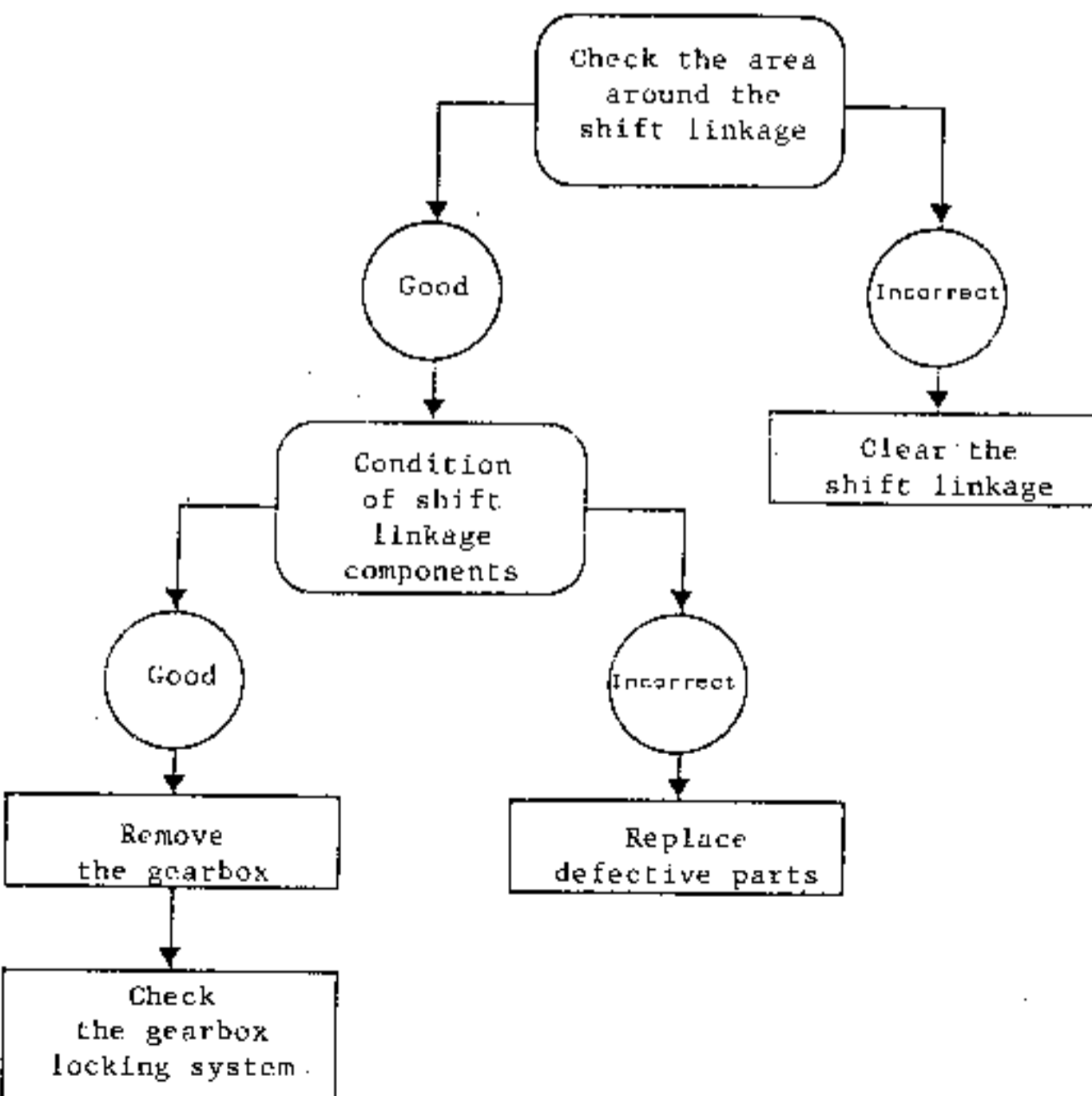

KEY:

Check

Operations
to be
carried out

SLIPPING OUT OF GEAR

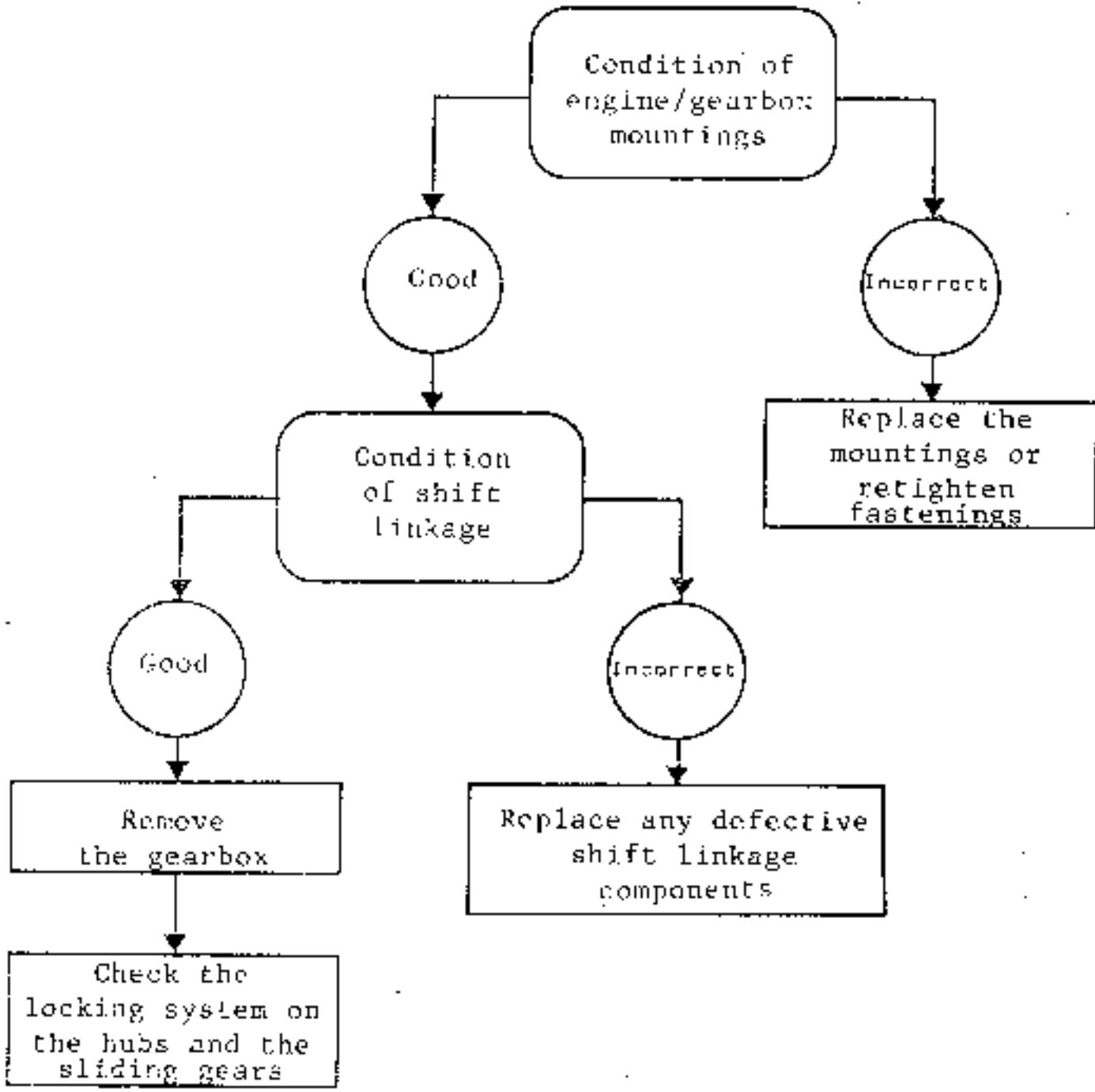

JAMMING IN ONE GEAR

KEY:

Check

Operations
to be
carried out

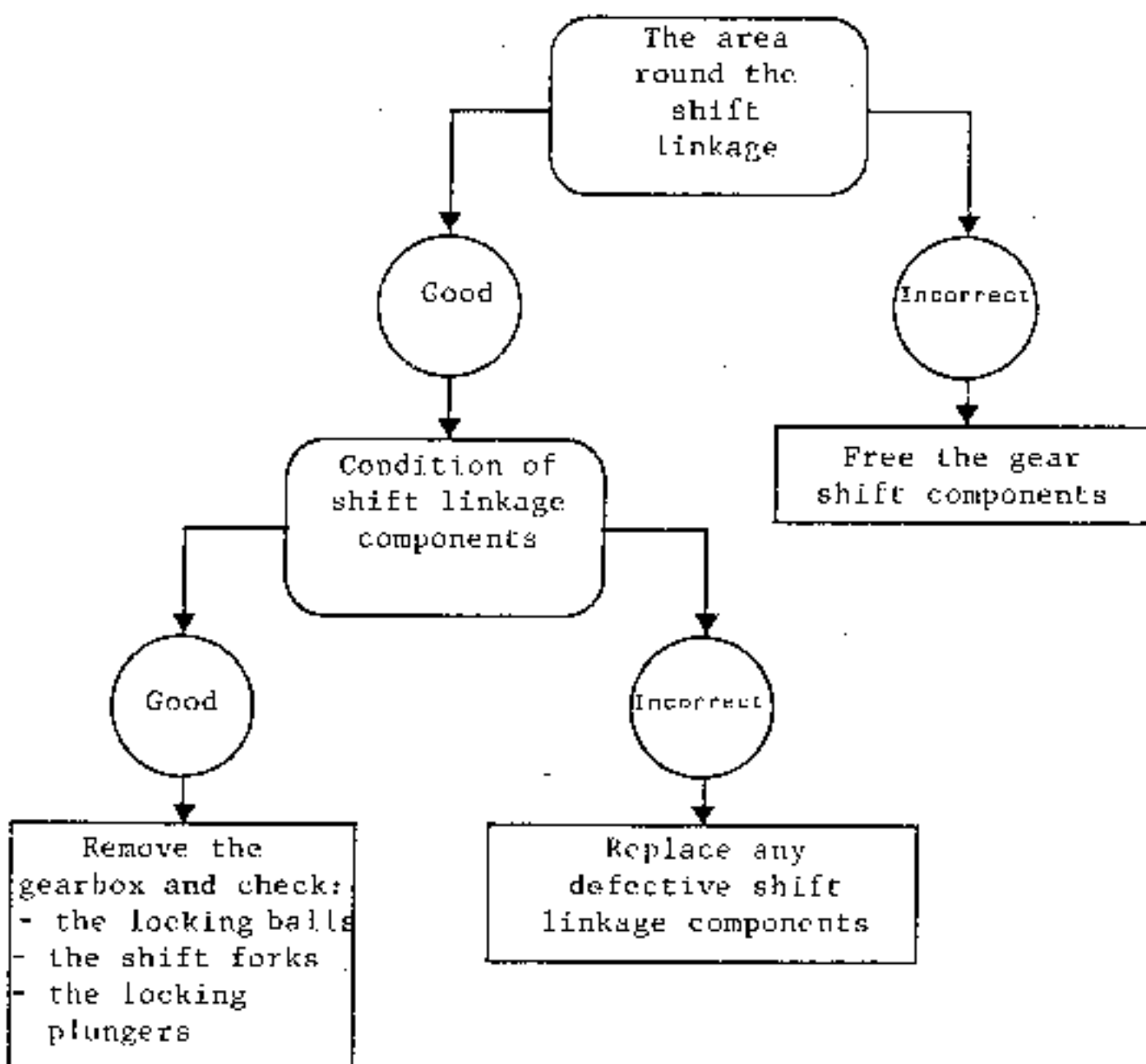



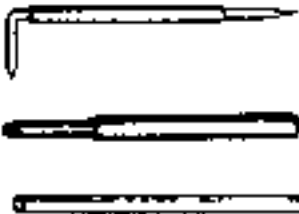





Illustration	Methods Reference	Part no.	Description
	B. VI. 022-01	00 01 216 401	Extractor without shell
68 994			
	B. VI. 28-01	00 01 227 301	Extractor with interchangeable claws
71 625			
	B. VI. 31-01	00 01 259 401	Set of 3 punches for fitting 5 mm ϕ spring pins
68 997-1			
	B. VI. 39	00 01 322 500	Drift for 4 and 10 mm rollpins
69 001			
	B. VI. 41	00 01 234 800	Shell with 23.5 mm opening for bearing extractor B.VI.22-01
69 005			
	B. VI. 47	00 01 331 100	Shell with 28 mm opening for bearing extractor B.VI.22-01
69 006			
	B. VI. 48	00 01 330 300	Set of 2 jaws with big tips (for use with B.VI.28-01)
69 006			
	B. VI. 204-01	00 00 020 401	32 mm wrench for secondary shaft nut
69 009			

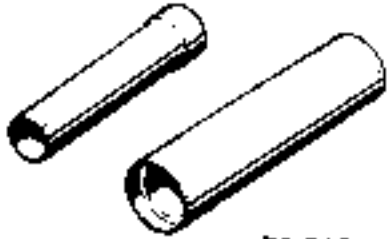

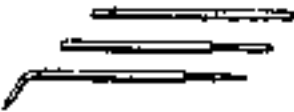
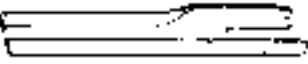



Illustration	Methods Reference	Part no.	Description
 <p>72 612</p>	B. Vi. 488	00 00 048 800	Clutch shaft oil seal inserting and protecting tool
 <p>72 612</p>	B. Vi. 526	00 00 052 600	Clutch shaft oil seal inserting and protecting tool
 <p>77 743</p>	B. Vi. 606	00 00 060 600	Set of punches for replacing 6 mm dia. spring pins
 <p>79 406</p>	B. Vi. 747	00 00 074 700	Fork for removing and refitting the selector spring
 <p>87 198</p>	B. Vi. 807-01	00 00 080 701	Differential ring nut wrench New type of sealing
 <p>81 786</p>	B. Vi. 813	00 00 081 300	Differential ring nut oil seal protector When passing over splines
 <p>84 912</p>	B. Vi. 883	00 00 088 300	Differential collar press tool
 <p>84 817</p>	B. Vi. 905-02	00 00 090 502	Tools for replacing the speedometer drive shaft.

Illustration	Methods Reference	Part no.	Description
--------------	----------------------	----------	-------------



87 216

B. VI. 1003 00 00 100 300

Extractor for removing the 5th speed hub from the primary shaft

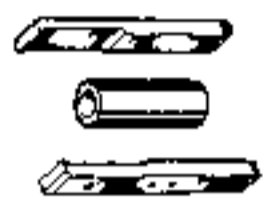

87 579

B. VI. 1007 00 00 100 700

Set of 2 claws and a protective end fitting for gear wheel extractor (for use with B.VI.28-01)

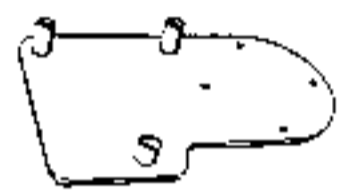

77 749

B. VI. 1016 00 00 101 600

Gearbox support plate



92 914

B. VI. 1154 00 00 115 400

Differential oil seal fitting tool

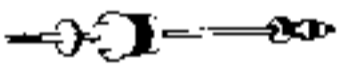

84 328

Emb. 880 00 00 088 000

Clutch fork pin extractor



69 306-1

Rou. 015-01 00 01 331 601

Protective end cup with 16 mm dia. bore for shaft

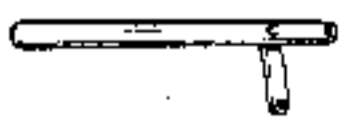

7 672

Rou. 604-01 00 00 060 401

Hub locking tool

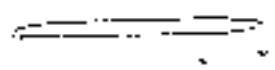

69 376

Car. 041 00 01 310 400

Extractor for 6 mm dia. door hinge pins

SEPARATING THE CASINGS

The parts must be dismantled and handled on a bench with an anti-impact covering (thick rubber or plastic)

Secure the gearbox to stand B.Vi. 1016.

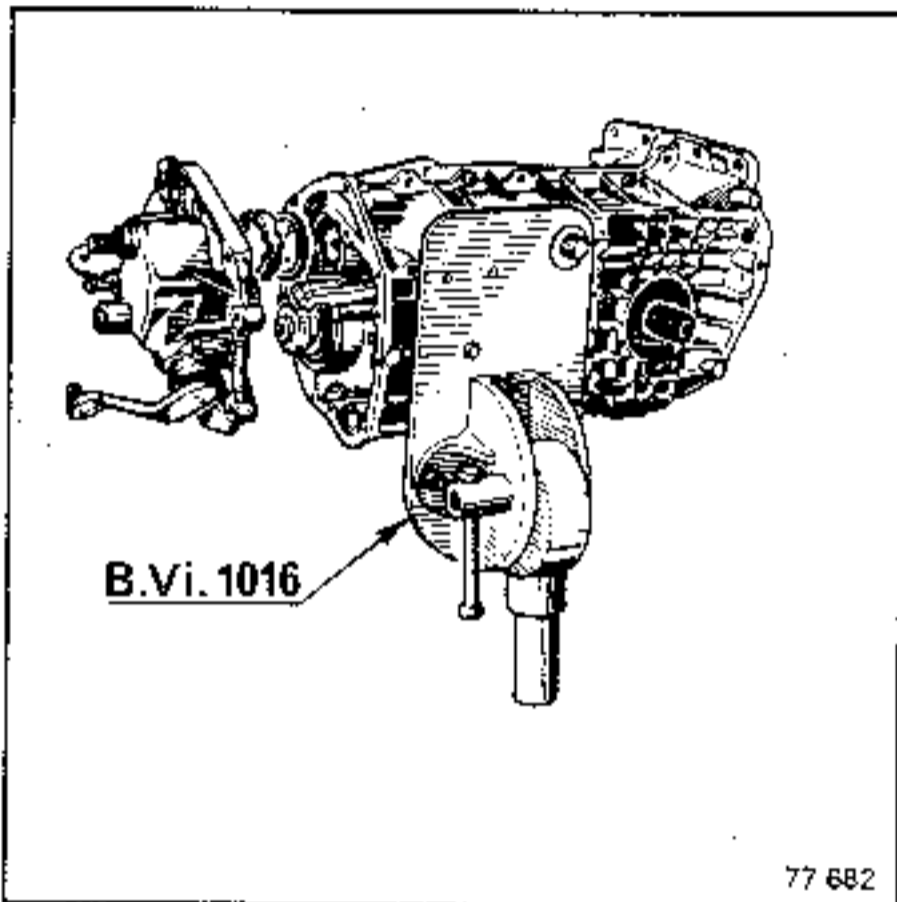

Make a mark on the casings and differential lock nuts.

Remove the lock plates.

Using tool B.Vi.807-01, slacken one nut by 1/6 of a turn so as to cancel the differential bearing pre-load.

Remove the O-ring seals from the sunwheels.

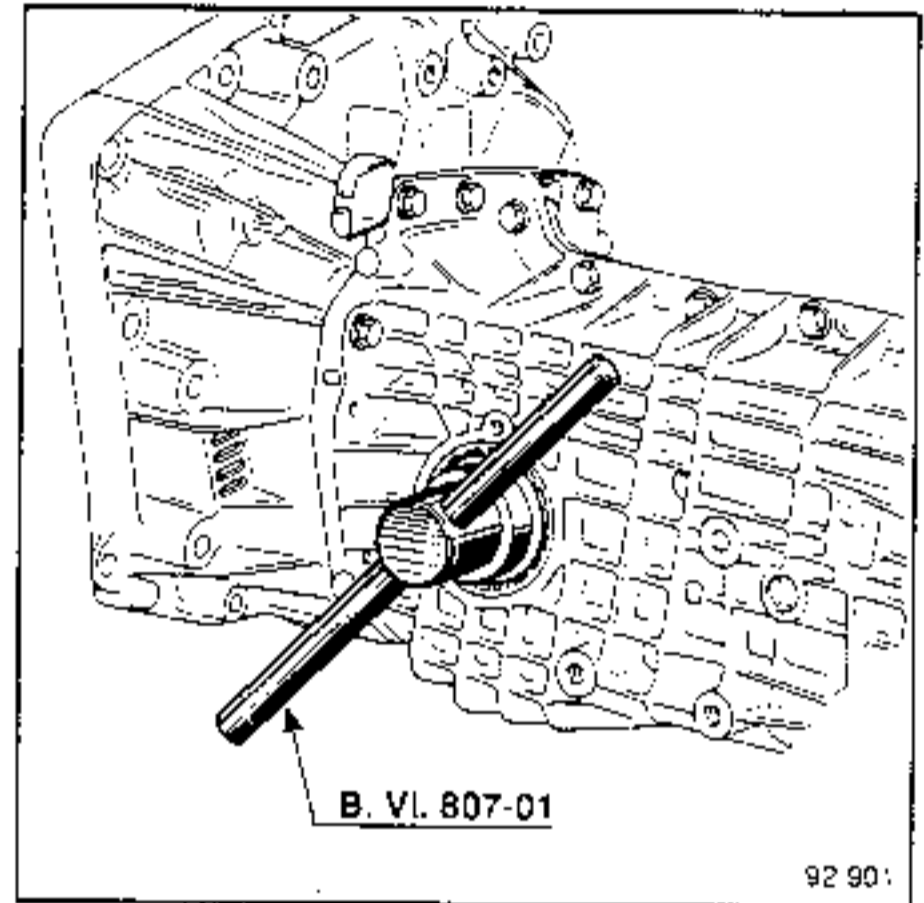

Remove the thrust pad.

Disengage the fork from the pivot and remove it.

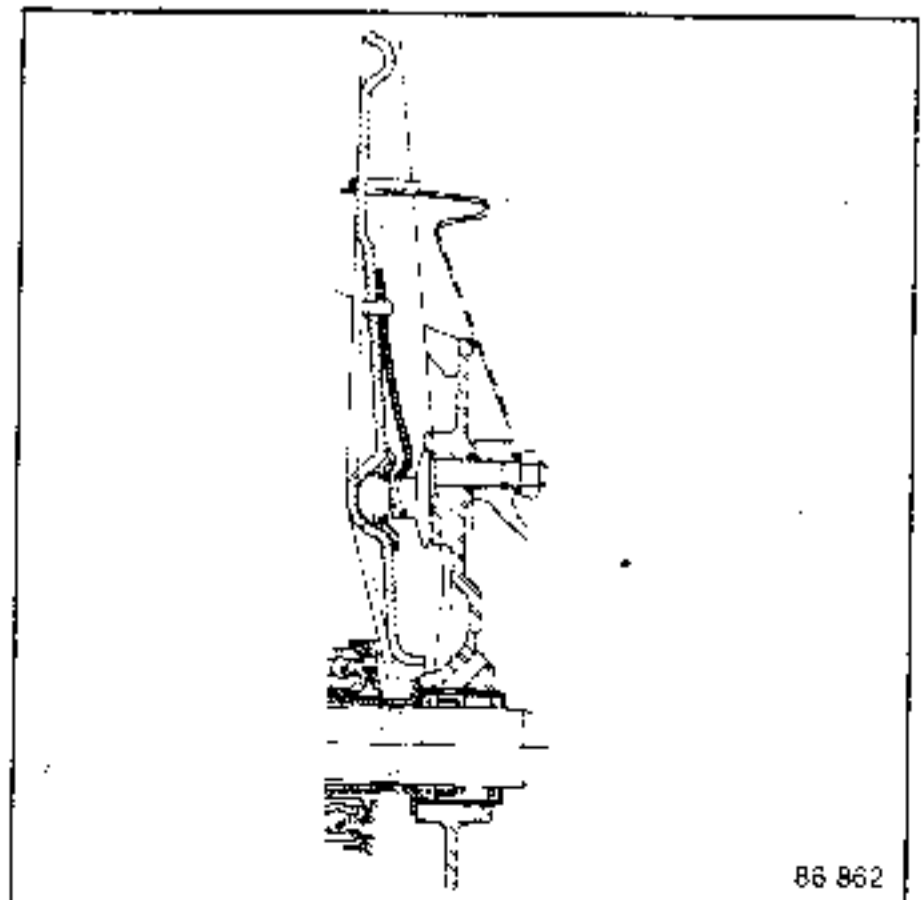

SEPARATING THE CASINGS

Remove:

- the pivot;
- the clutch casing mounting bolts;
- the clutch casing;

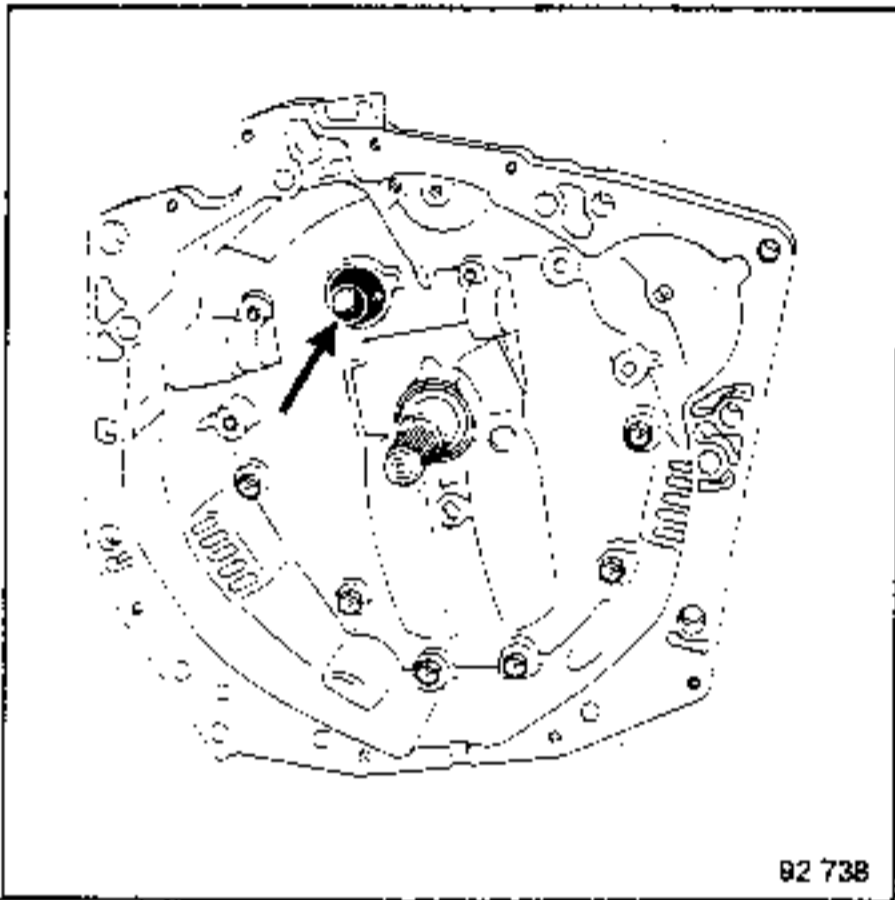

- the 5th speed locking ball (B) - NG1 - NG3 - NG9.

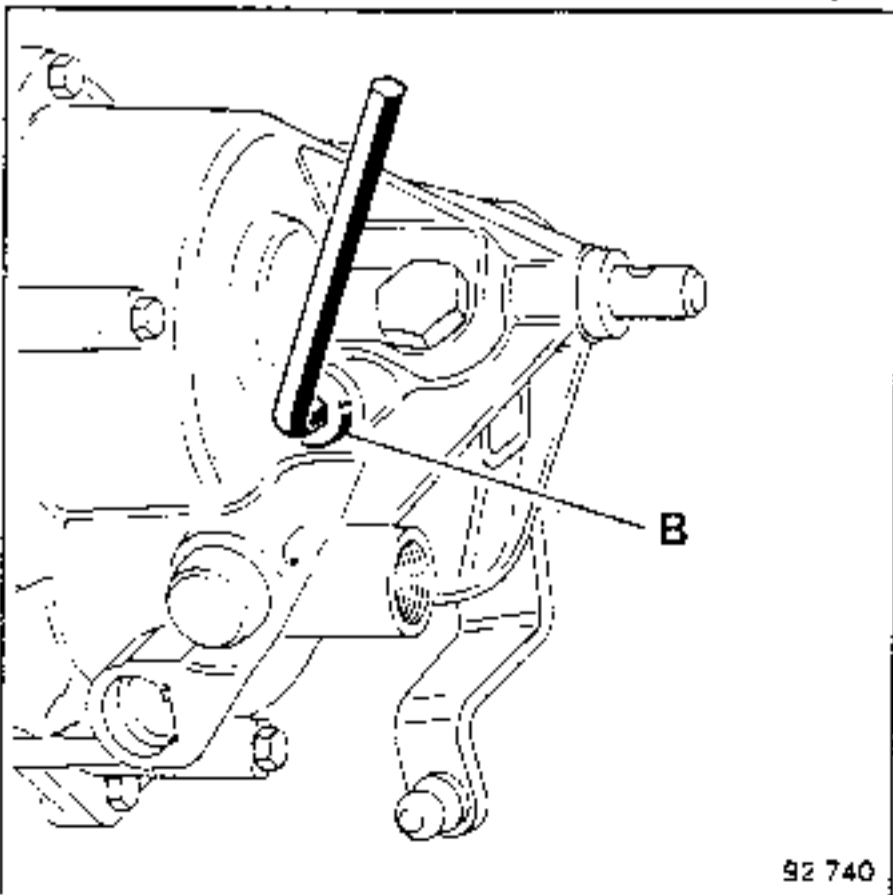

NG7:

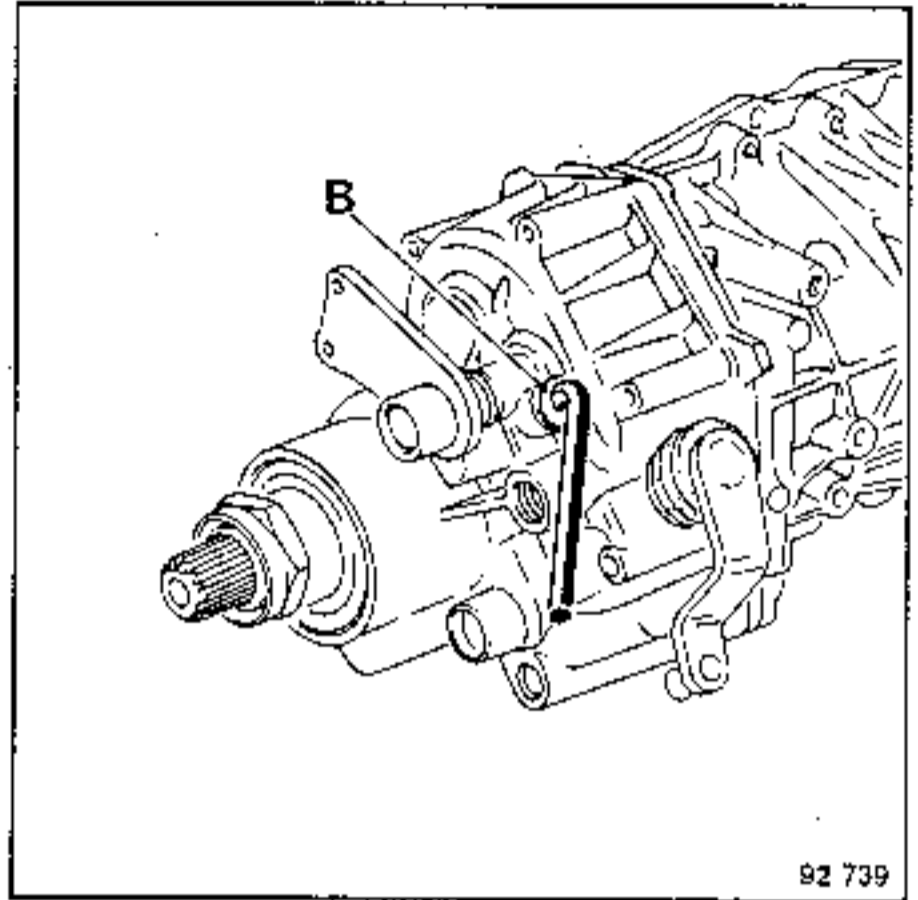

Engage 4th gear so that the 5th speed shaft (A) locks since there is a risk of locking ball (C) falling into the gearbox.

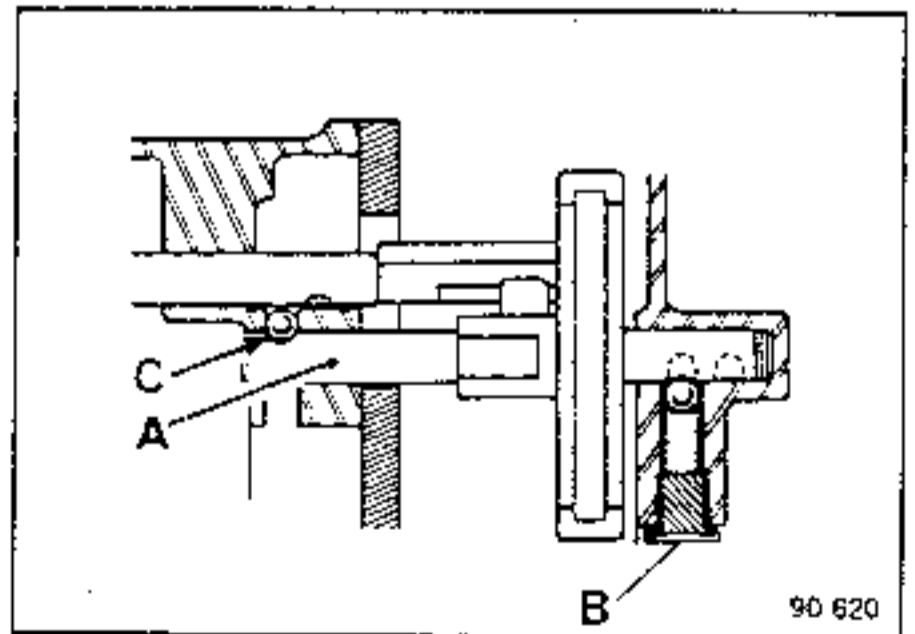

Remove the rear casing.

Engage neutral once again.

SEPARATING THE CASINGS

NG5: Special point: Gearbox in neutral

Remove:

- plug (B), the 5th speed spring and locking ball;
- plug (C), the plunger, and locking ball between the 5th speed shaft and 3rd/4th speed shaft.

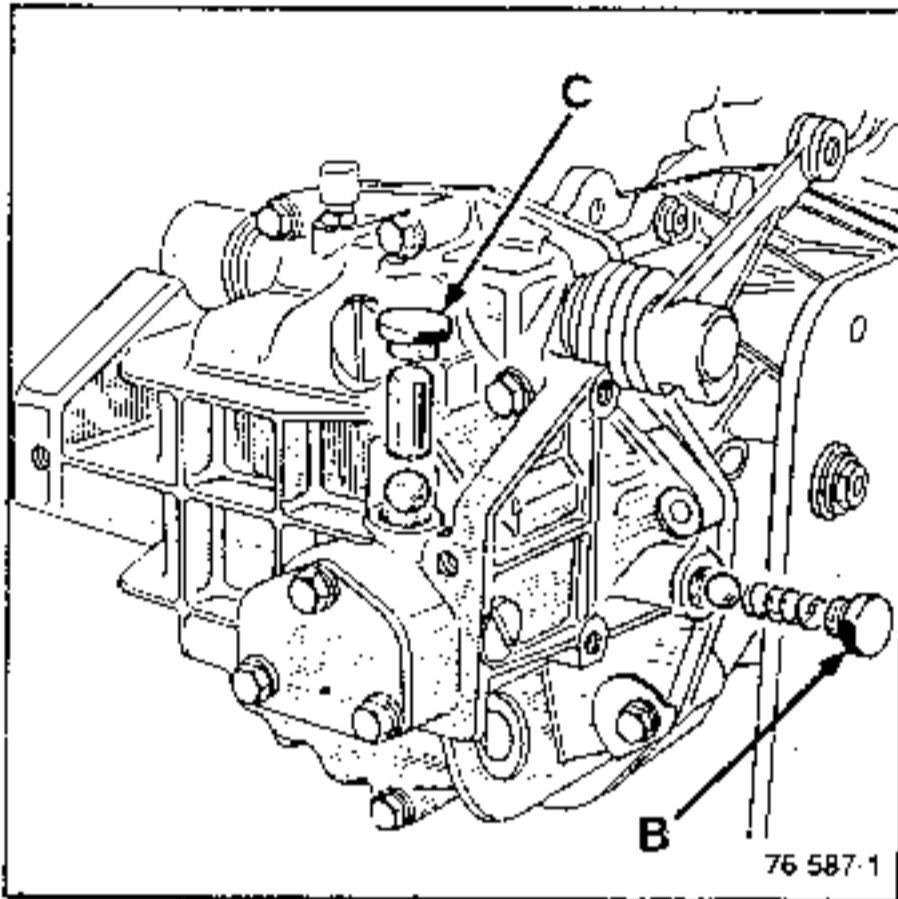

Remove the rear casing.
Recover the 5th speed fork ball.
Engage two gears (5th and 3rd or 4th).
Break the seal on and unfasten parts 45 and 23 (using wrench B.V.204-01).

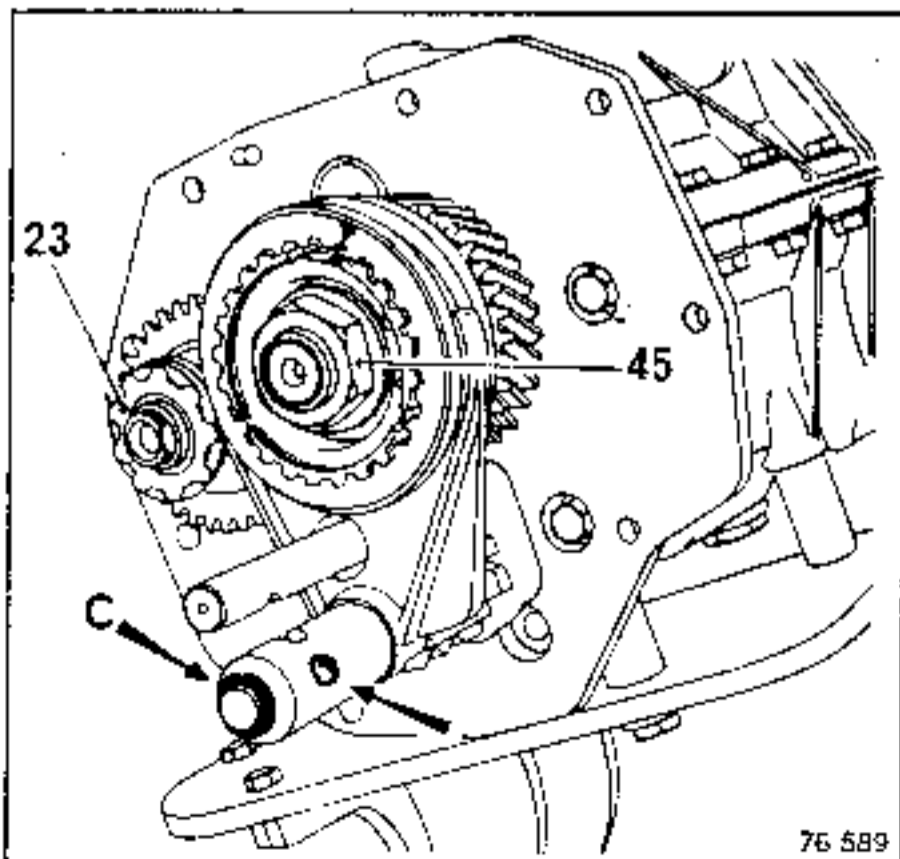

Remove circlip (C) from the end of the reverse gear shaft.

Remove:

- the 5th speed synchro assembly (hub-slide gear and shaft fork) using tool B.VI.1003;

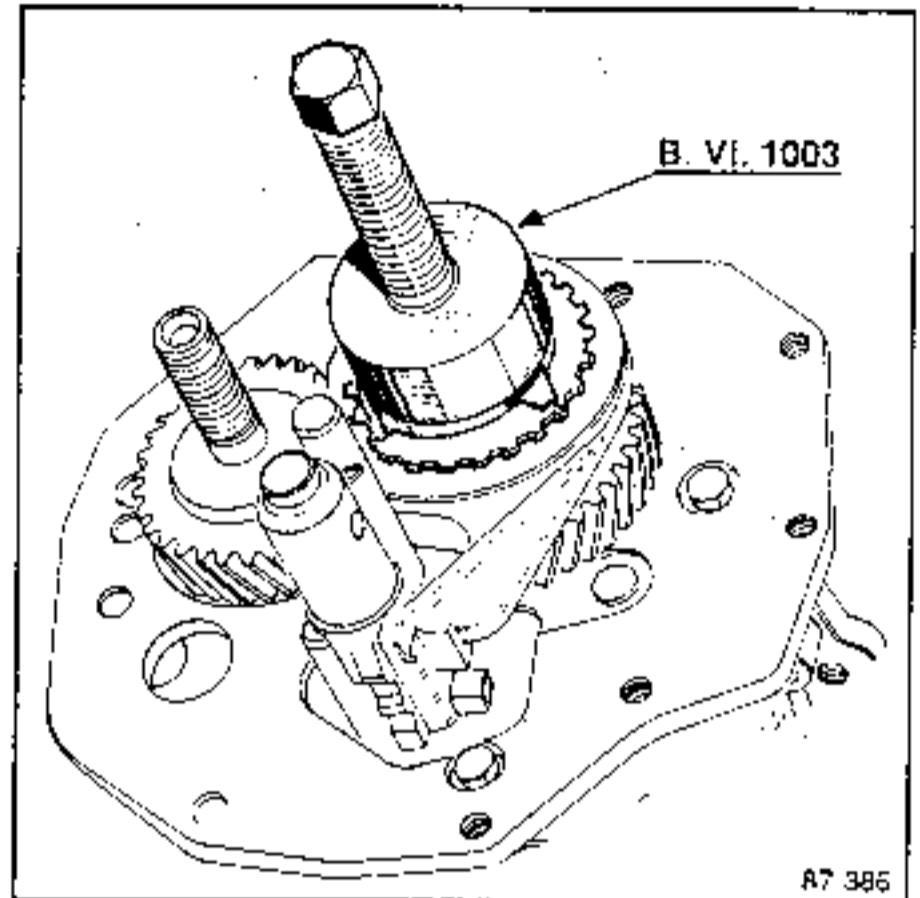

- the 5th speed fixed gear using tool B.VI.28-01 fitted with jaws B.VI.1007;

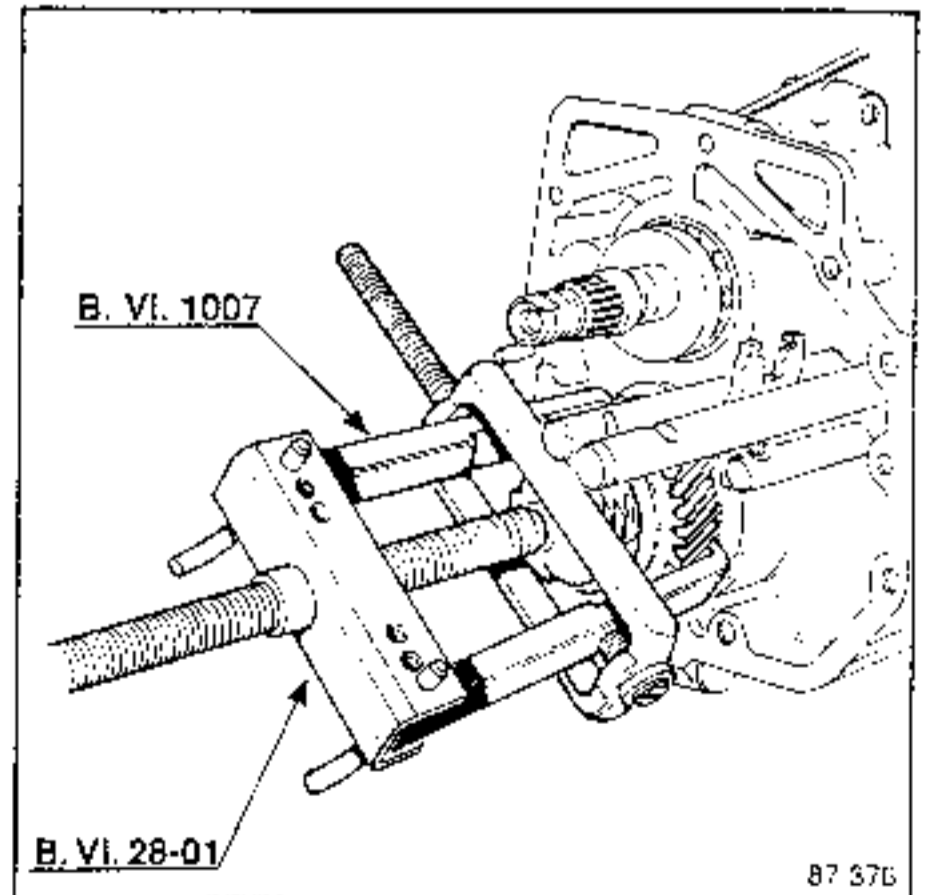

- the spacer plate and its seal.

SEPARATING THE CASINGS

All types:

Separate the casings.

Remove:

- the differential;

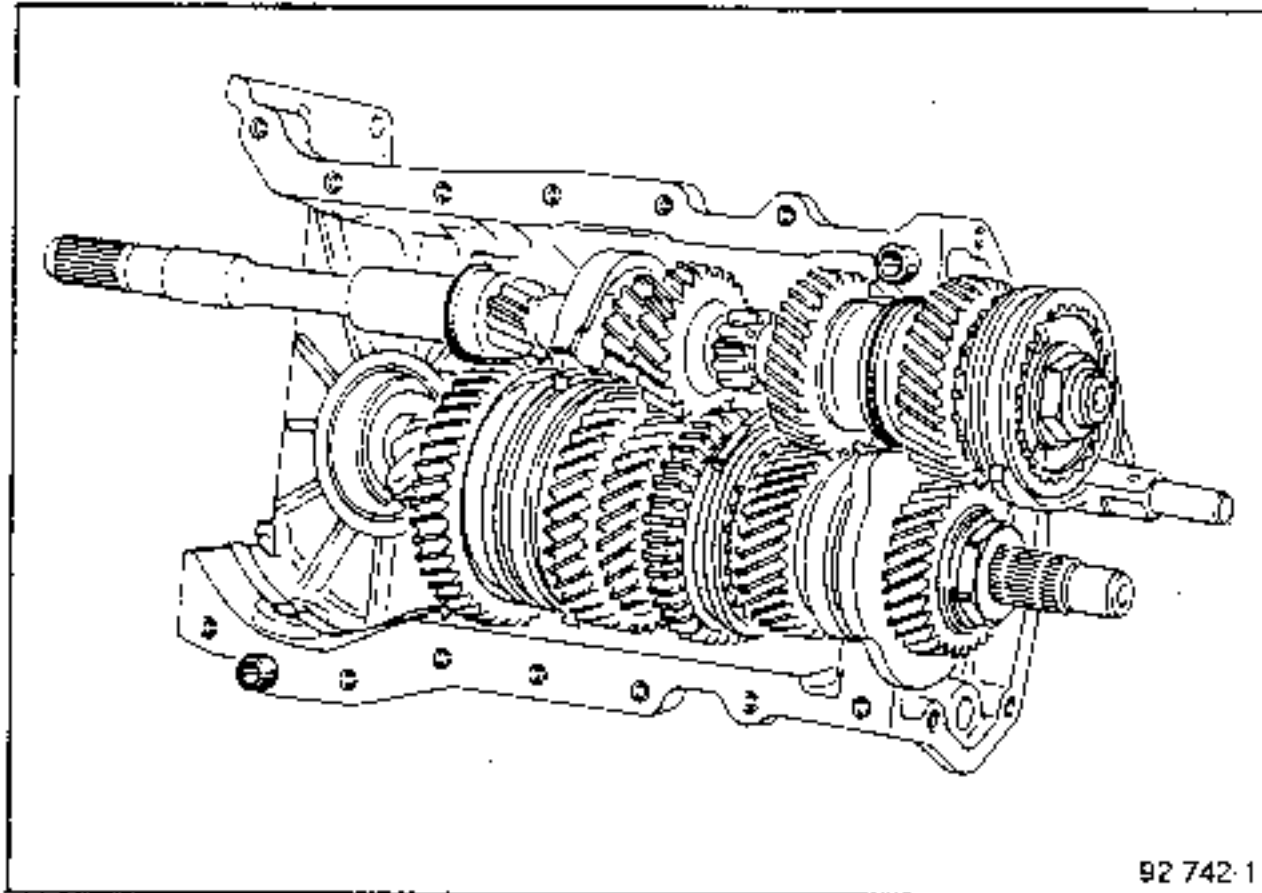

- the secondary shaft gear train;

- the primary shaft, after first moving the reverse gear lever (arrow in diagram).

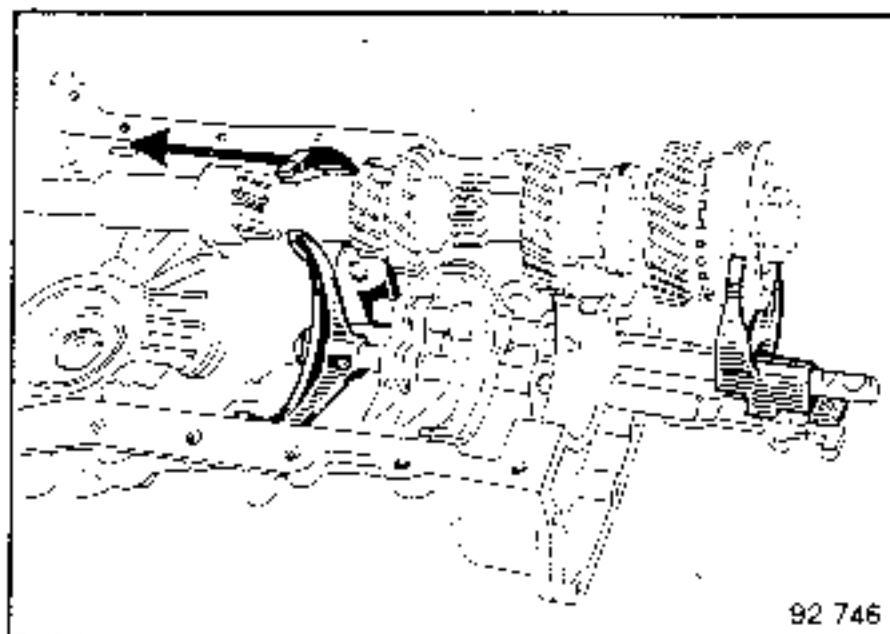

Cleaning the half-casings

Never scratch the bearing faces and seatings with metal tools to clean them. They must always be cleaned with a cloth soaked in a cleaning product and dried off with clean compressed air.

If necessary, remove any burrs.

PRIMARY SHAFT

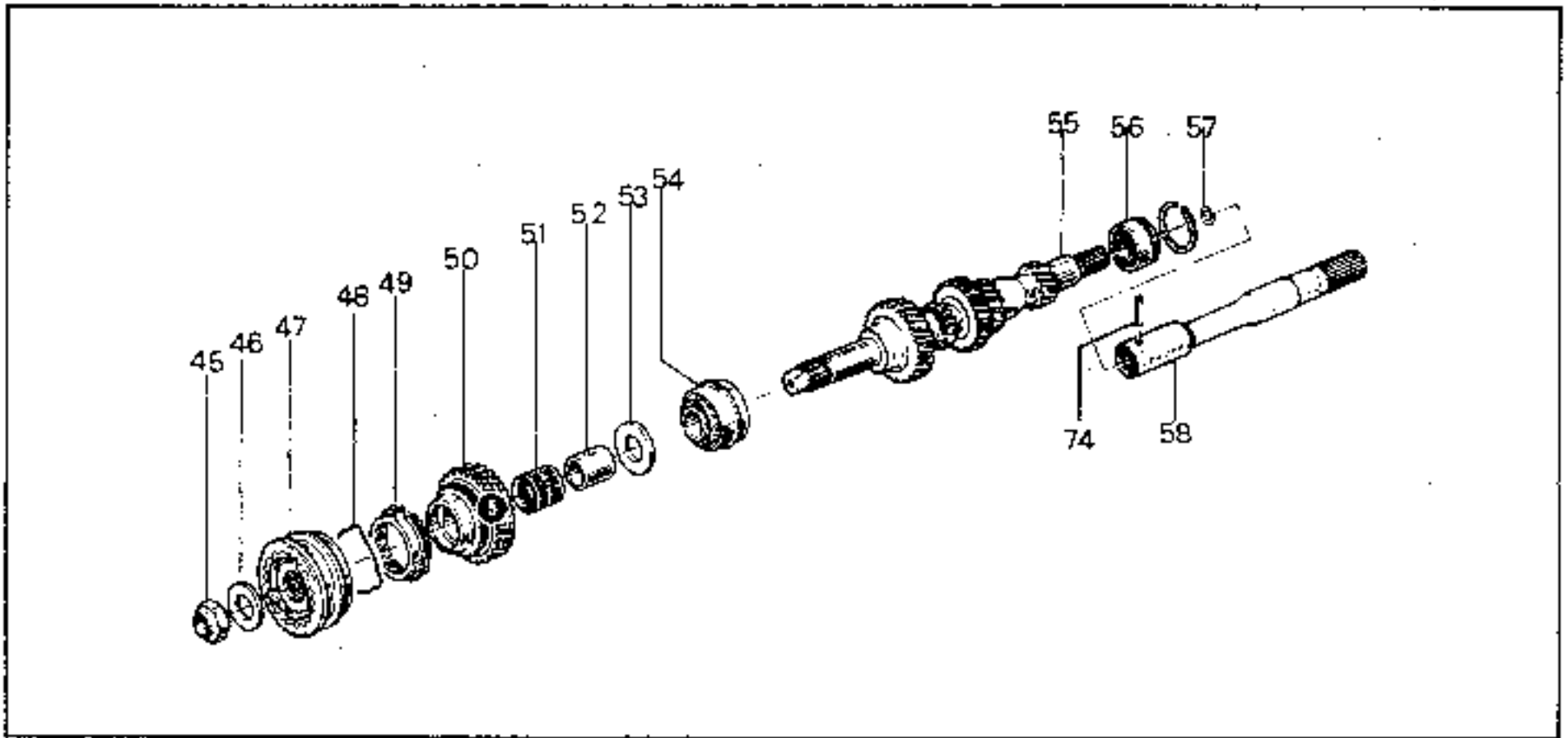

Dismantling - Reassembling

This operation is performed after the casings have been separated.

TIGHTENING TORQUE (in daNm)	
Primary shaft nut	13

CONSUMABLES
Immerse the parts in gearbox oil
Loctite FRENLOC:
- 5th speed synchro hub
- Primary shaft nut

DISMANTLING

Separate the clutch shaft from the primary shaft, knocking out the rollpin using drift B.Vi.39.

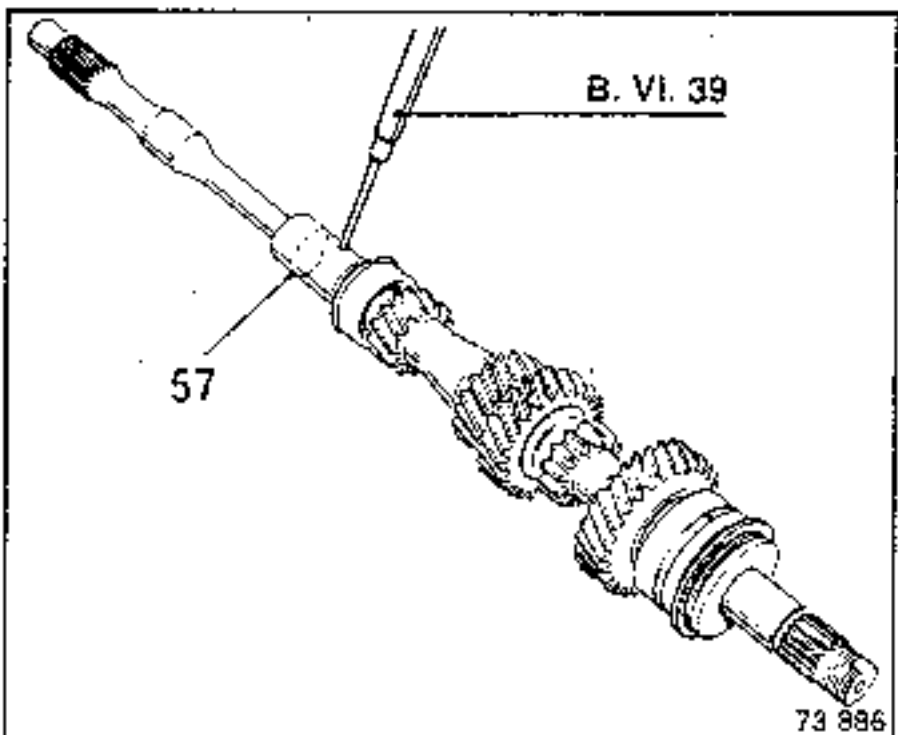

Recover the Grower washer (57).

Remove bearing outer race (56) and its rollers.

ATTENTION: The bearing rollers are not held in place (there is no inner bearing race).

PRIMARY SHAFT

NGO - NG2 (4-speed):

Take out the bearing at the 1st speed end using tool B.Vi.22-01 fitted with shell B.Vi.41.

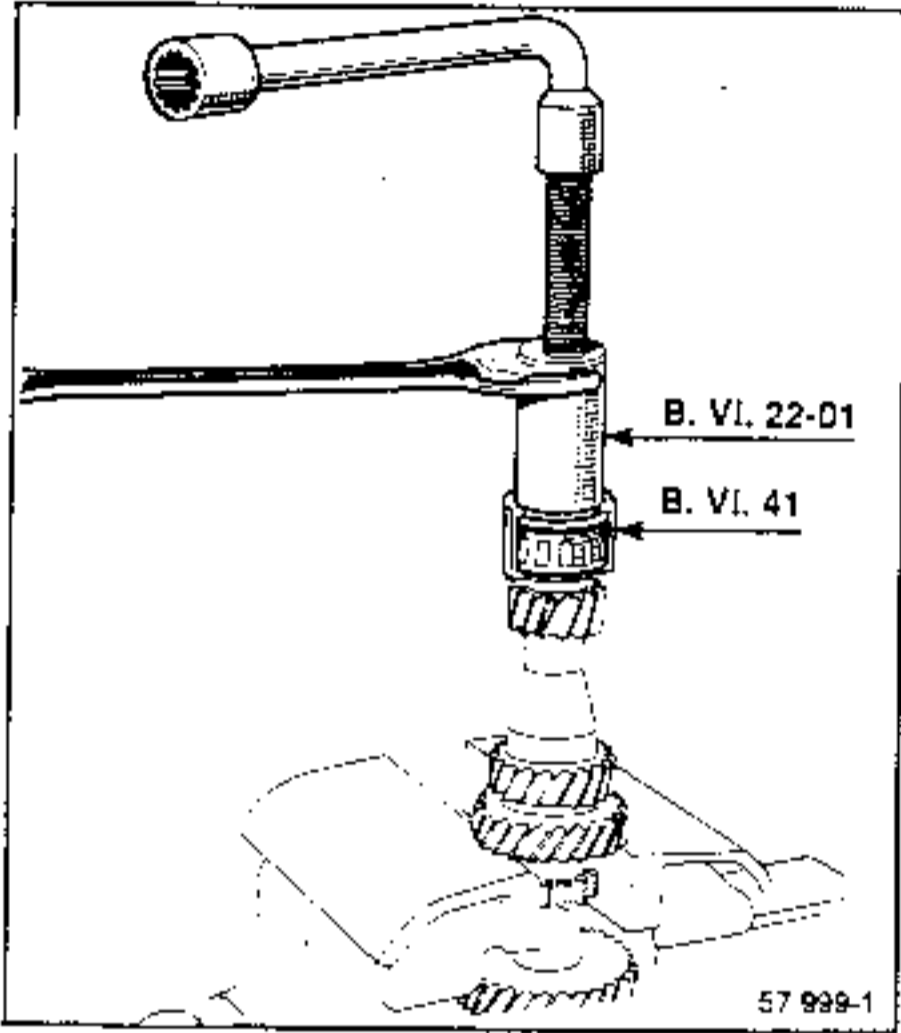

Reassembling:

Fit the bearings on the press.

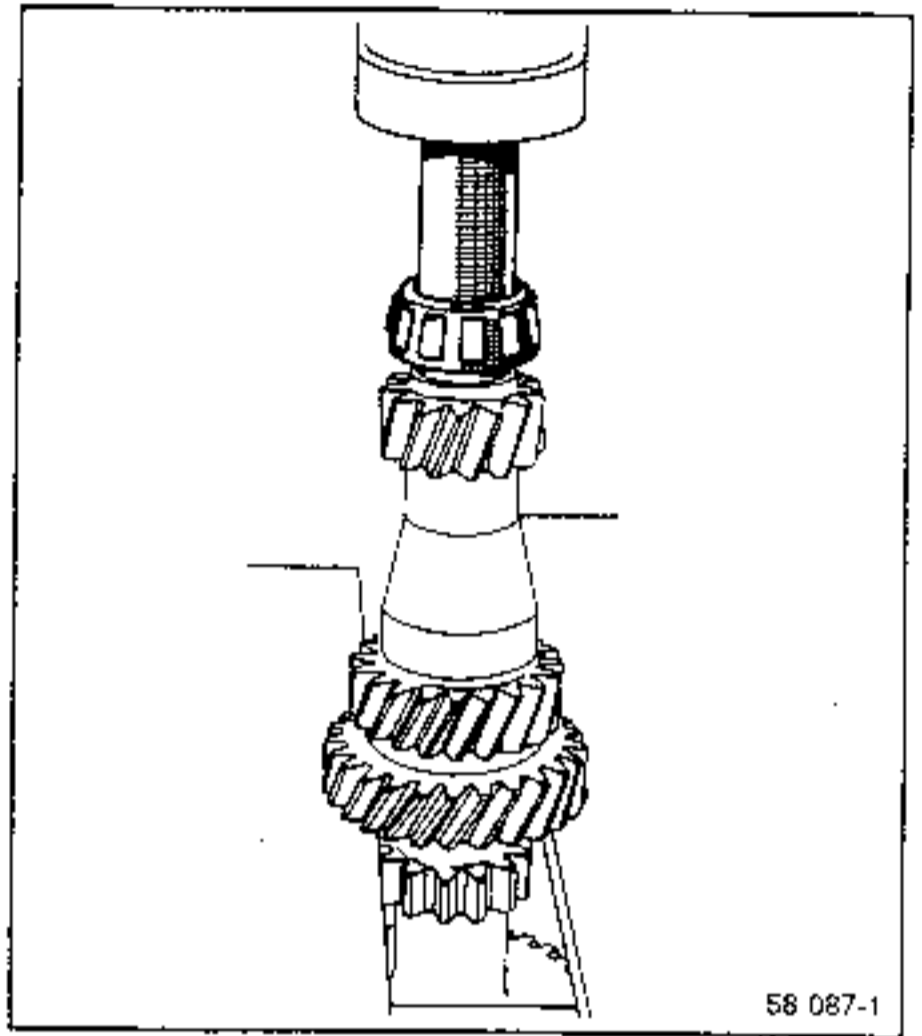

Take out the second bearing using extractor B.Vi.22-01 fitted with shell B.Vi.47.

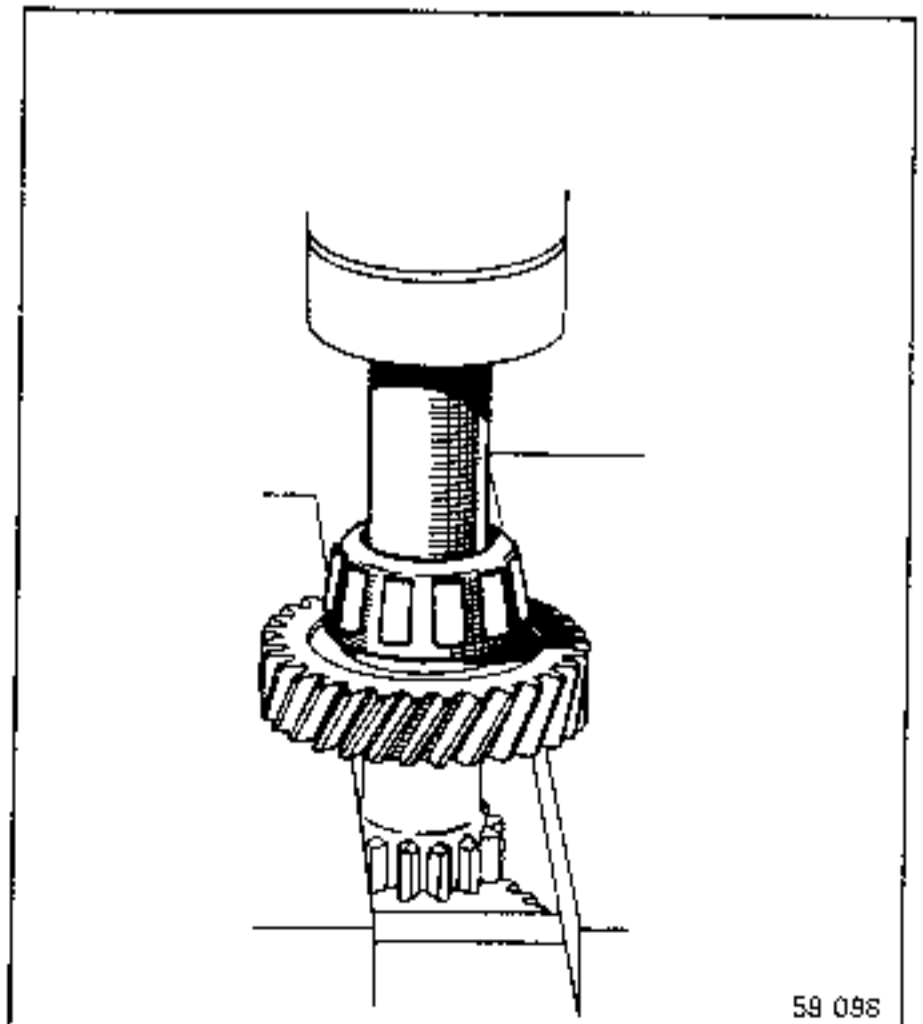
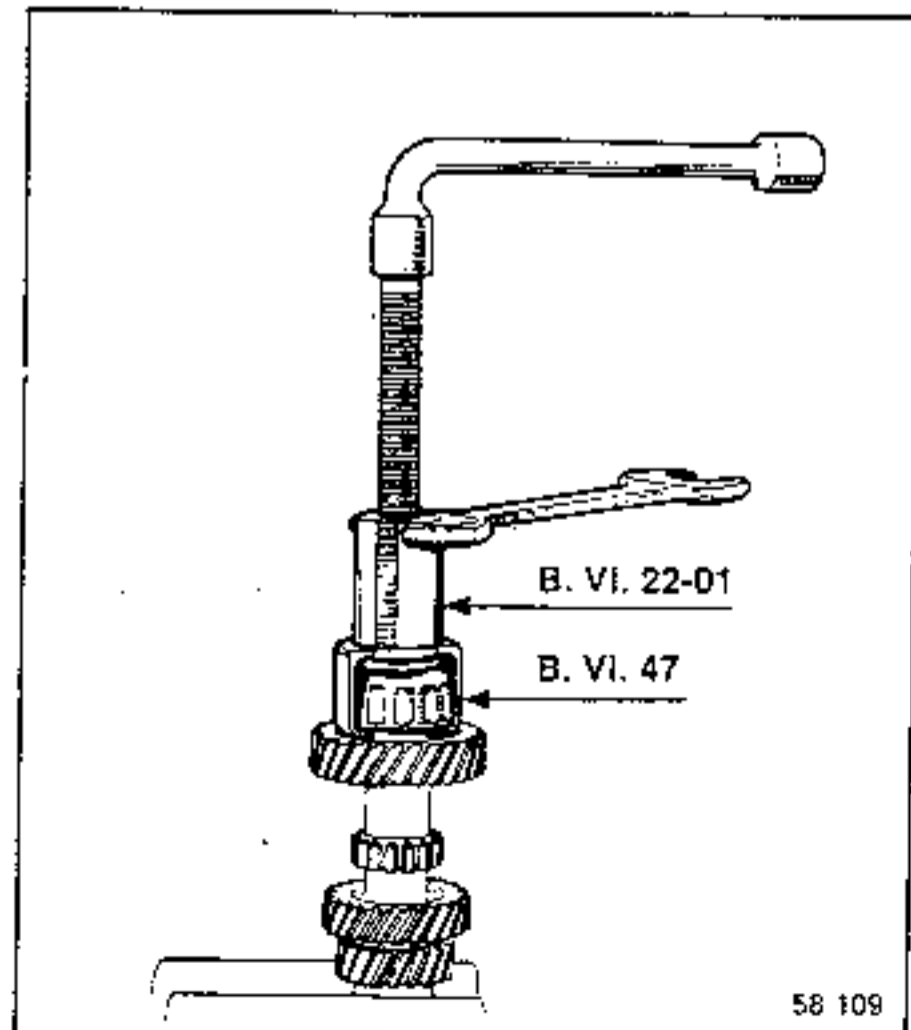

PRIMARY SHAFT

NG - 5 speed:

- Clamp the primary shaft in a vice fitted with soft jaws (near the 4th speed drive gear).
- Release and unscrew the nut (30 mm socket).
- Take the weight under the 5th speed idler gear to take the hub out of the synchro.

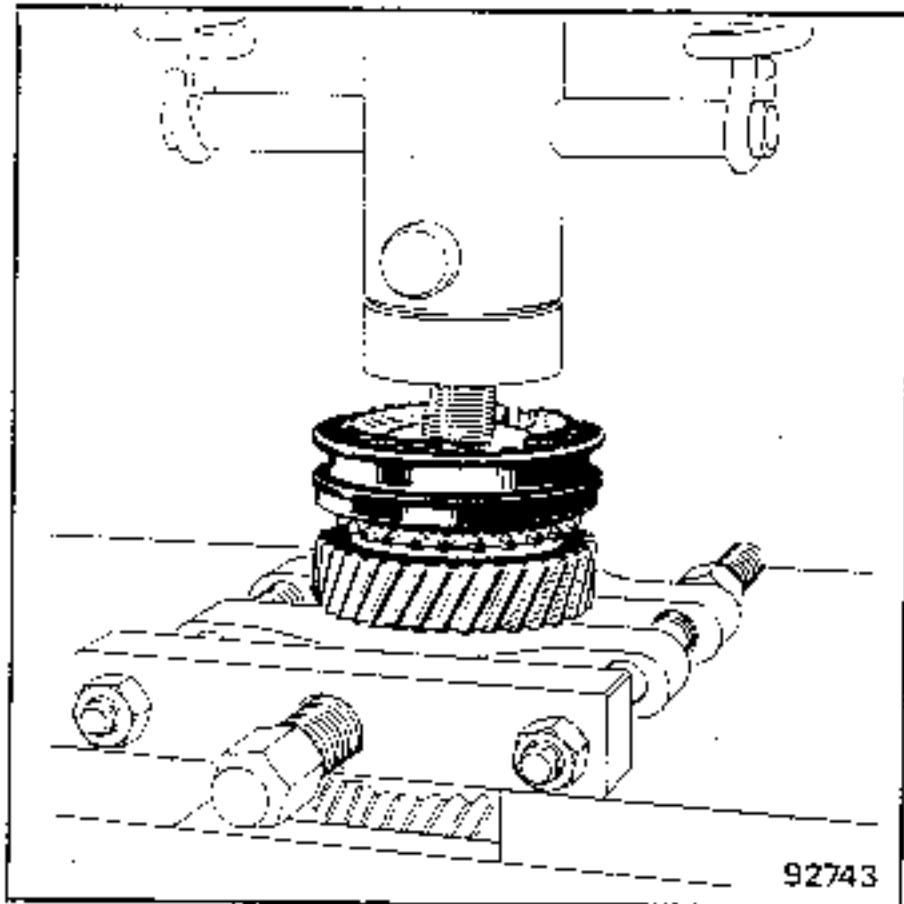

At the 5th speed drive gear end the primary shaft is fitted with:

1st type

A bearing with a double row of balls 1.

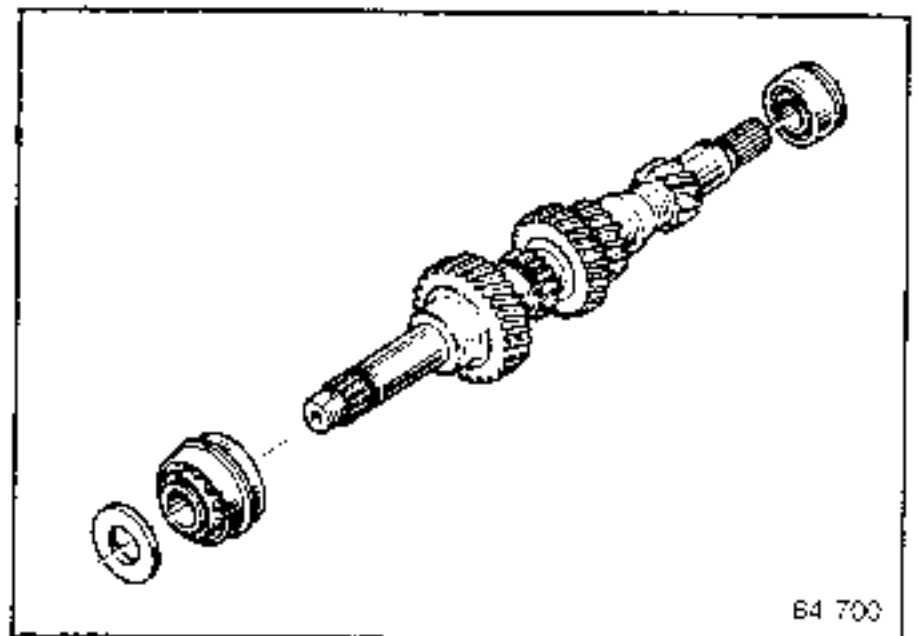

2nd type

A bearing with tapered rollers 2.

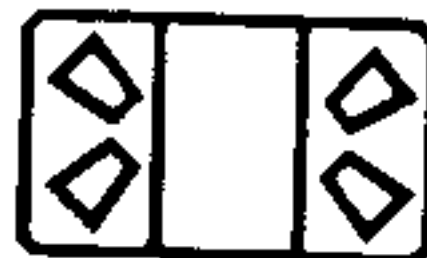

These bearings are removed and refitted by hand.

PRIMARY SHAFT

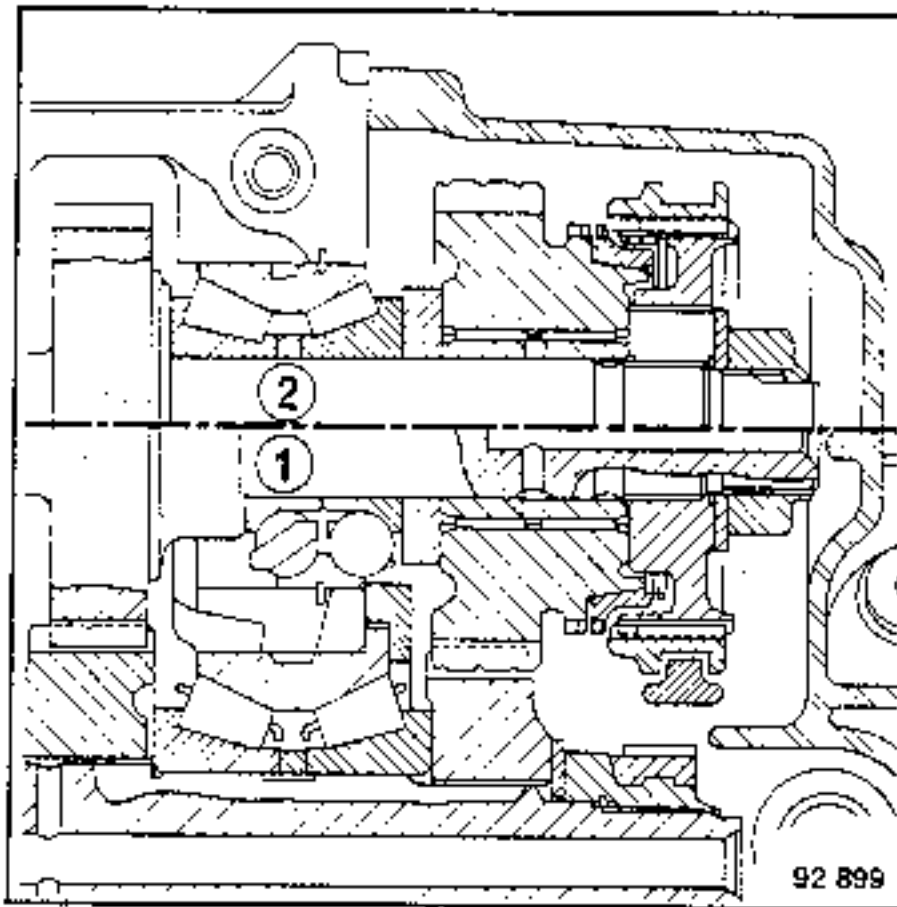

Bond the 5th speed synchro hub with **Loctite FRENBLOC** and ensure that the assembly is fitted the correct way round.

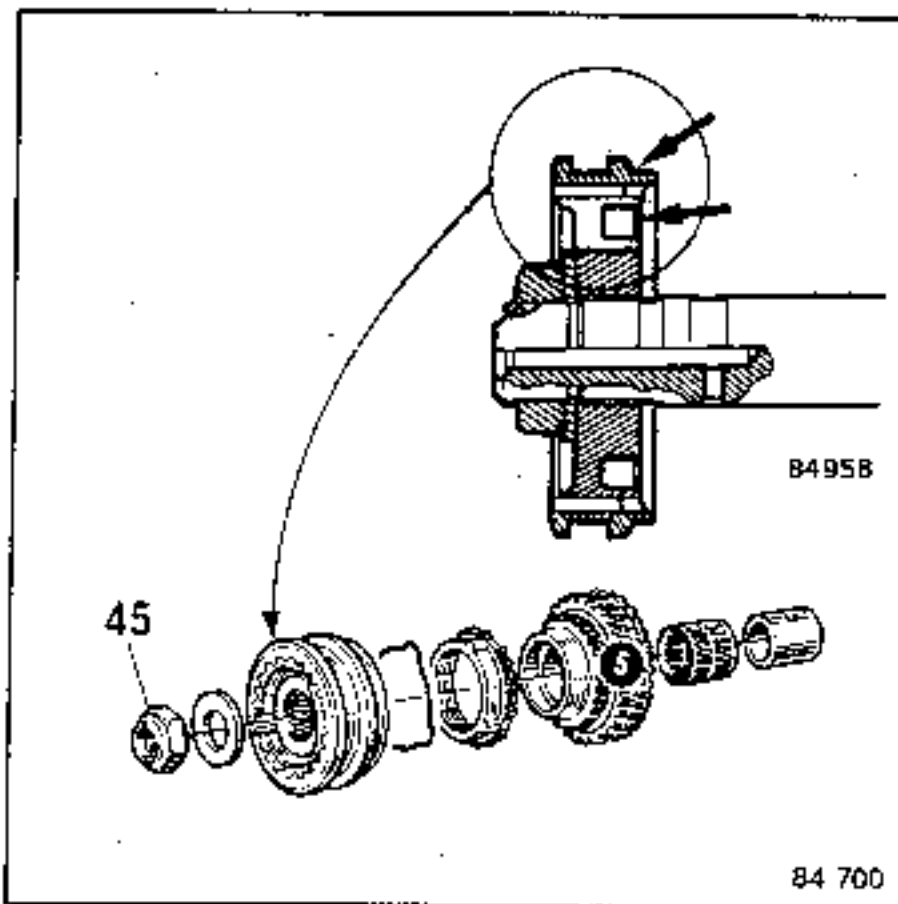

Fit the bosses on the synchro ring in the notches in the hub.

Put 3 drops of **Loctite FRENBLOC** on the threads of the new nut, torque tighten it and lock it.

SECONDARY SHAFT

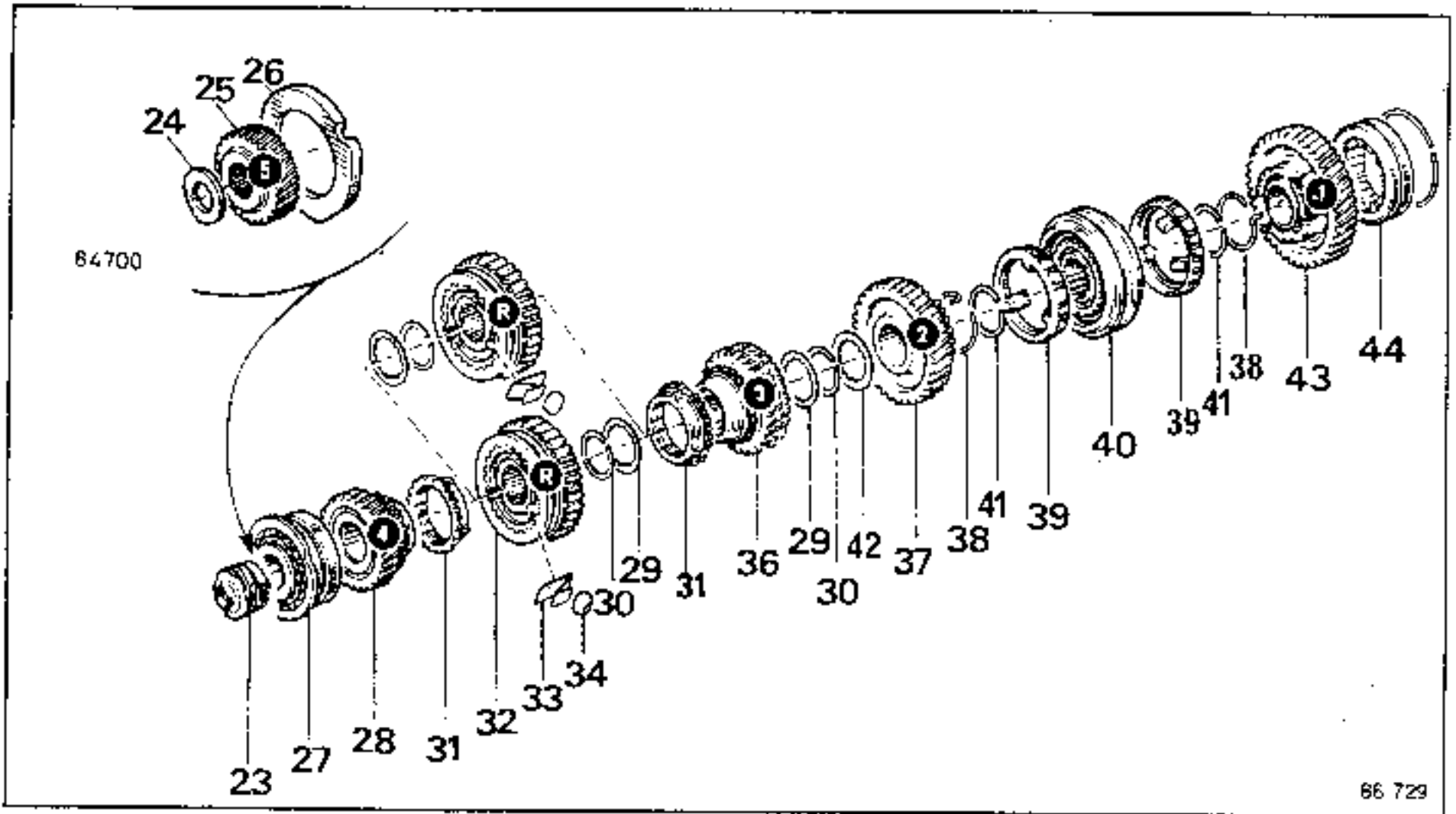

Dismantling - Reassembly

This operation is performed after the casings have been separated.

TIGHTENING TORQUES (in daNm)

Secondary shaft nut (except NG7)	15
NG7 secondary shaft nut	20

CONSUMABLES

Immerse all the parts in gearbox oil
Loctite FRENBLOC:
- 5th speed fixed gear
- Secondary shaft nut

SECONDARY SHAFT

Dismantling

Clamp the secondary shaft in a vice fitted with soft jaws (near the 1st speed drive gear).

Engage first gear (as shown by the arrows in the diagram).

Release and unscrew the nut using tool B.Vi.204-01.

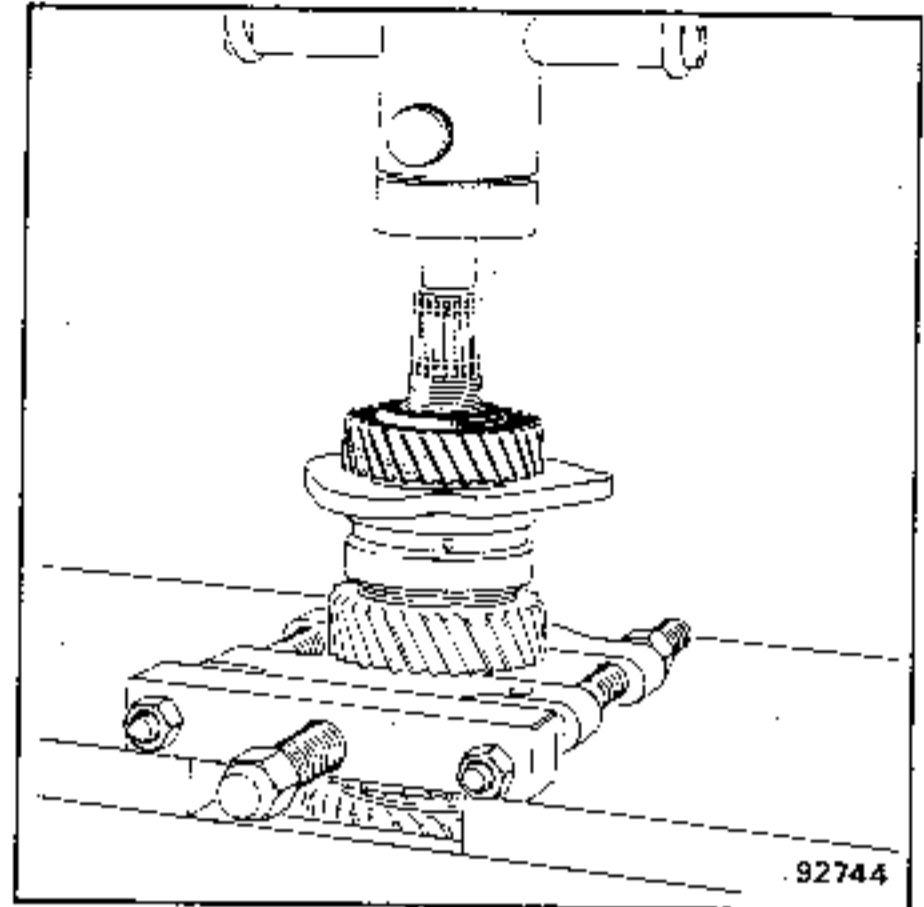
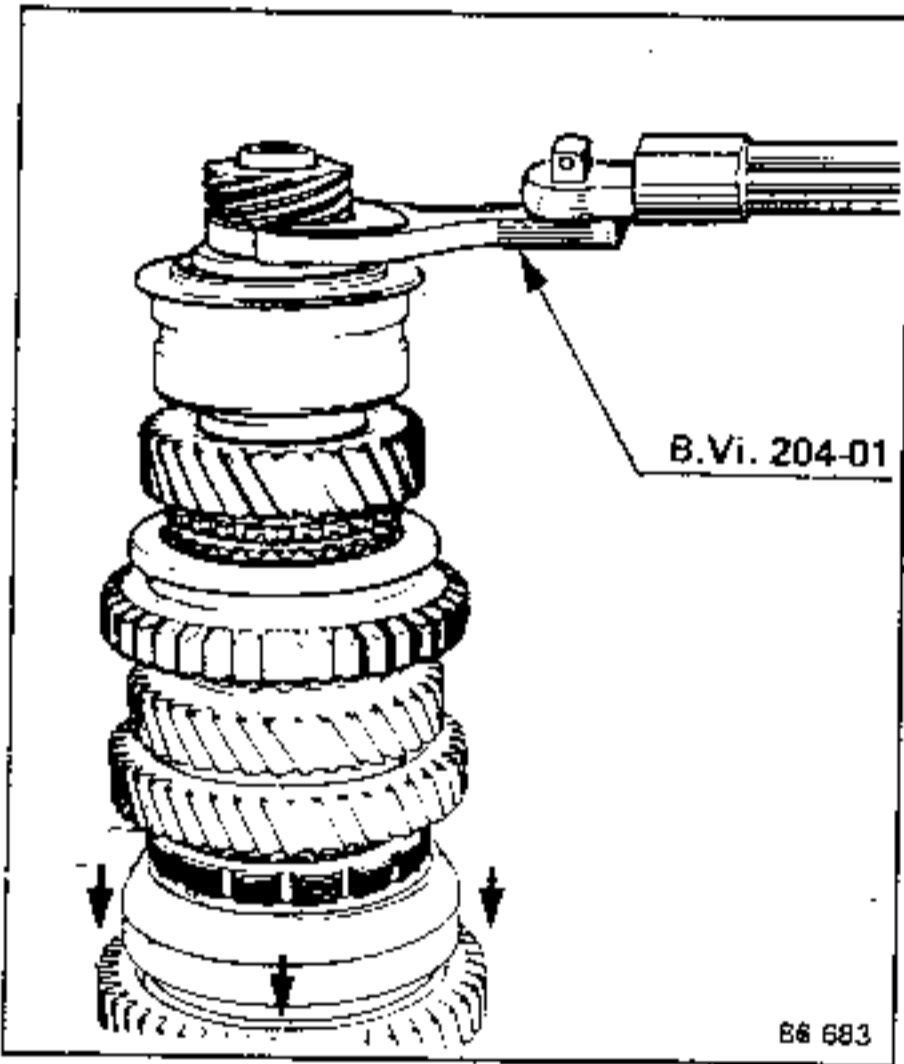

NG7 - Special point:

Remove:

- the snap ring;
- the dog clutch drive using an extractor of the FACOM U32-120 type or similar;

5-speed gearboxes:

Take the weight under the 4th speed drive gear and take out the 5th speed fixed gear assembly and bearing.

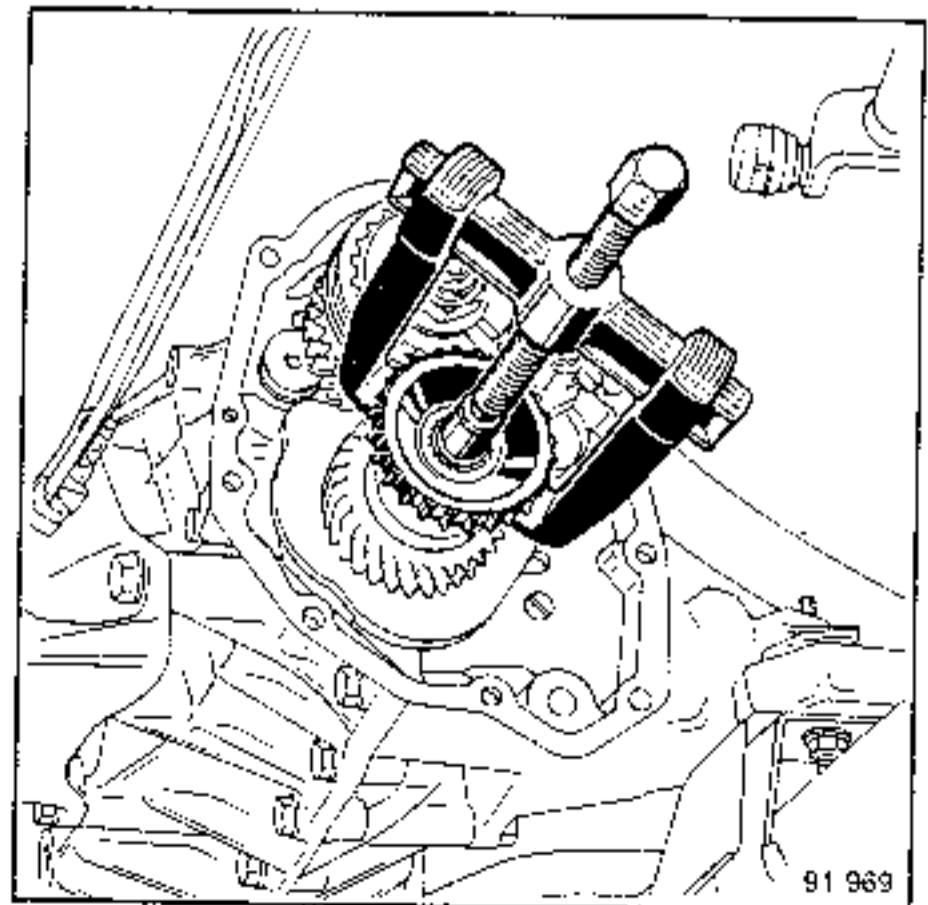

- the nut using a 36 mm long socket (for example FACOM K36LA).

SECONDARY SHAFT

Dismantling

The hubs are free-mounted and held by snap rings so they cannot move sideways.

To remove the snap rings, use circlips pliers on one side to move the jaws apart and flat-ended pliers on the opposite side so that the snap rings do not twist.

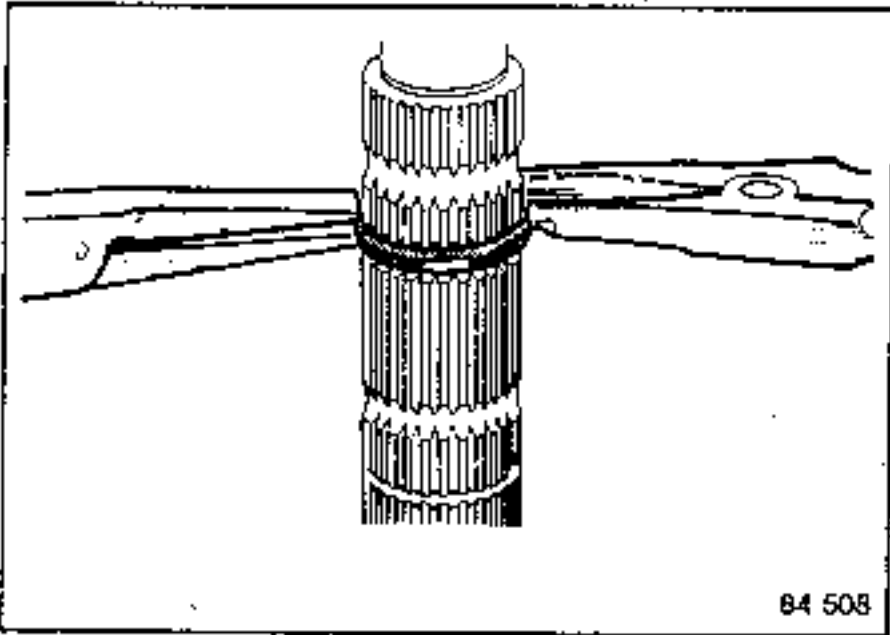

The snap rings cannot be used again. They must be replaced systematically.

Mark the hubs (M) in relation to slide gears (B).

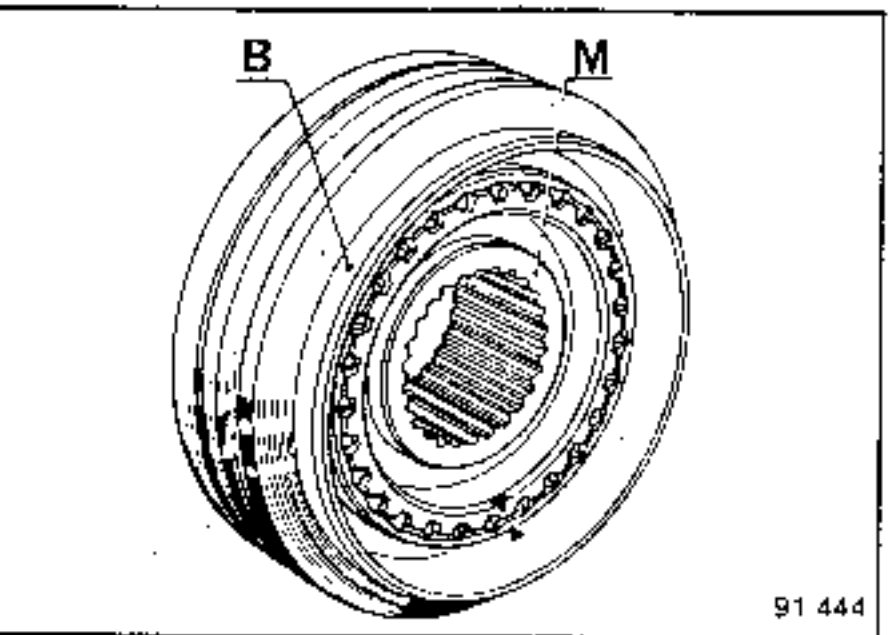

Before removing snap ring (41) in front of the 1st speed drive gear, remove the secondary shaft from the vice since it is no longer held in place.

ATTENTION: The rollers of bearing (44) are not held in place on the secondary shaft (no inner track ring).

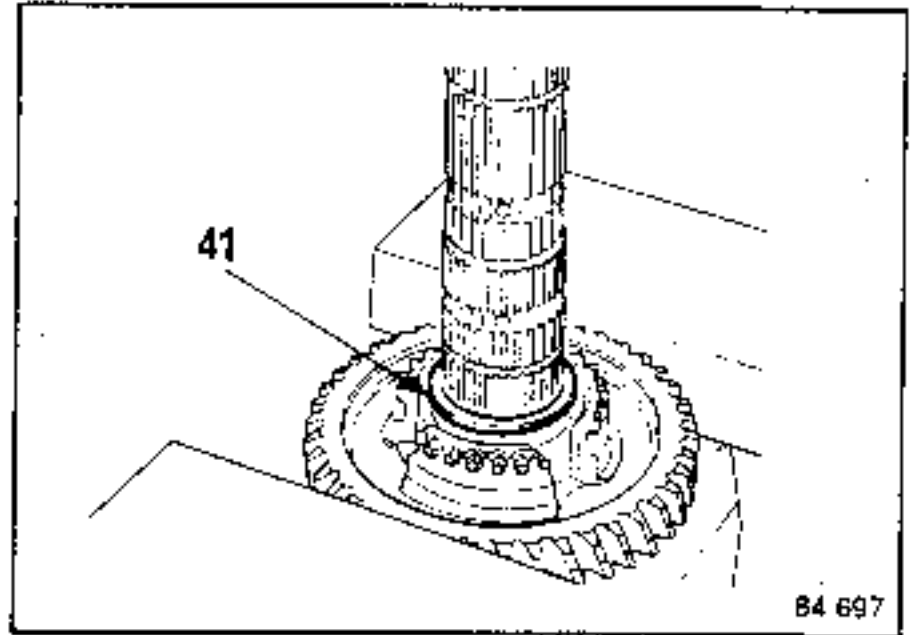

NOTE:

The bearings must be replaced as soon as any scratches, hot spots or excessive wear is noticed.

The teeth of the drive gears and dogs must never have notches on them or be excessively worn. You must also ensure that the surfaces of the shaft and the internal walls of the drive gears do not show any signs of seizure or abnormal wear.

Hubs - Slide gears:

Ensure that the hubs and their slide gears are not notched and that they move smoothly, without excessive play or jamming.

SECONDARY SHAFT

Reassembly

Replace the snap rings systematically whenever they have been dismantled.

. 1st/2nd speed synchro and idler gears

Place the synchro rings on the 1st and 2nd drive gears with the ends folded into the aperture in the drive gears.

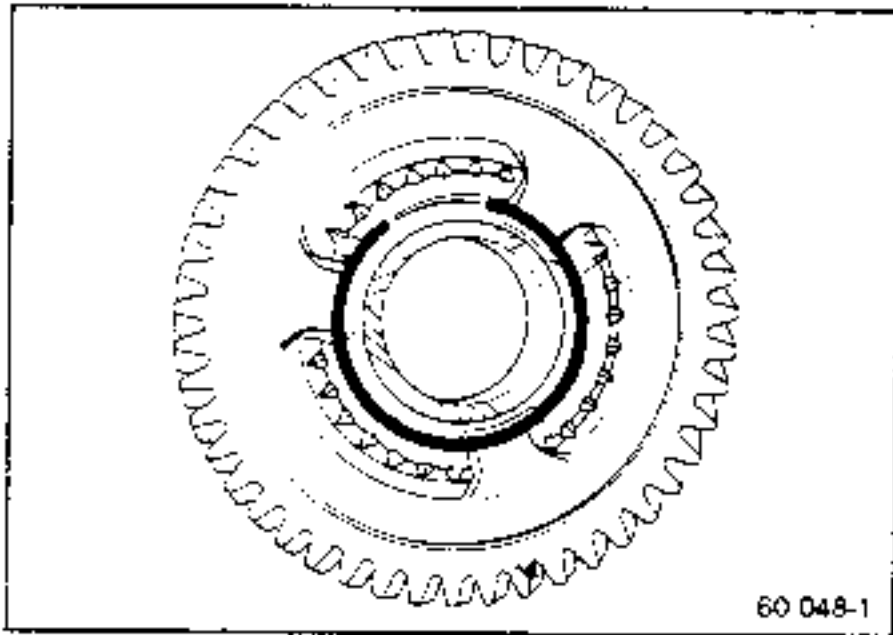

- the 1st/2nd speed slide gear, with the chamfer at the 2nd speed end.

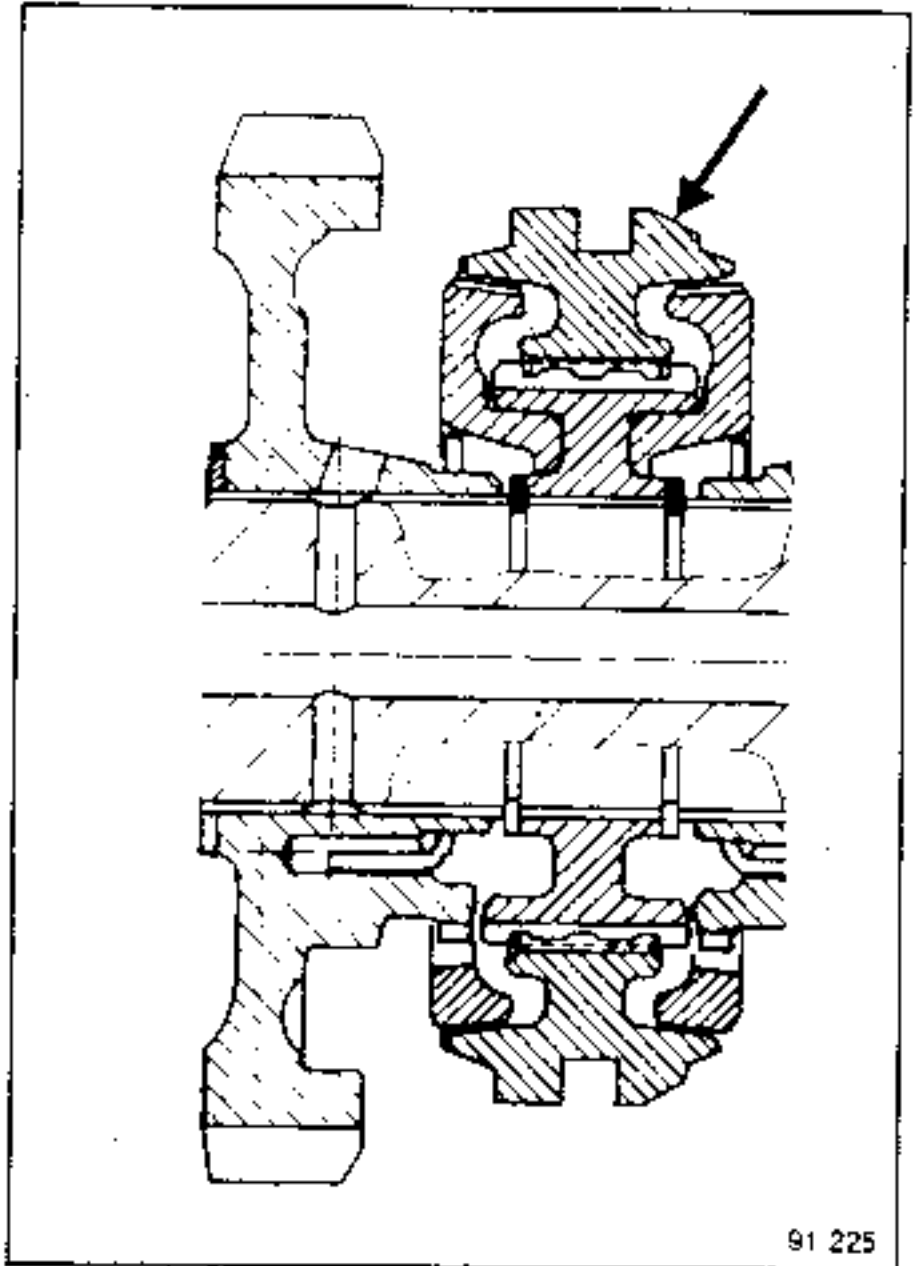

Ensure that the following are fitted in the correct direction:

- the bearing bush under the head, with the large offset at the 1st speed drive gear end;

The 1st/2nd and 3rd/4th speed hubs are a slide fit on the secondary shaft. On reassembly, find the position in which they slide most freely on the shaft.

Take care to align the notches on the idler gear with the lugs on the synchro ring.

SECONDARY SHAFT

• 3rd/4th speed synchro and idler gears

There are two possible types of assembly for the 3rd/4th speed synchro hub depending on whether the secondary shaft (S) is dimension x or y.

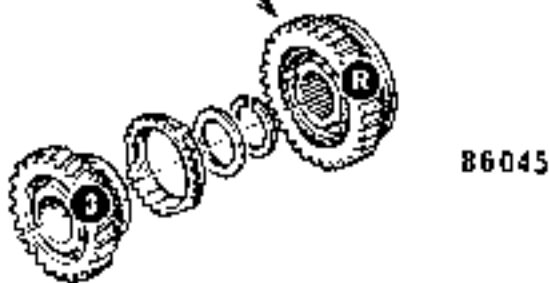
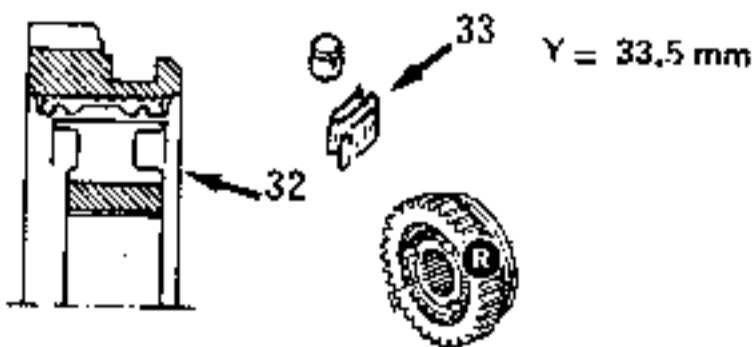
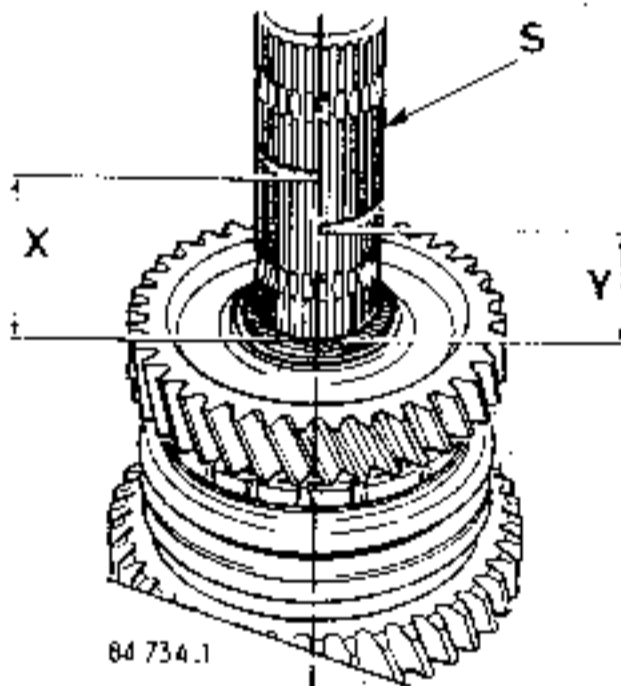
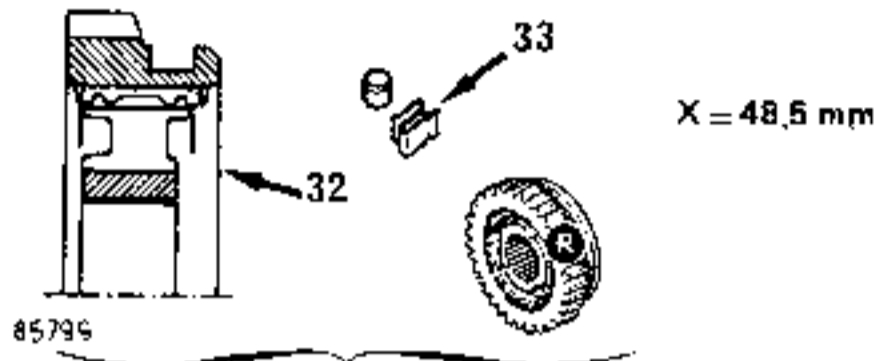

ATTENTION:

Two types of synchro roller spring are used: the "Z"-shaped springs have been replaced by "heart-shaped" springs.

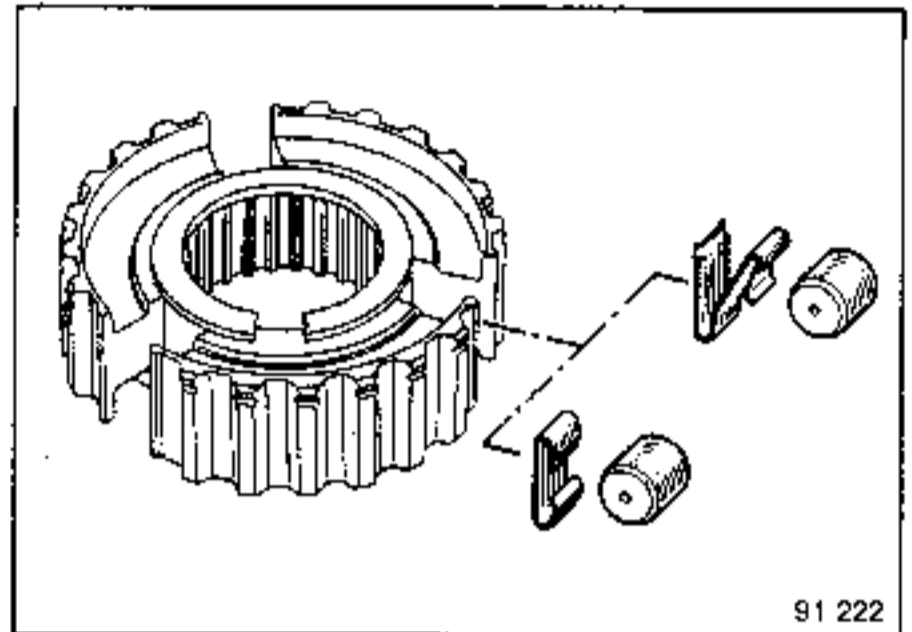

In order that heart shaped springs can be fitted, inlet chamfer (E) for the bevel shoulder under the 3rd and 4th speed idler gear synchros has been modified.

Consequently, the heart-shaped springs can only be used with modified idler gears.

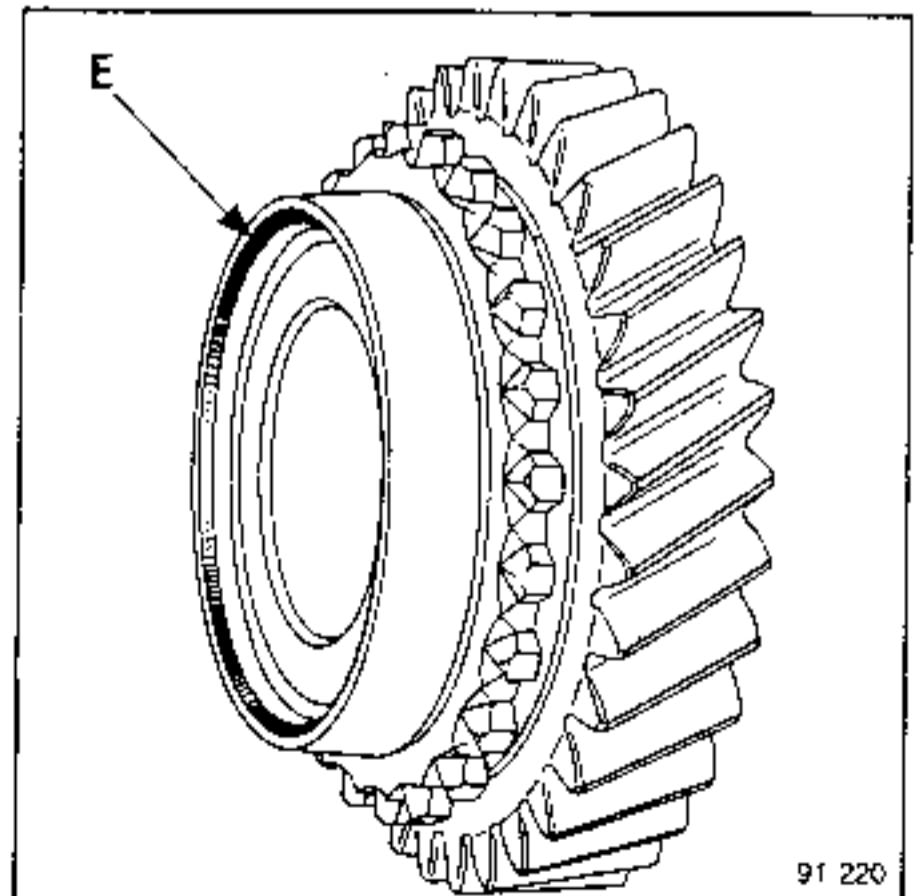

SECONDARY SHAFT

Detail (E) of the idler gear

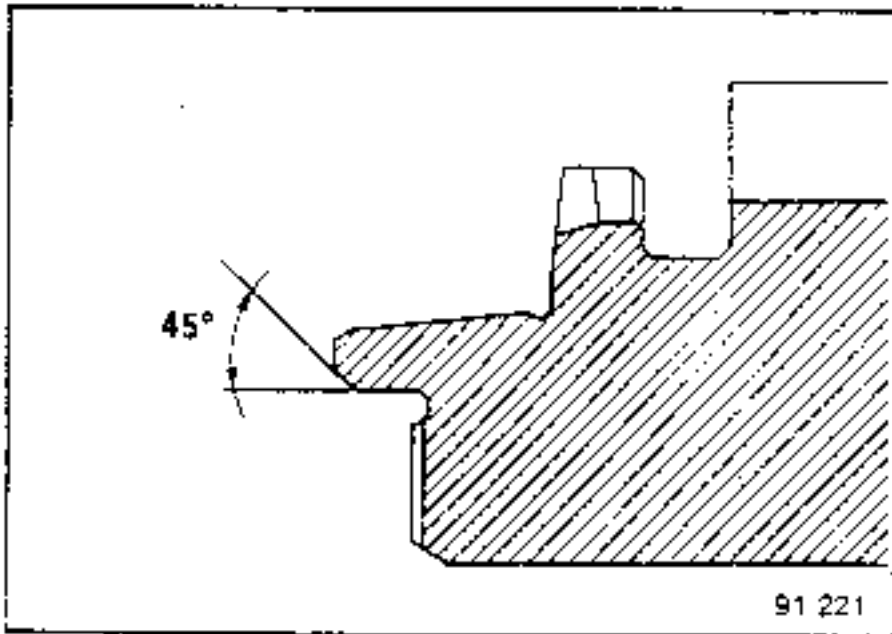

45° inlet chamfer (E) for the bevel shoulder under the synchro ring can only be fitted with the Z-shaped spring.

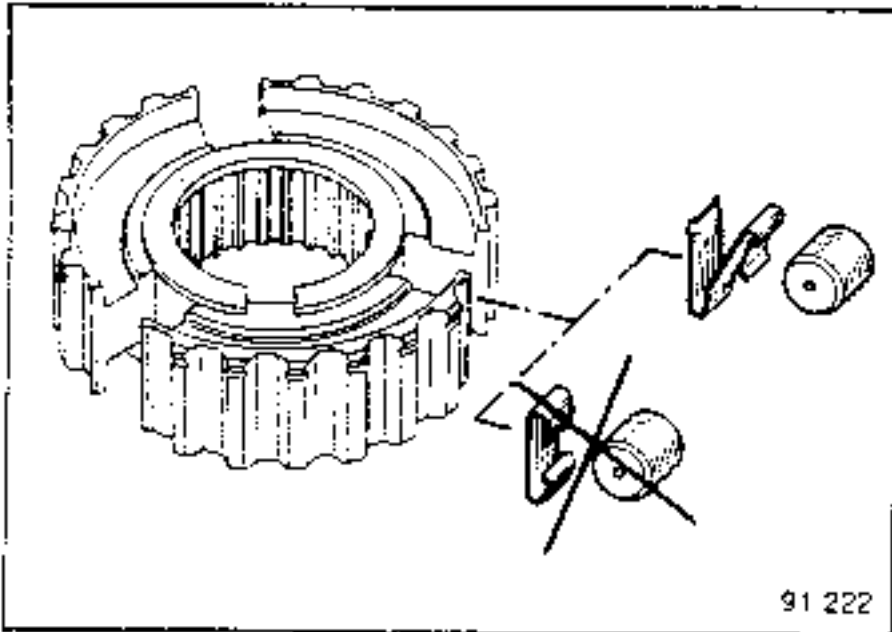

Remember:

The Z-shaped springs for the synchro rings must be fitted with the locking tabs at the snap ring end.

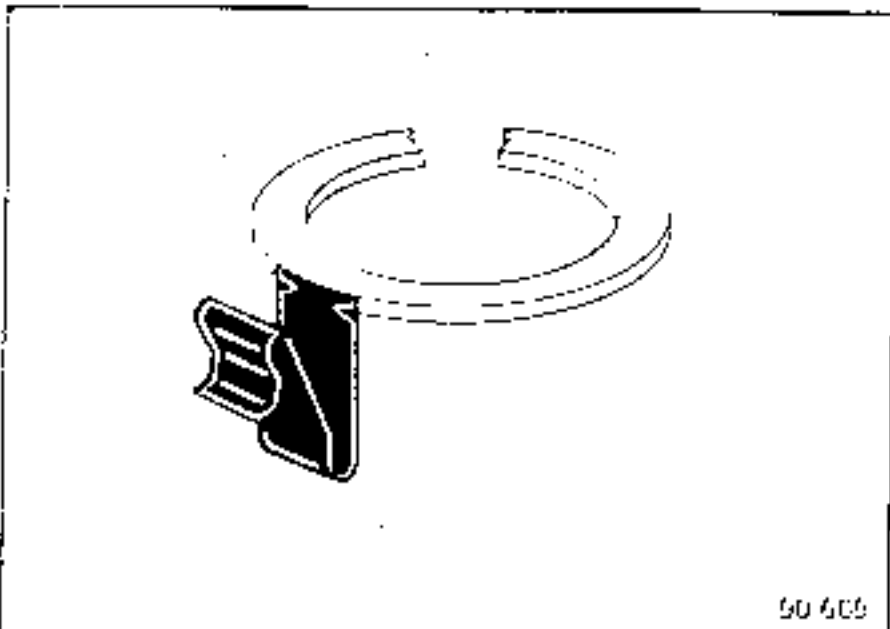

Detail (E) of the idler gear

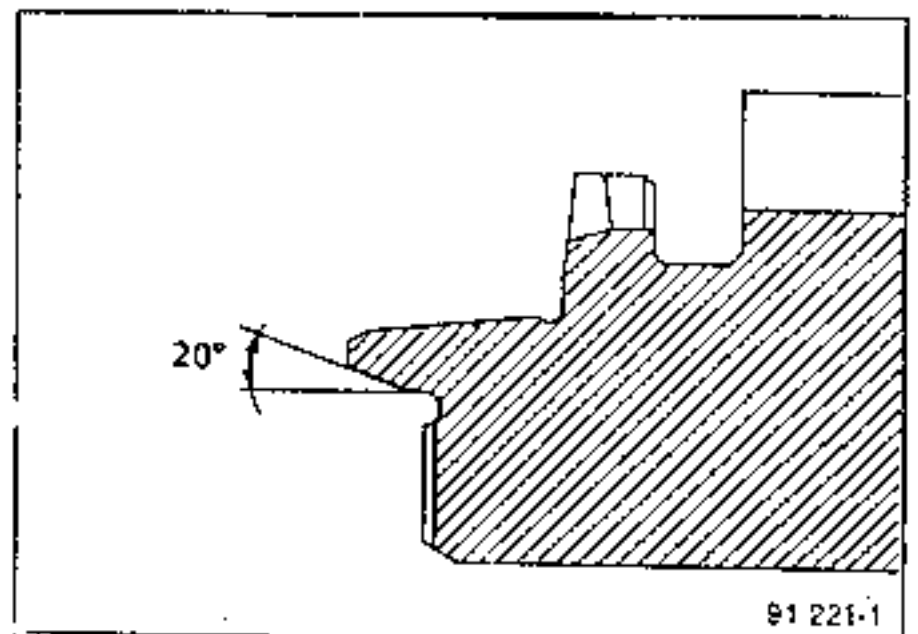

Special point:

Idler gears with a 20° inlet chamfer (E) can be fitted either with the heart-shaped or the Z-shaped springs. However, the two types of spring must not be used on the same synchro assembly.

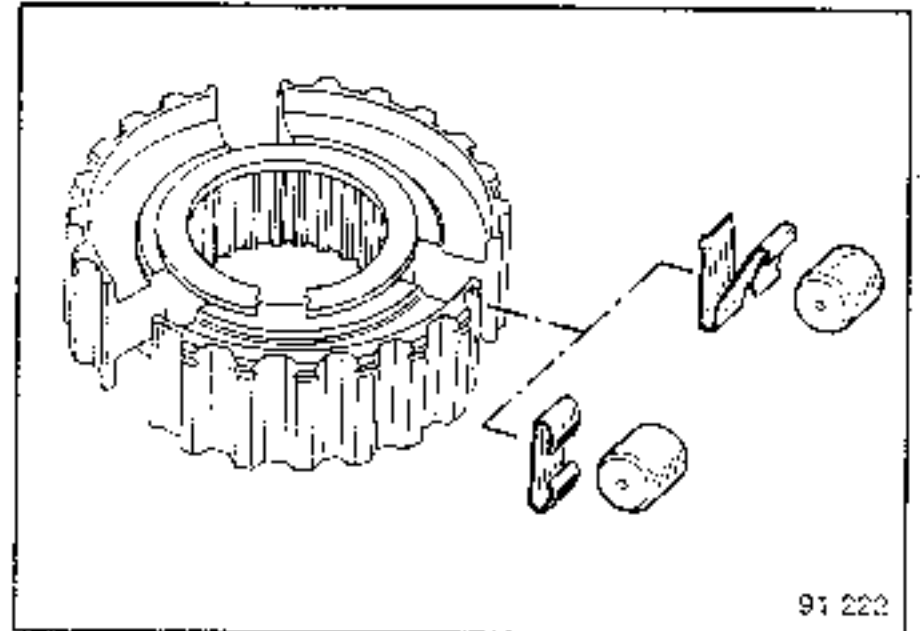

Make sure that the heart-shaped springs are fitted with the flat part at the synchro hub end.

Ensure that the notches on the hub are aligned with the bosses on the synchro ring.

SECONDARY SHAFT

Fit:

- the the set of taper roller bearings, checking that the pre-load spacer is fitted between the two cones.
- the bearing thrust plate.

Make sure that the fixed gear is fitted the correct way round and bond it with **Loctite FRENBLLOC**.

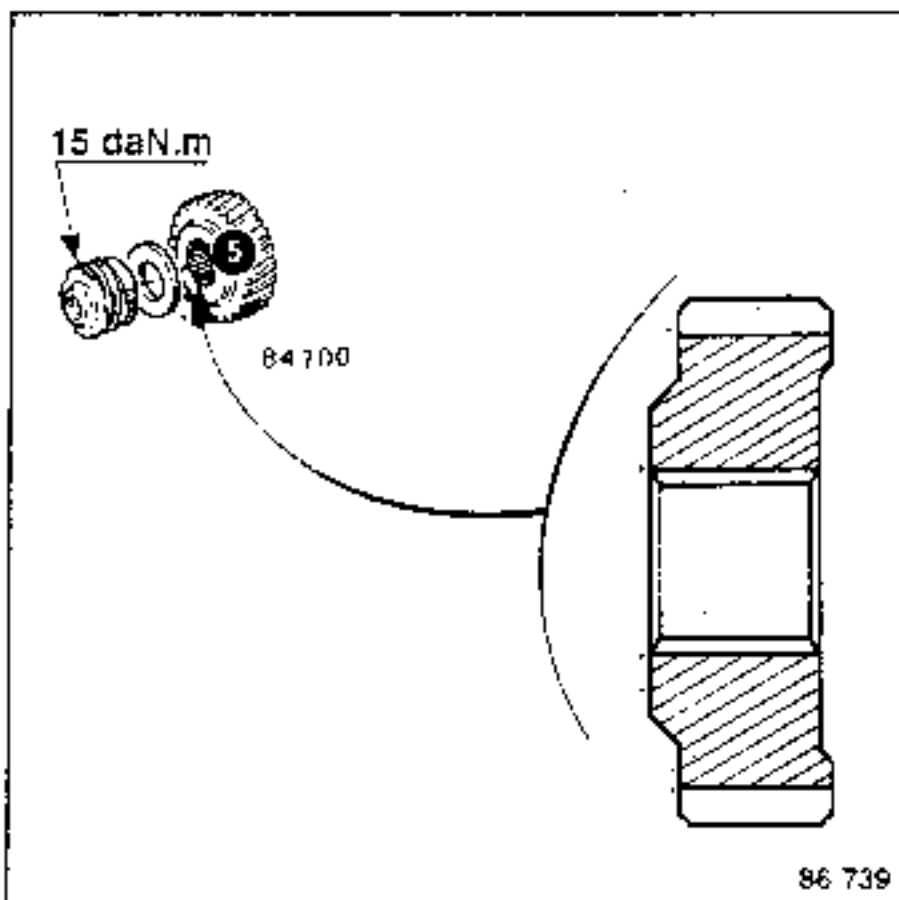

Fit the spring washer.

Put 3 drops of **Loctite FRENBLLOC** (120° apart) on the threads of the new nut, torque tighten and lock it.

NOTE: When tightening the nut, rotate the set of taper roller bearings to ensure that they locate correctly.

NG7: Special points

Checks to be carried out:

- the 5th speed fixed gear torque - it must be greater than 1000 daN;
- the secondary shaft guide end out-of-round - it must be less than 0.15 mm.

Fit:

- the snap ring;
- the dog drive (sealed with **Loctite FRENBLLOC**);
- the second snap ring.

REVERSE GEAR SHAFT

This operation is performed after the casings have been separated.

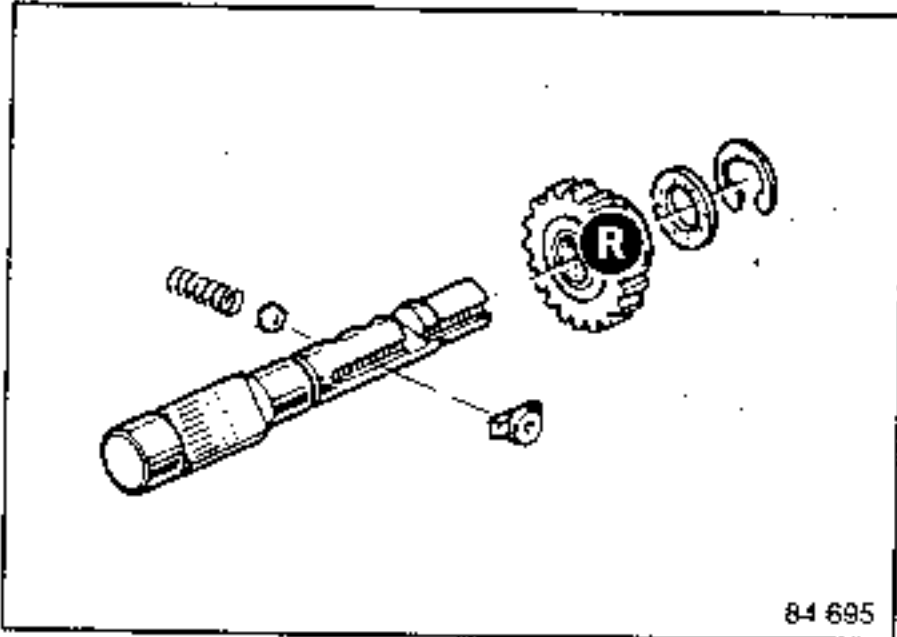

DISMANTLING

Remove the circlip holding the drive gear and take out the shaft, drive gear, friction washer and guide.

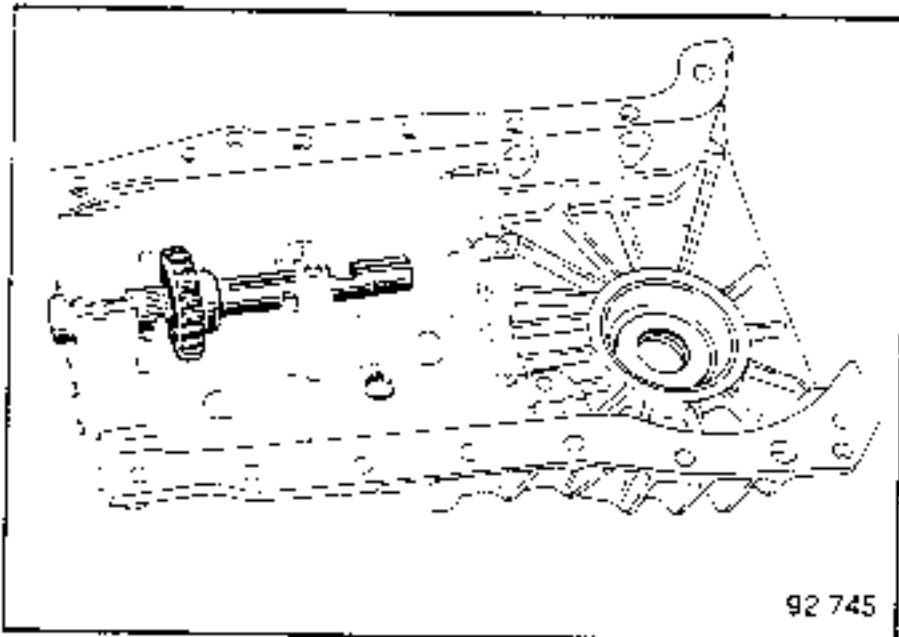

REASSEMBLY

In the half-casing:

- place the locking ball and spring;
- engage the shaft and fit the drive gear (with the hub at the differential end) then the friction washer (bronze face at drive gear end);
- fit the guide from inside the bore and engage the shaft completely;

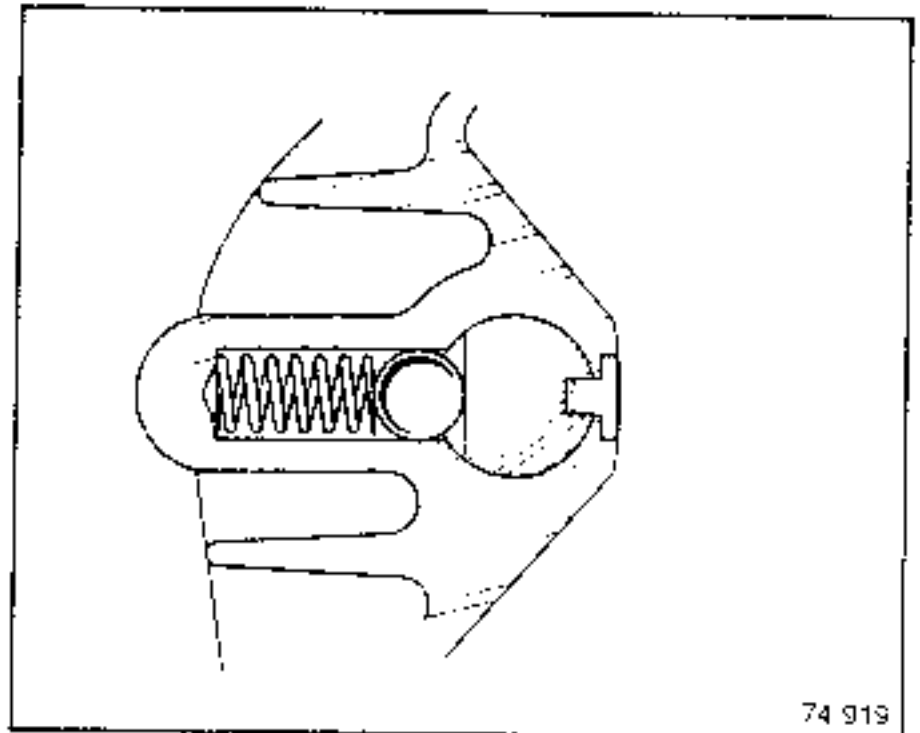

- fit the drive gear retaining circlip and check that it sits correctly in the groove on the shaft.

DIFFERENTIAL

CROSS-SECTION

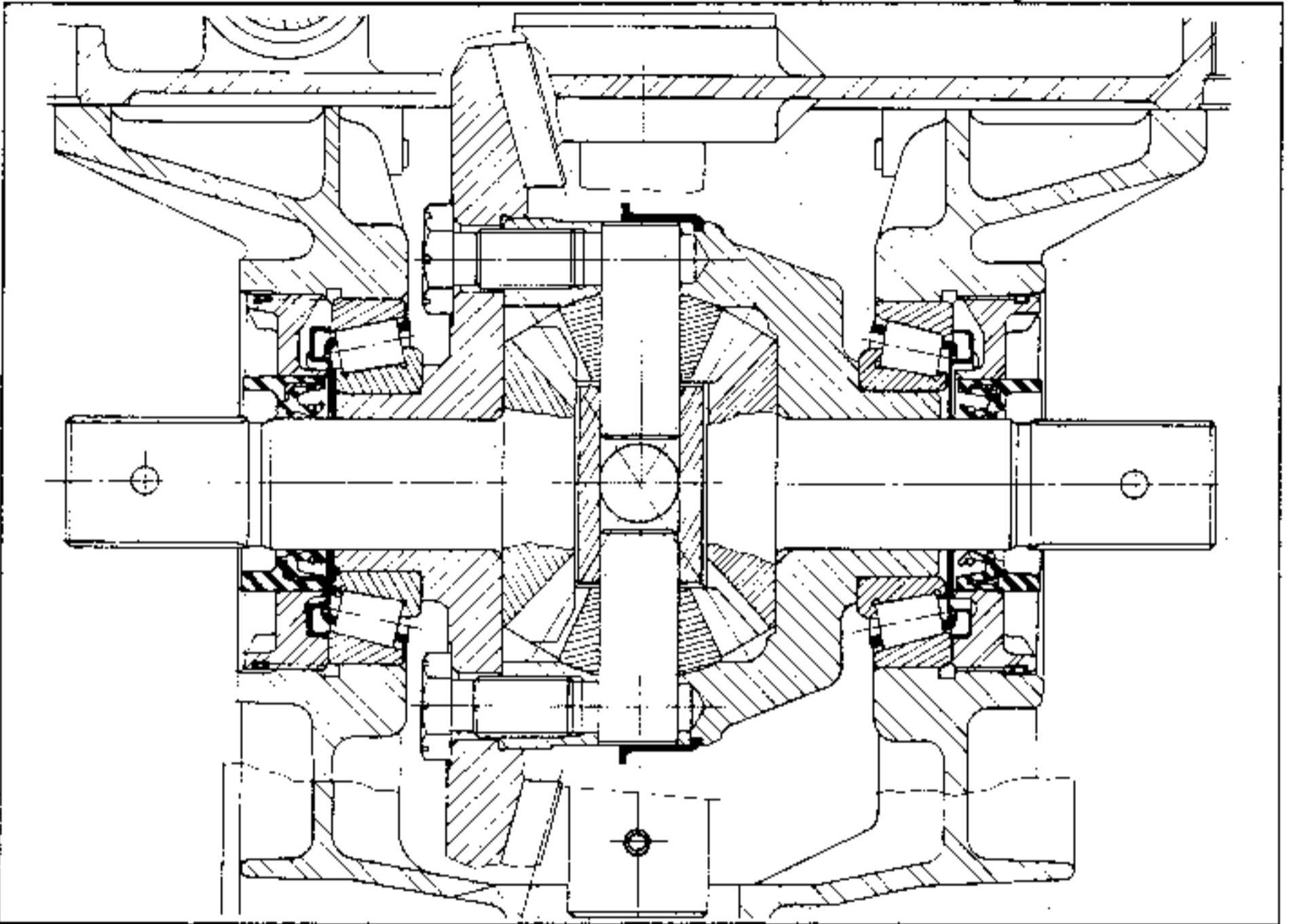

Dismantling - Reassembly

This operation is performed when the casings have been separated.

TIGHTENING TORQUES (in daNm)

Crown wheel bolts	
- NG0 - 1 - 5.....	10
- NG2 - 3 - 7 - 9.....	12.5

CONSUMABLES

Immerse the parts in gearbox oil
Loctite FRENLOC: Crown wheel bolts

**DIFFERENTIAL
Dismantling:**

Remove the two bolts securing the crown wheel.

Take out the bearings at the crown wheel and housing ends using tool B.Vi.28-01 fitted with jaws B.Vi.48 or a similar type of extractor.

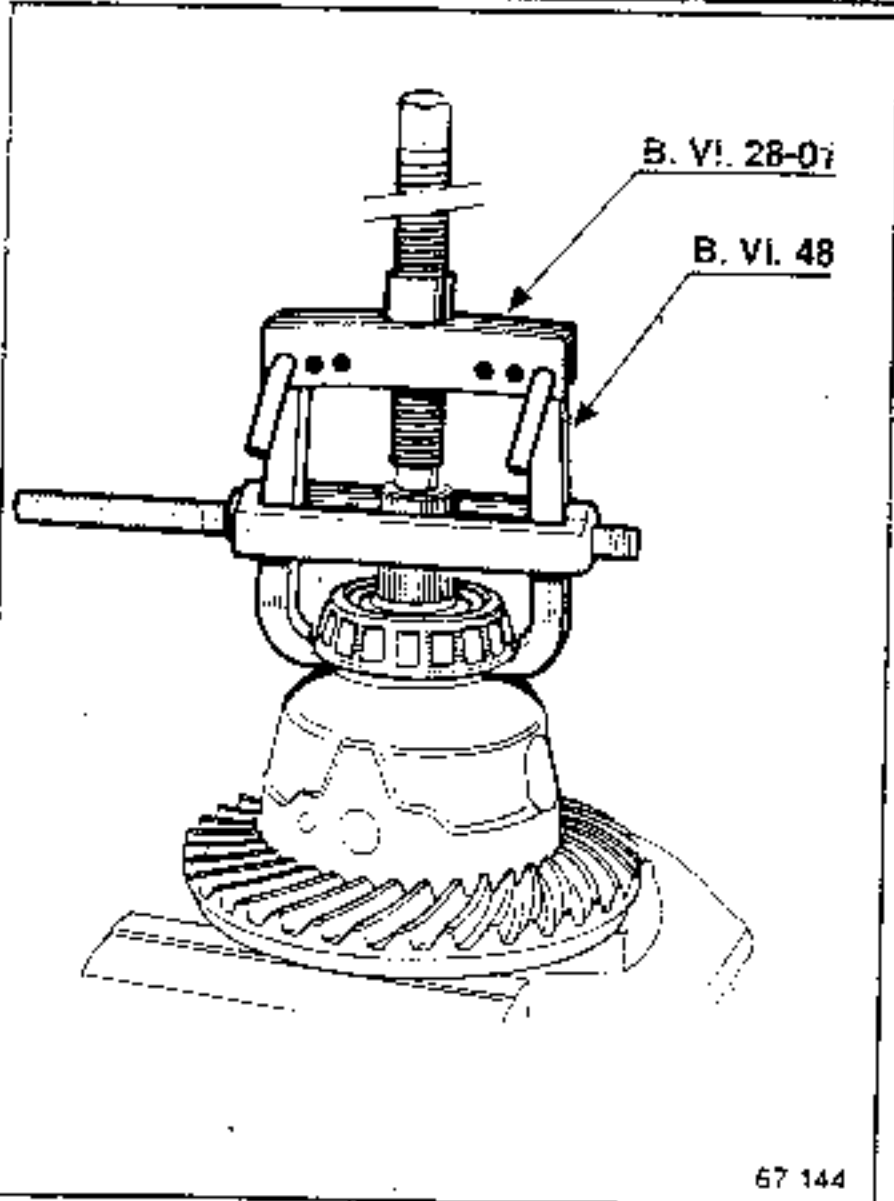
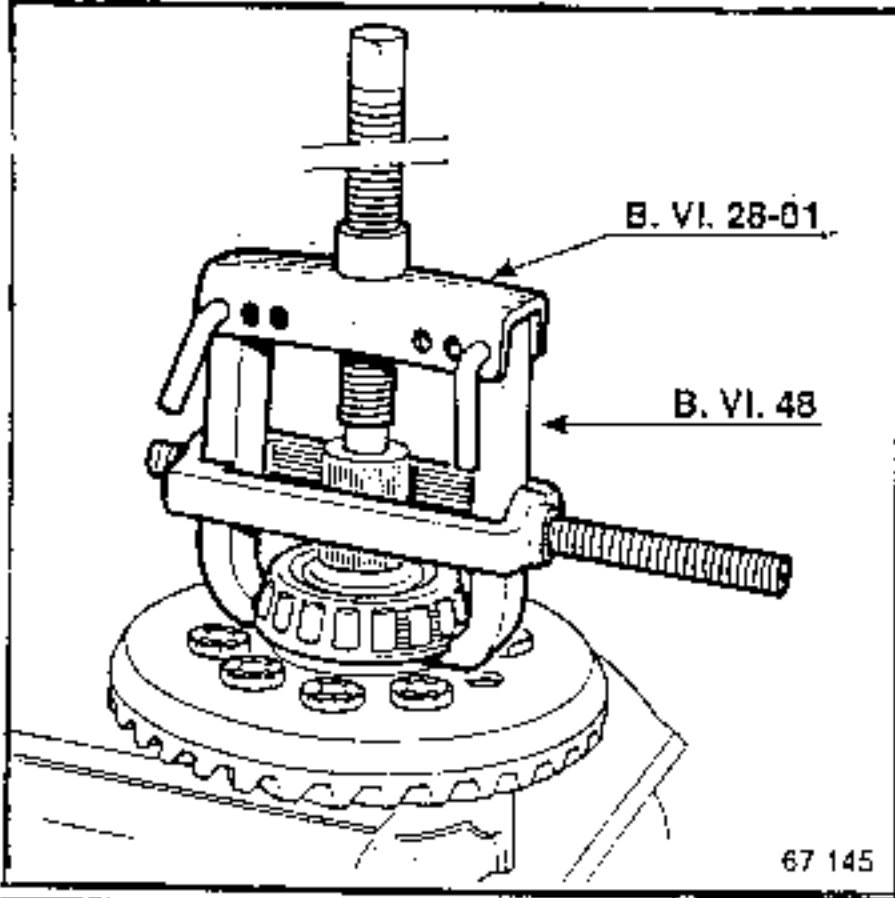

Differential with two planet wheels:

Knock out the spring pin holding the planet wheel shaft using drifts B.Vi.31-01 or B.Vi.39.

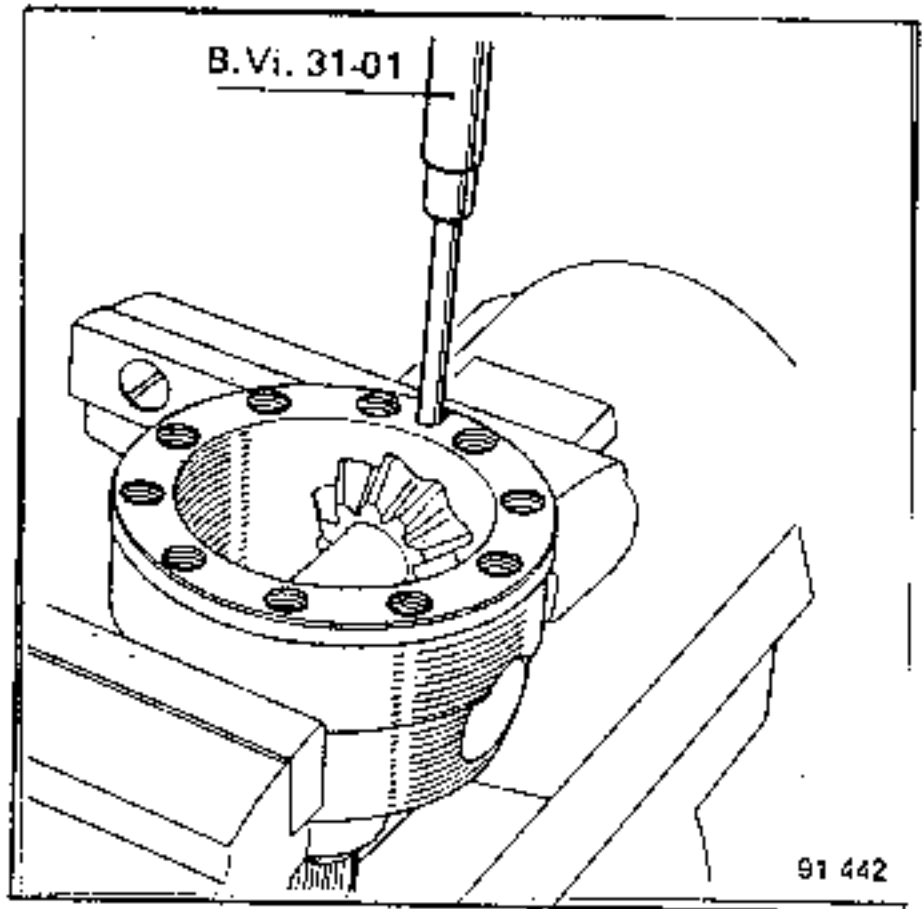

Separate the various parts.

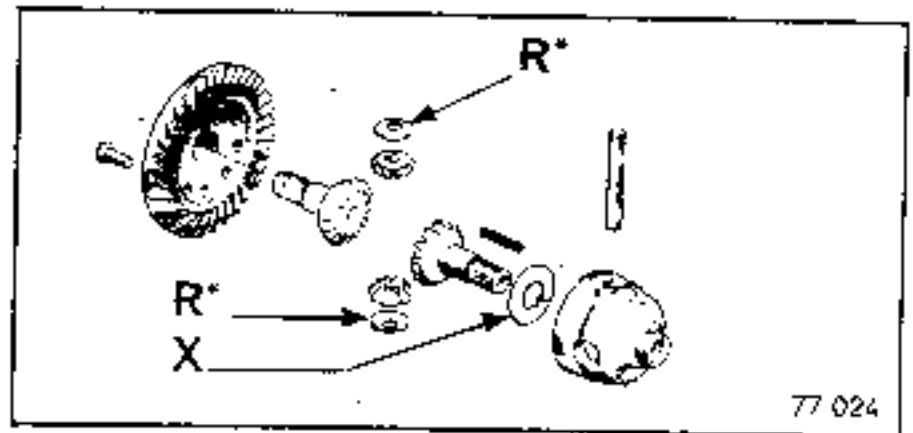

*Depending on type of assembly.

Attach washers (R) to their respective planet wheels and recover shim (X).

Differential with four planet wheels and collar

Destroy collar (69) using a chisel and separate the various parts.

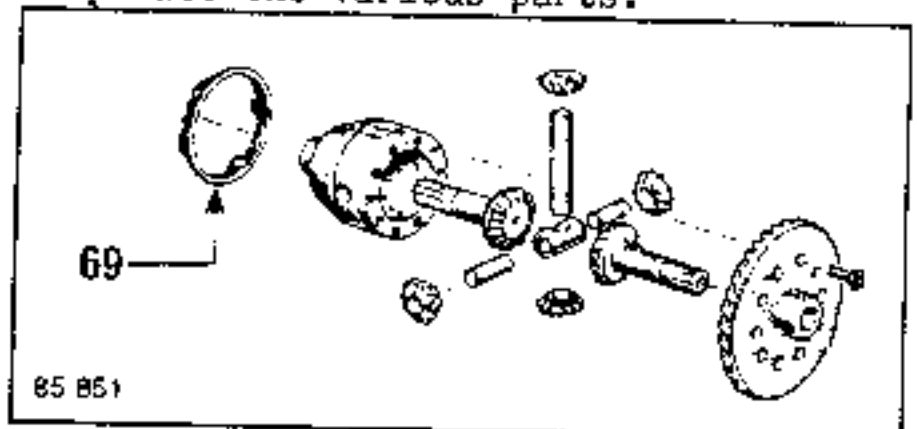

Remove the bolts securing the crown wheel to the housing (these bolts cannot be recovered).

DIFFERENTIAL

Electronic speedometer:

The sensor ring gear cannot be dismantled from the casing.

ALL TYPES

Separate the various parts.

Checking the parts:

Check the condition of:

- the teeth
- the bearing seats
- the washers (on the planet wheels)
- the splines
- the casing.

Remove the nuts from the casings using wrench **B.Vi.807-01**.

Knock out the bearing shells using a piece of tubing with an outer diameter of 71 mm.

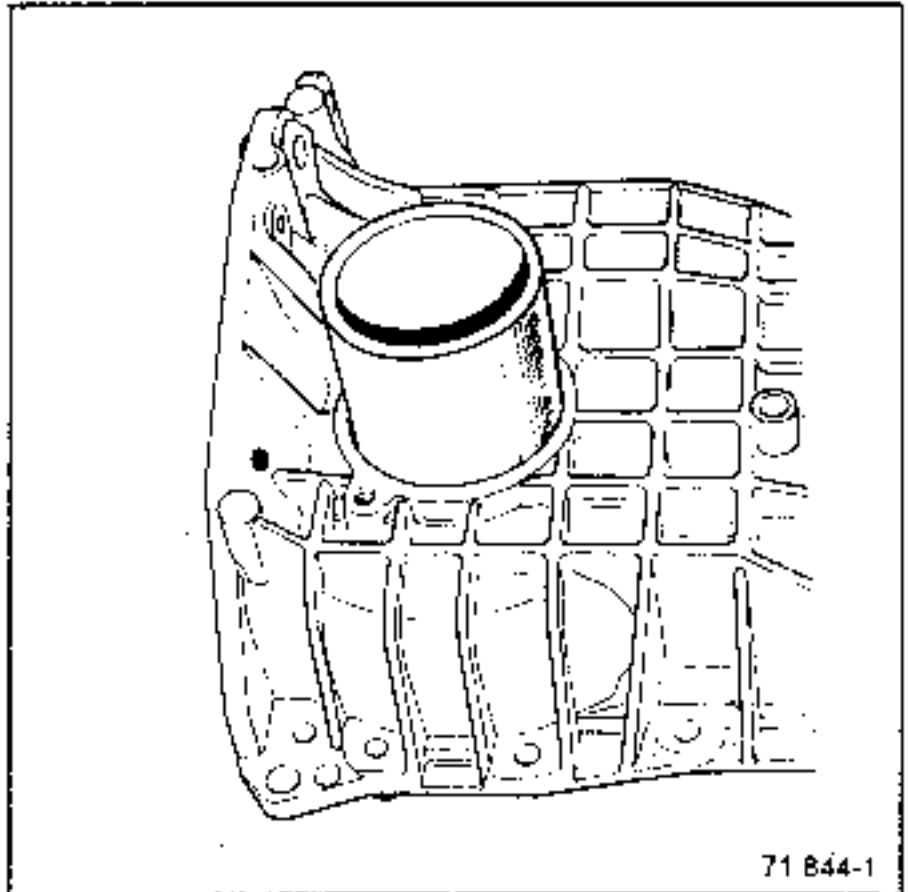

NOTE: The bearing shells and cones must be kept in their pairs.

From the nuts remove:

- O-ring (A);
- deflector (C);
- lip-seal (B).

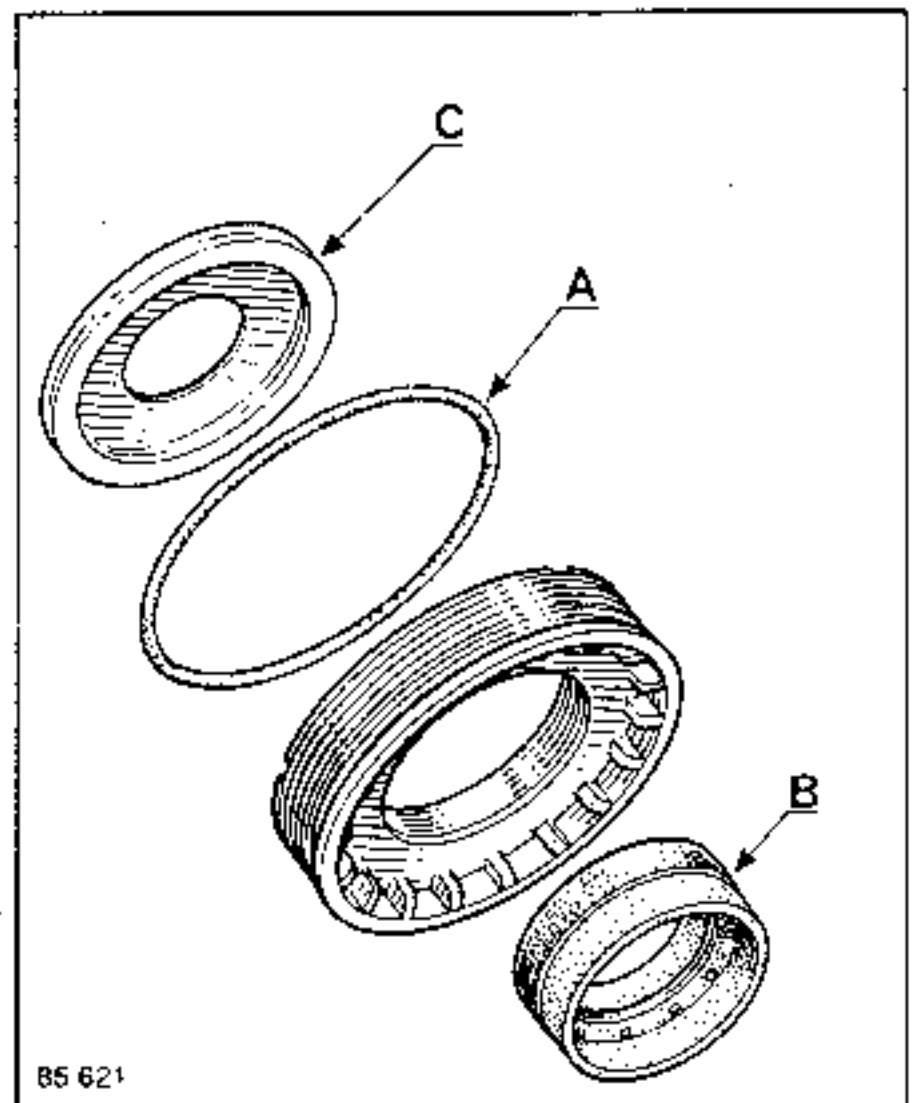
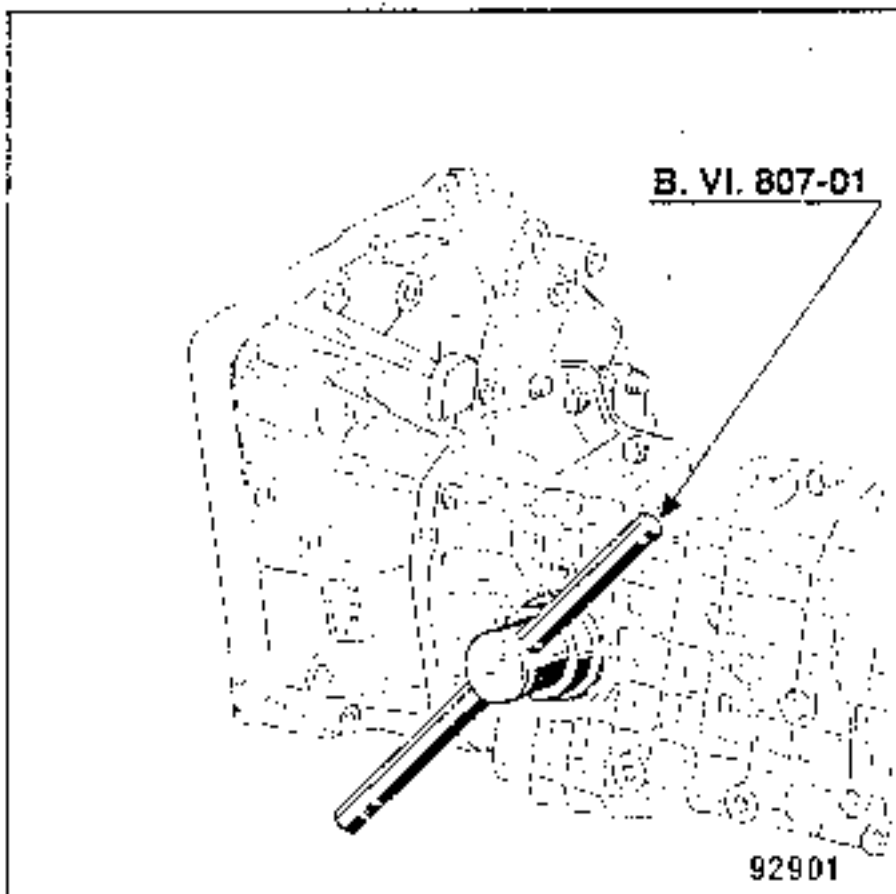

DIFFERENTIAL

Reassembly:

All the parts must be cleaned, checked and lubricated as they are assembled.

The bearings and spring pins must be replaced systematically.

The assembly and adjusting operations must be performed carefully and accurately, in the order given.

In the casing place:

- the bakelite washer with the oil way at the sunwheel end: use the 1.96 mm thick shim. If the mesh clearance between the sunwheel and the planet wheels is too great, use a 2.02 mm thick shim;
- one sunwheel (immersed in the recommended oil);
- the planet wheels and their shims (the locking notch fits in the hole in the casing);
- engage the planet wheel shaft fitted with hub (56) (depending on the vehicle) aligning the hole in the shaft with the hole in the housing;
- fit a spring pin: insert it by approximately 5 mm inside the housing using drift B.Vi.31-01 or B.Vi.39;
- fit the two other planet wheels and insert their shafts (depending on the assembly);
- fit the second sunwheel in the crown wheel;
- assemble the crown wheel on the housing using new bolts which cannot be slackened;
- torque tighten the bolts.

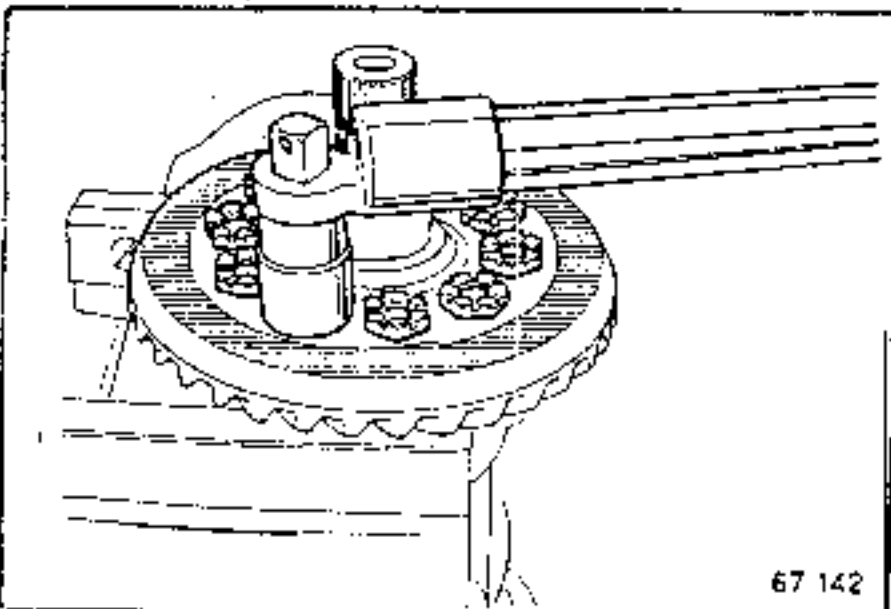

After assembly, the differential may be stiff to rotate.

Collar (69) is refitted using tool B.Vi.883 with the bearing not fitted and on the press.

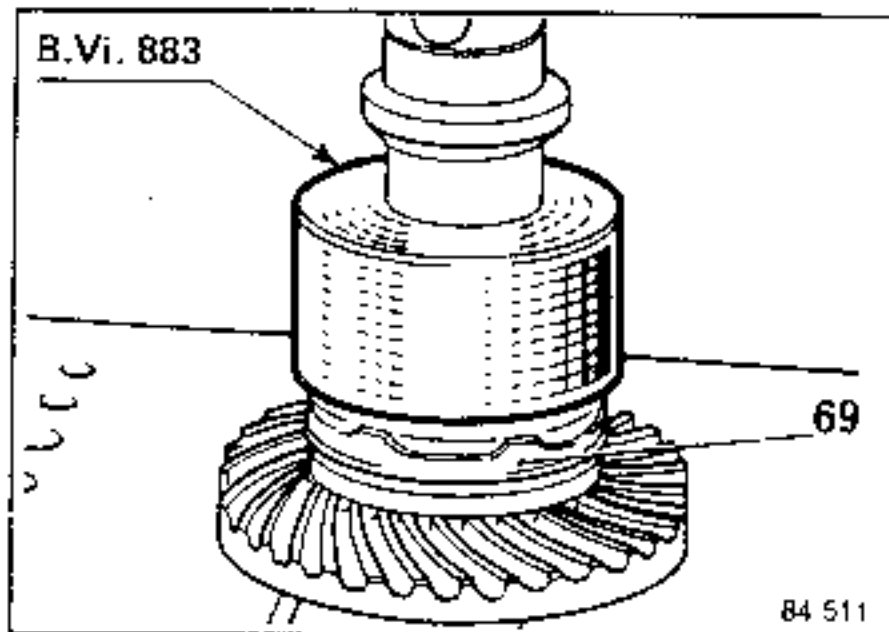

Check that ends (A) of the collar (69) are positioned correctly in the differential casing groove.

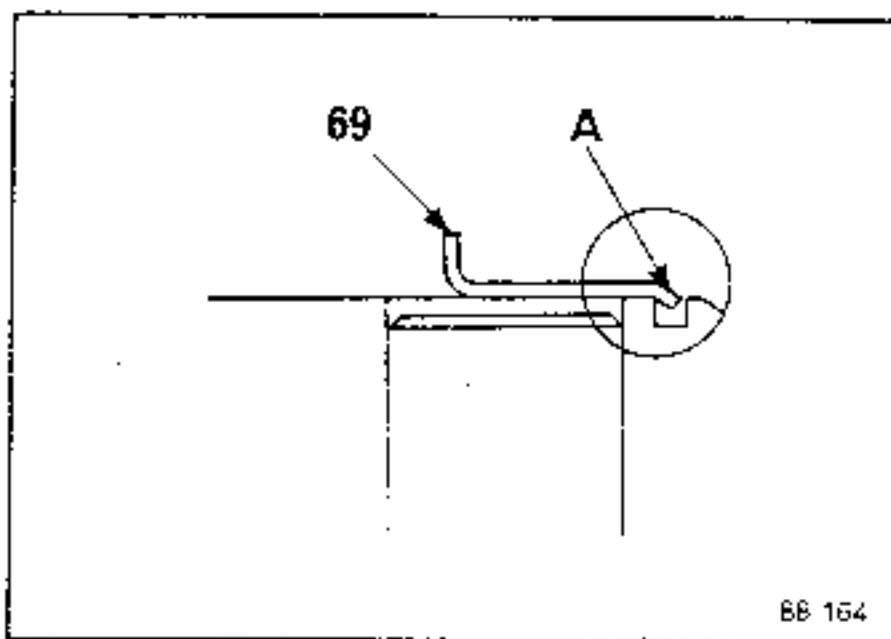

If they are not, lower the collar slightly using a bronze drift.

Accentuate the curve of the end at (A) very slightly if necessary.

Differential with four planet wheels and no rollpins

Proceed in the same way.

Do not fit washers or shims to the planet wheels.

DIFFERENTIAL

Reassembly:

Fit the bearings on the press.

The diameter of the bearing at the crown wheel end is smaller than that at the housing end.

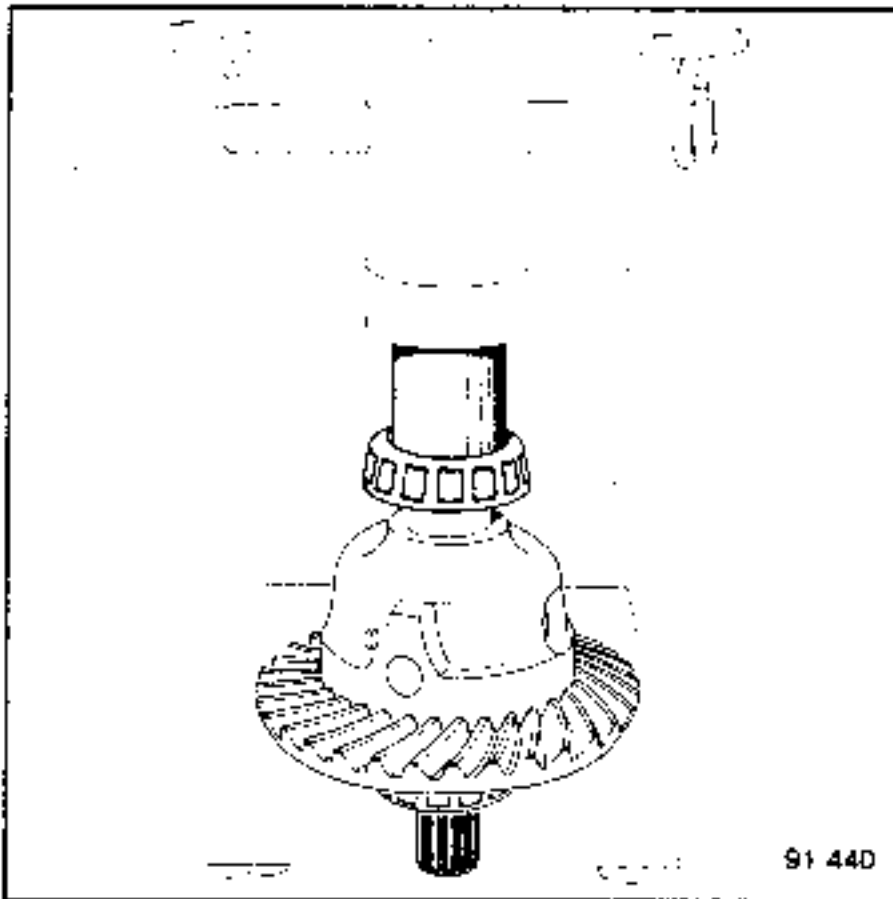

Fit the bearing outer track rings so that they are slightly recessed in relation to the inner face of the casings and the adjusting nuts (without seals), taking care to tighten the nut more at the casing end.

Adjust the differential bearing pre-load.

DIFFERENTIAL

Bearing pre-load

(Direction for fitting the crown wheel)

NG All types (except NG5)

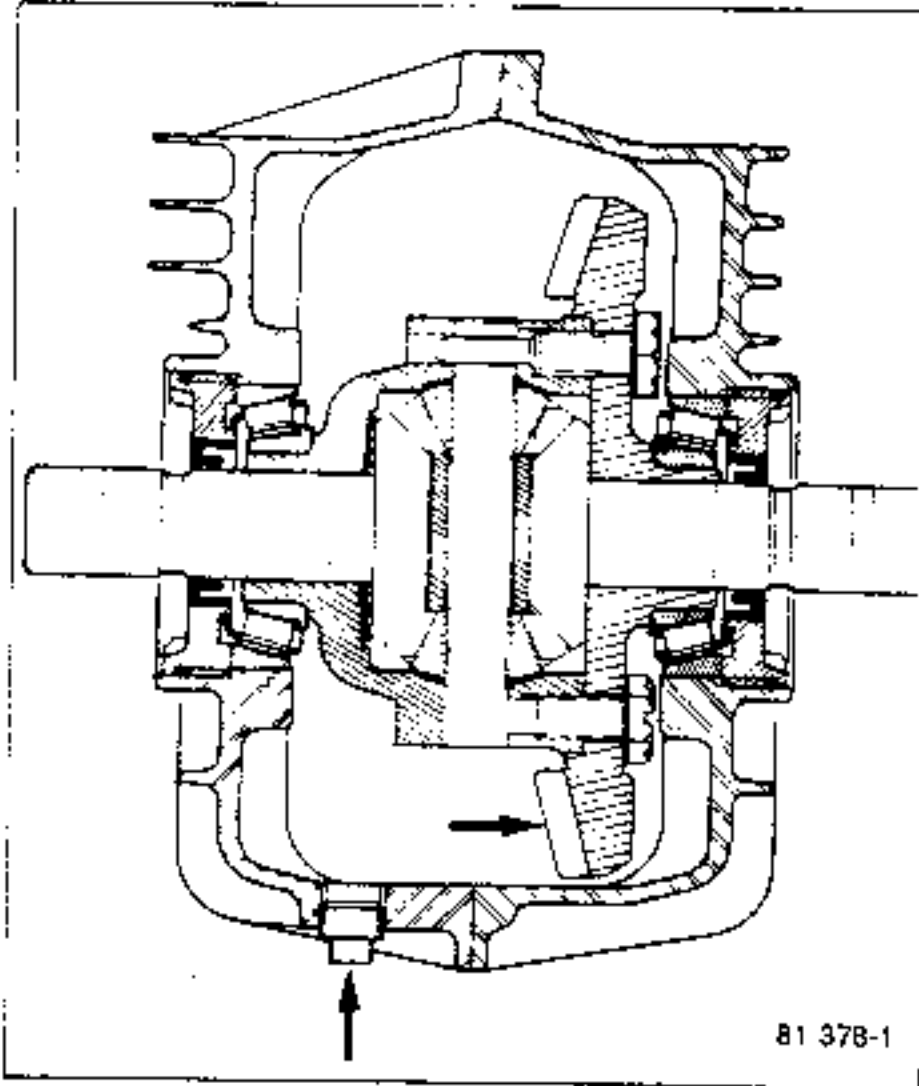

End opposite drain plug

NG5

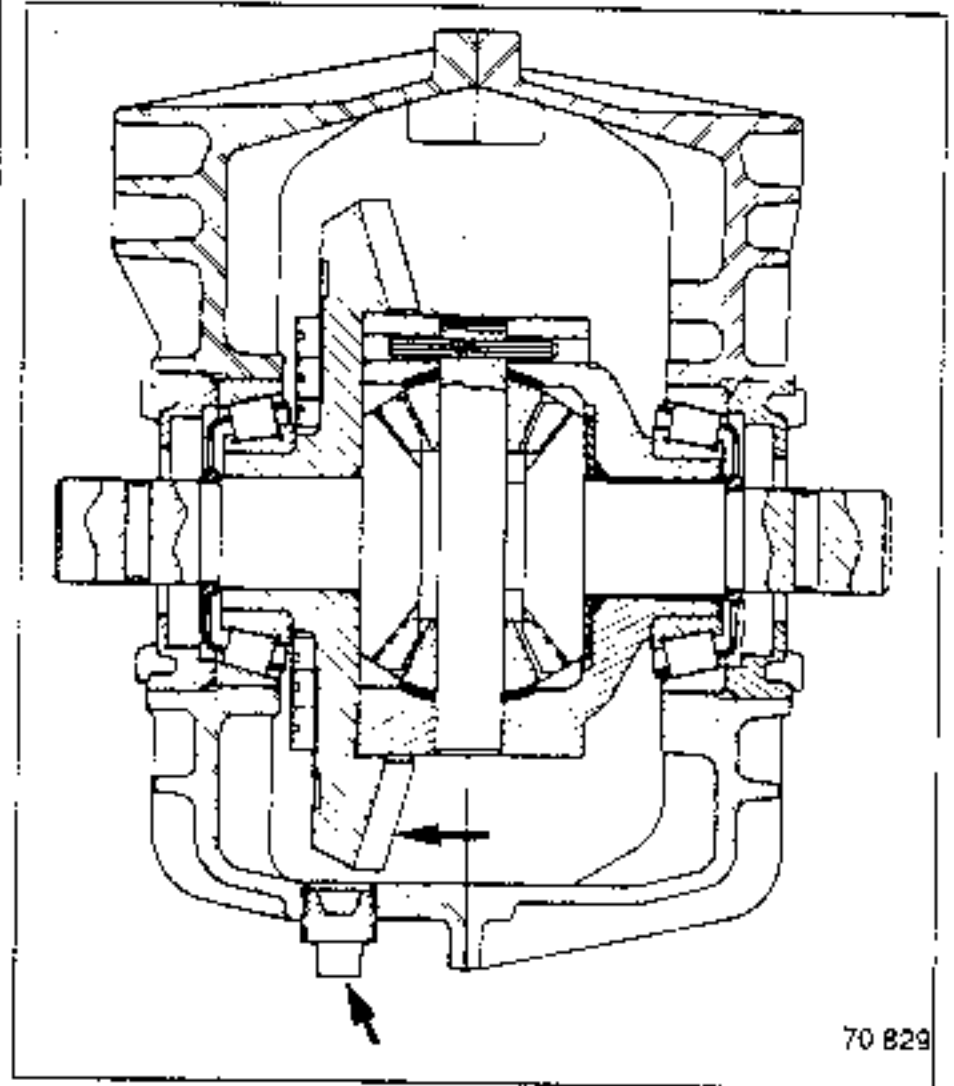

Drain plug end

DIFFERENTIAL

Bearing pre-load

Once the outer tracks of the differential bearings are fitted, fit the differential in the casings without the final drive pinion and torque tighten the bolts on the casings in the order shown.

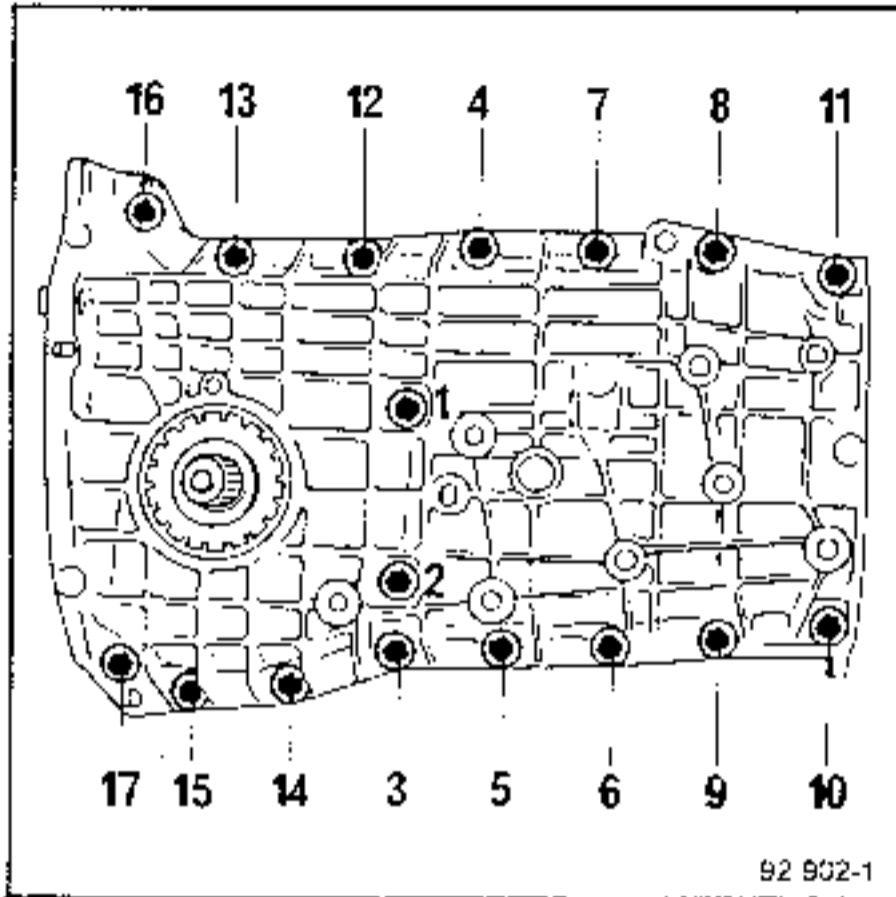

Checking the pre-load

Turn the differential several turns to centre the bearings.

Wind a piece of string around the differential housing.

Pull steadily on the string using a spring balance.

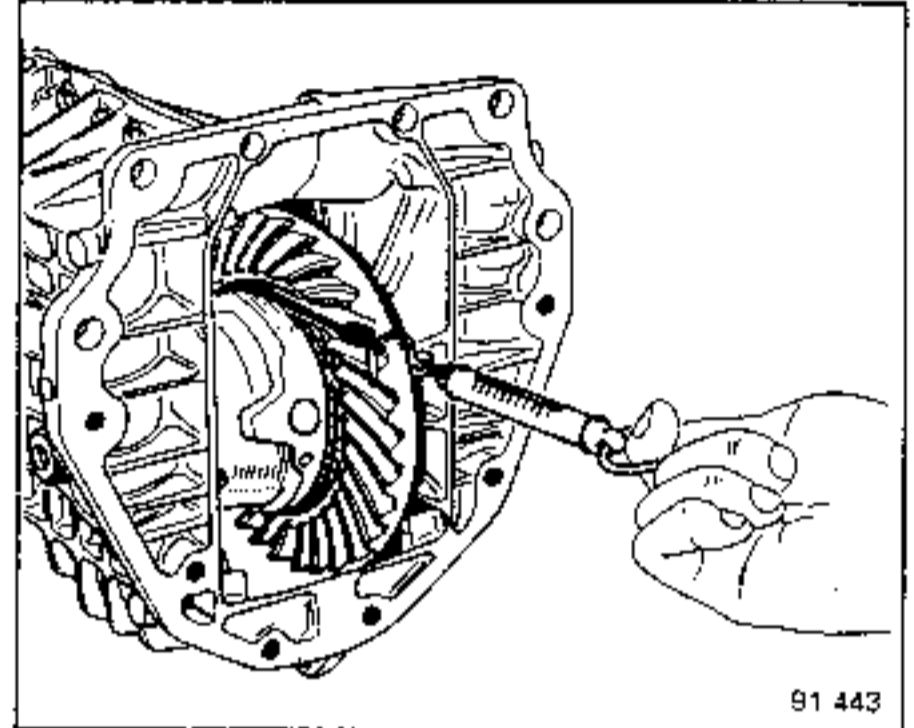

The differential should rotate under a load of between 4 and 6 daN. This load is the amount required to turn the differential continuously.

If the adjustment is not correct, tighten or slacken one ring nut slightly and re-check the pre-load.

In both cases, after the pre-load has been adjusted, mark the position of the ring nuts in relation to the casing.

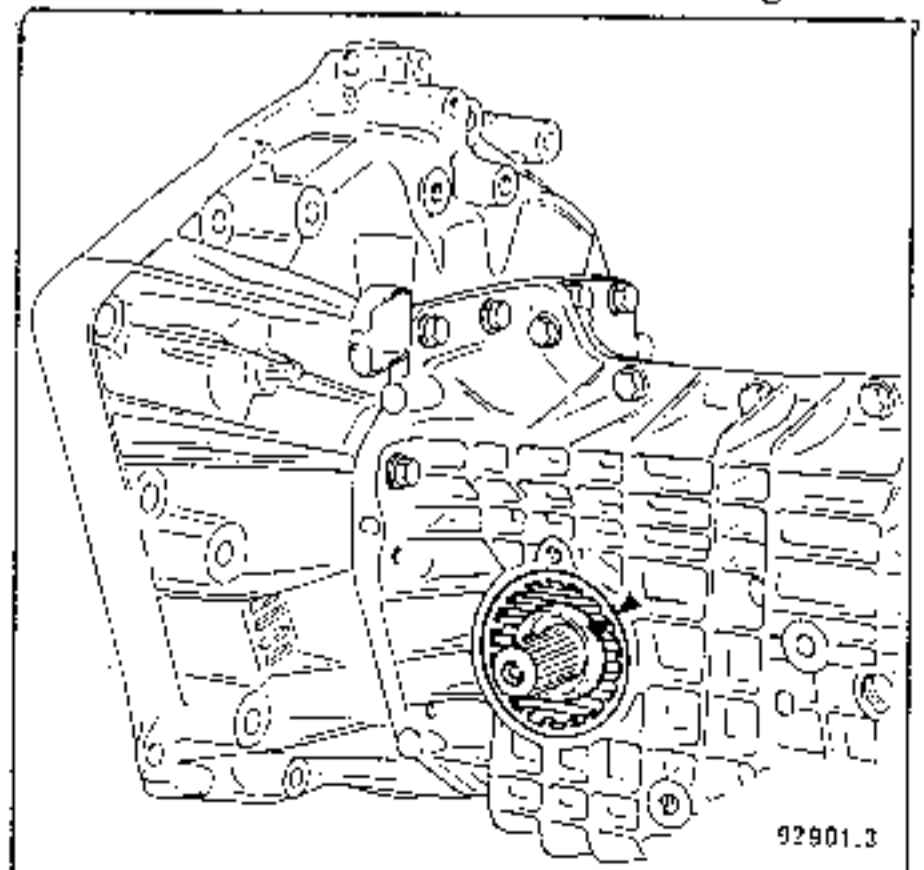

The pre-load is adjusted by tightening or slackening the nuts using tool B.Vi.807-01.

NOTE: Do not fit new lip-seals to the adjusting nuts since there is a risk of their being damaged by the sunwheels when the gearbox is opened again.

Turn the differential and tighten the nuts, taking care to tighten the nut at the casing end slightly more than the one at the crown wheel end so that a backlash which is greater than normal is obtained on reassembly.

Two possible cases may arise:

1. Re-used bearings

When the differential turns freely and without play, stop tightening the nuts and the pre-load is adjusted.

2. New bearings

When the differential turns freely and without play, tighten the nut at the casing end (it will be slightly hard to turn) then check the pre-load.

INTERNAL CONTROLS

EXPLODED VIEW

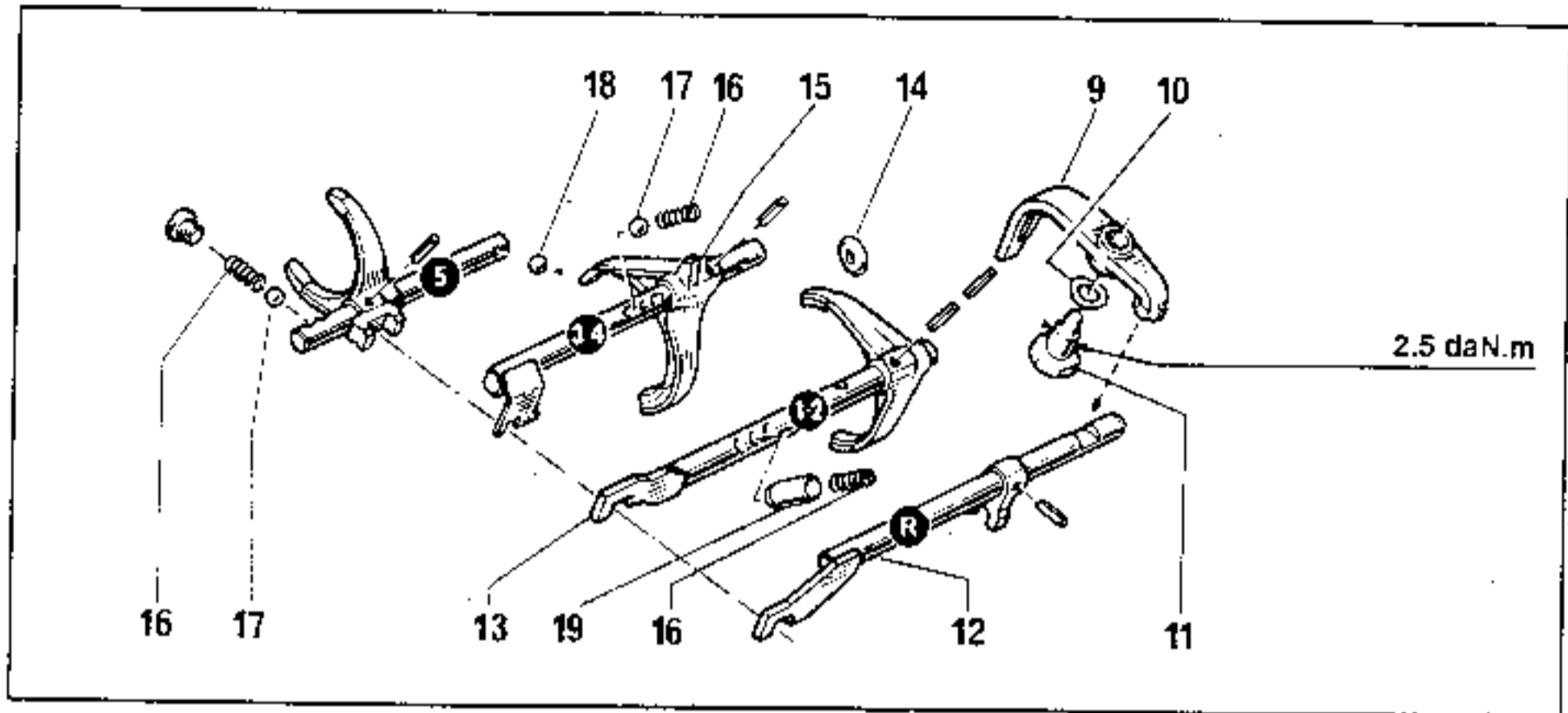

This operation is performed after the casings have been separated.

TIGHTENING TORQUES (in daNm)	
Reverse gear lever bolt	2.5

CONSUMABLES
Loctite FRENLOC: - Reverse gear lever bolt

DISMANTLING

- Remove the reversing lights switch.
- Place the shafts in the neutral position.
- Remove the 5th speed shaft-fork assembly and locking ball 18.

- Select 1st gear.
- Remove the reverse gear switch.

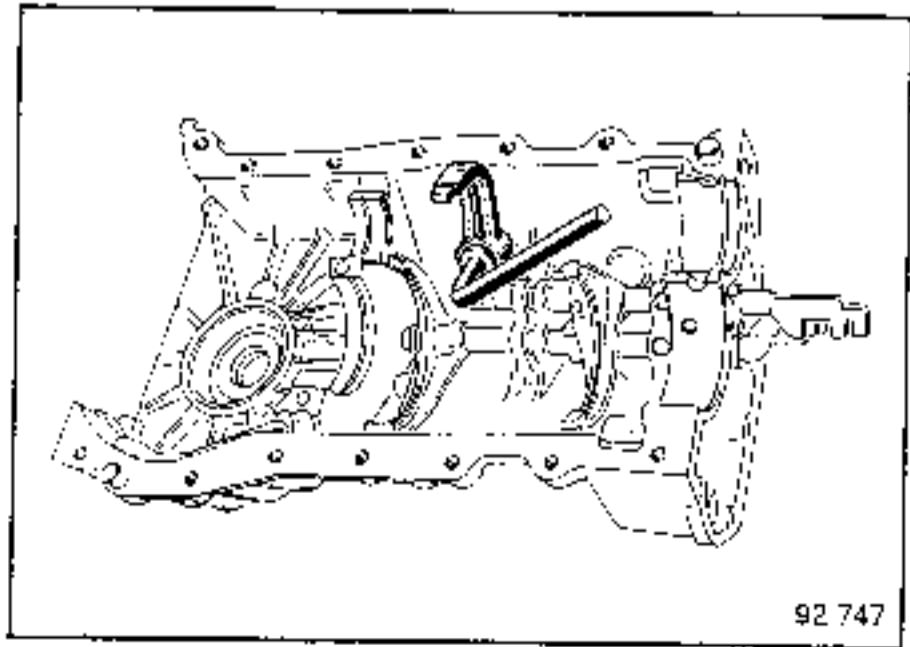
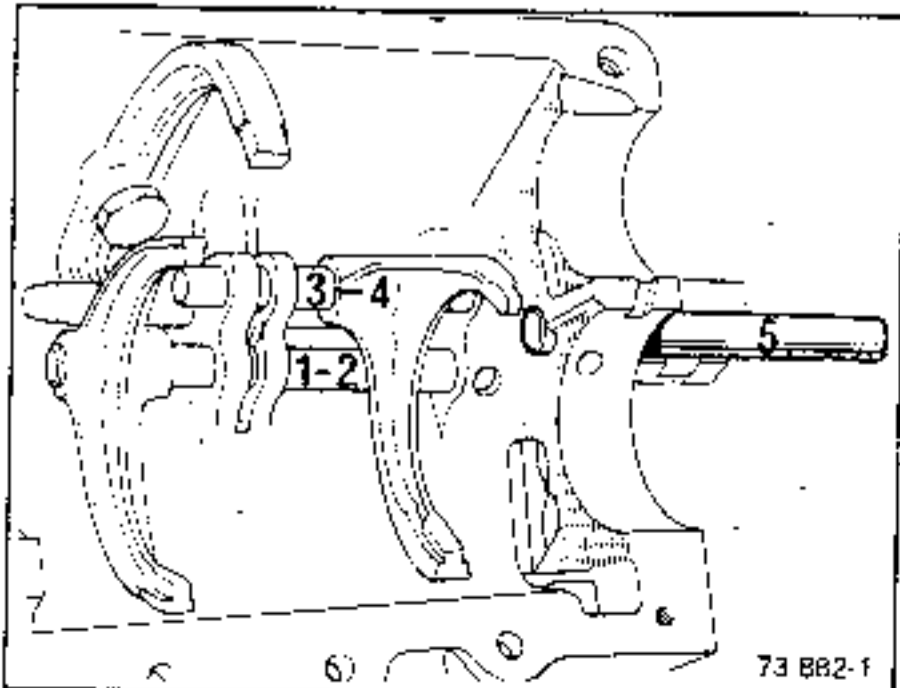

Return to neutral and push the reverse gear outwards.

INTERNAL CONTROLS

Knock out the spring pins from the 1st/2nd and 3rd/4th speed forks using drift B.Vi.31-01 and a 4 mm pin drift.

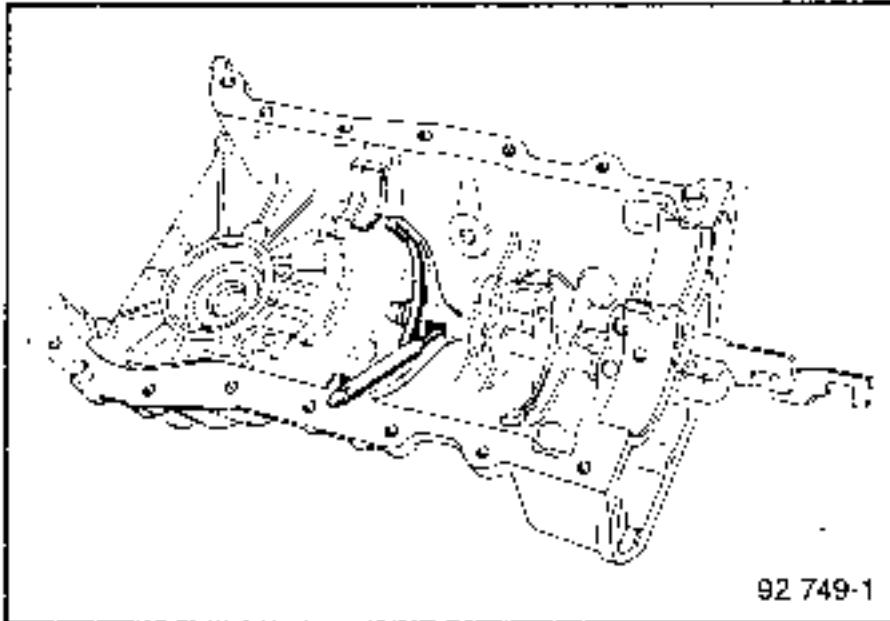

Place the reverse gear in neutral again.

NG - All types (except NG7)

Remove:

- the 3rd/4th speed shaft and fork;
- the locking disc;
- the 1st/2nd speed shaft and fork; using a 2 mm pin drift, compress the locking plunger spring so that the assembly can overcome the notch for the shaft locking ball.

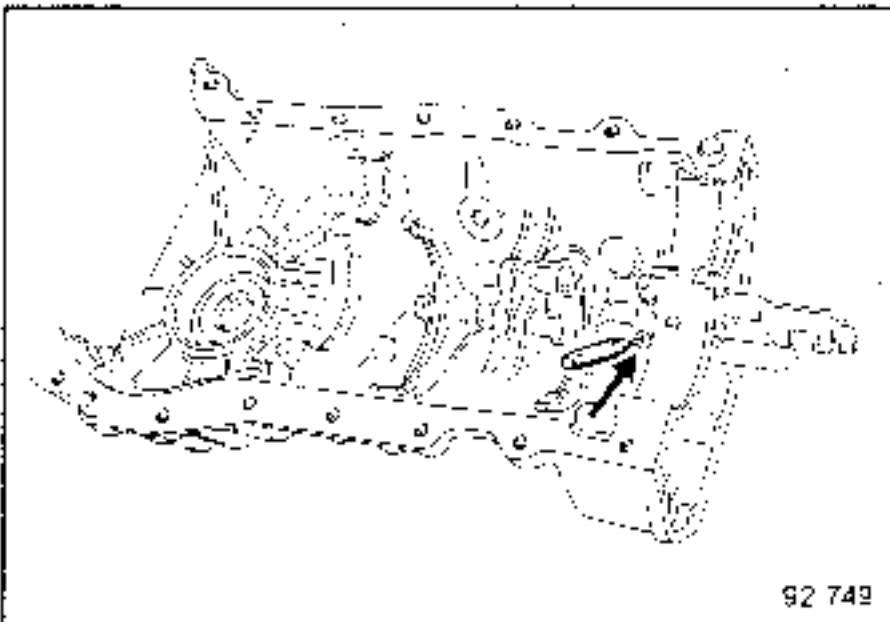

Recover the ball, plunger and springs.

NG7: Special point

Remove the 1st/2nd speed shaft before the 3rd/4th speed shaft.

All types

Knock out the pin from the fork on the reverse gear.

Remove the shaft and fork.

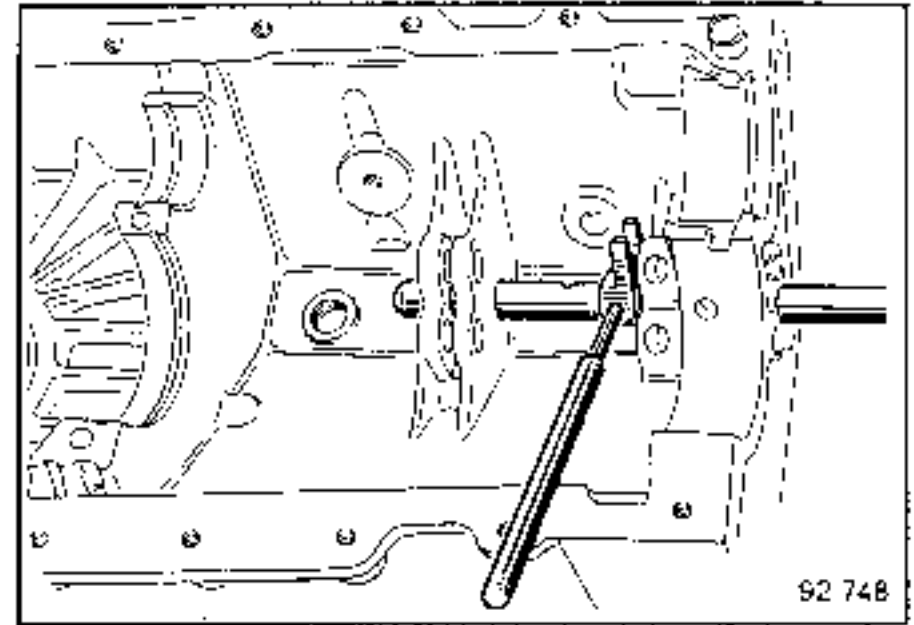

NOTE: As the rollpin is against the casing, turn the shaft so that it can be removed completely with pliers.

The shafts must not be deformed in any way, and there must be no signs of wear on the seat of the locking balls. In addition, they should slide freely in their journals without excessive play.

Checking the forks:

The surface of the forks in contact with the slide gears must not be deformed or worn.

INTERNAL CONTROLS

Reassembly:

Replace all the spring pins, making sure they are fitted in the correct direction:

- the groove on the spring pins must be along the centreline of the shafts.

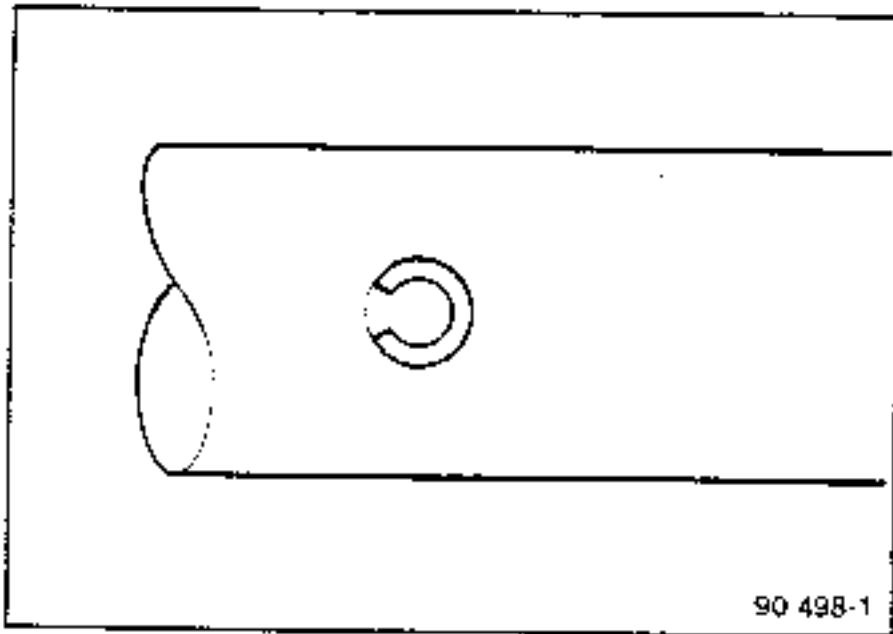

1st type:

The 1st/2nd and 3rd/4th shaft locking balls and springs are all the same.

2nd type: 2nd speed synchro assistance

The ball is replaced by a plunger and the 1st/2nd and 3rd/4th speed locking springs are different.

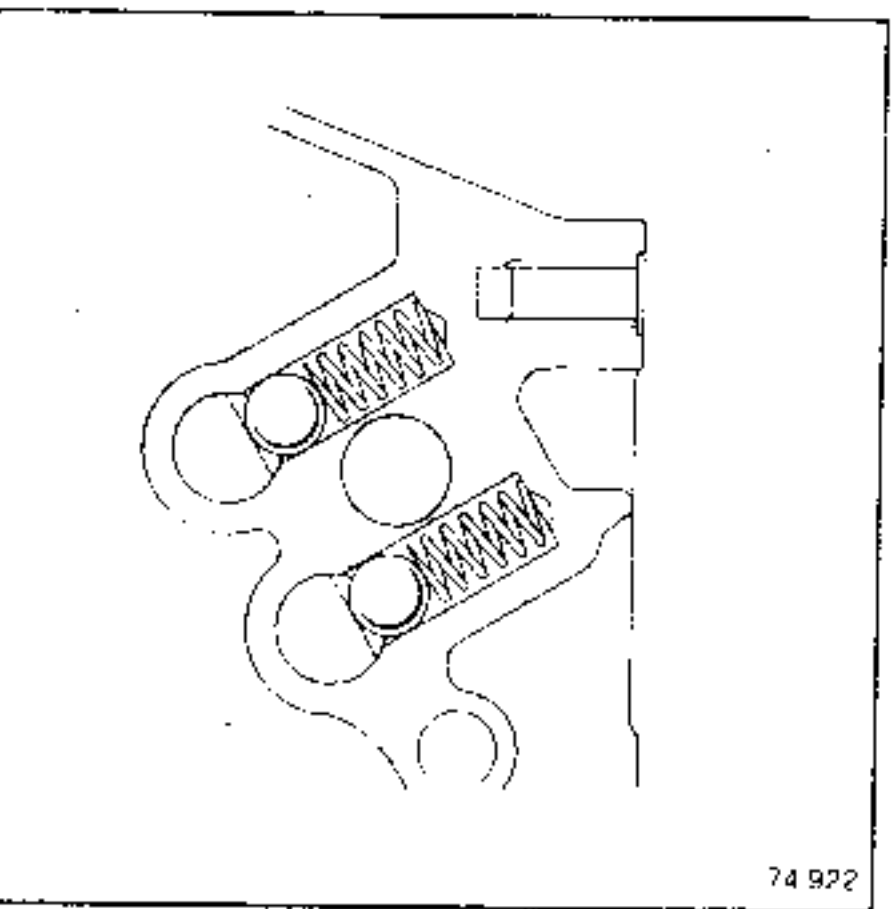

Fit in order:

- the reverse gear shaft and its fork;
- the spring and ball or plunger for the 1st/2nd speed shaft;
- engage the shaft and fit the fork.

Using a hook, align the holes in the fork with the hole in the shaft. Ensure that the fork is fitted the correct way, with the mounting holes facing the rear casing.

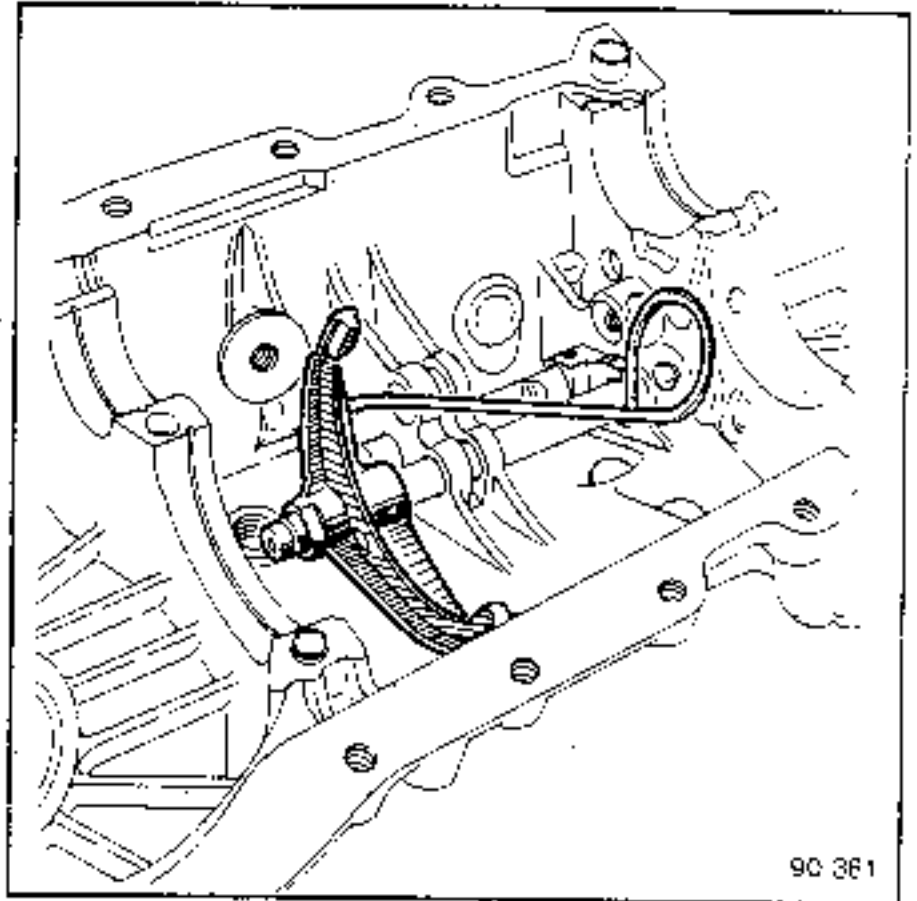

Fit the locking disc between the shafts.

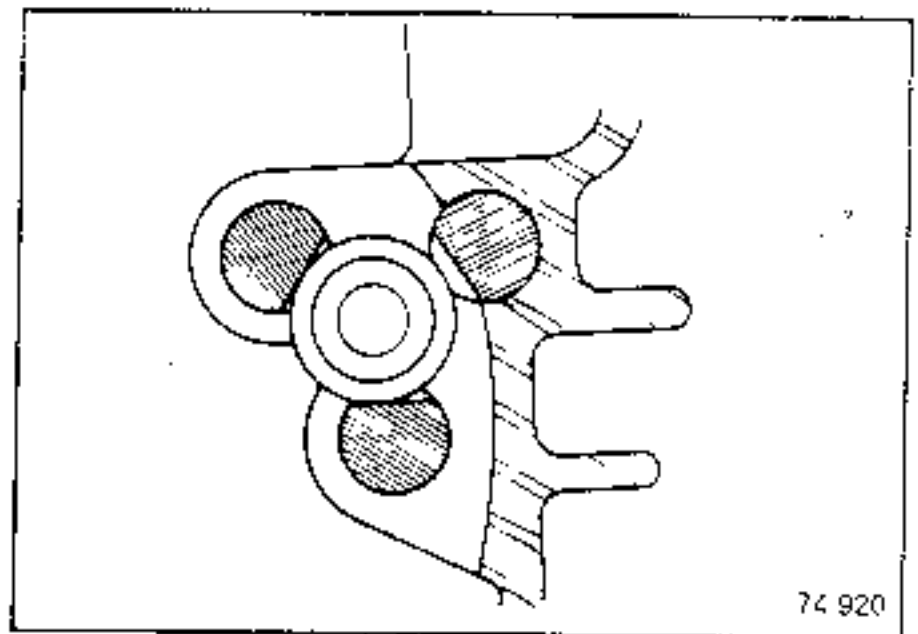

INTERNAL CONTROLS

Fit in place the 3rd/4th speed shaft locking ball and spring.

Engage the shaft by fitting the spring and rollpin.

NG7: Special point

Fit in place the 3rd/4th speed shaft and fork before the 1st/2nd speed shaft and fork.

All types:

Fit the reverse gear lever, engaging its end in the notch in the shaft.

Coat the threads of the reverse gear lever with **Loctite FRENLOC** and torque tighten it.

2nd speed synchro assistance:

After fitting the rollpin, make sure that the fork slides on its shaft.

Fit:

- the shafts in the neutral position;
- the interlocking ball (18) in its location;
- the 5th speed shaft-fork assembly (A).

Check the operation:

- engage 4th gear;
- push axially on the 5th speed shaft, it should be locked in position.

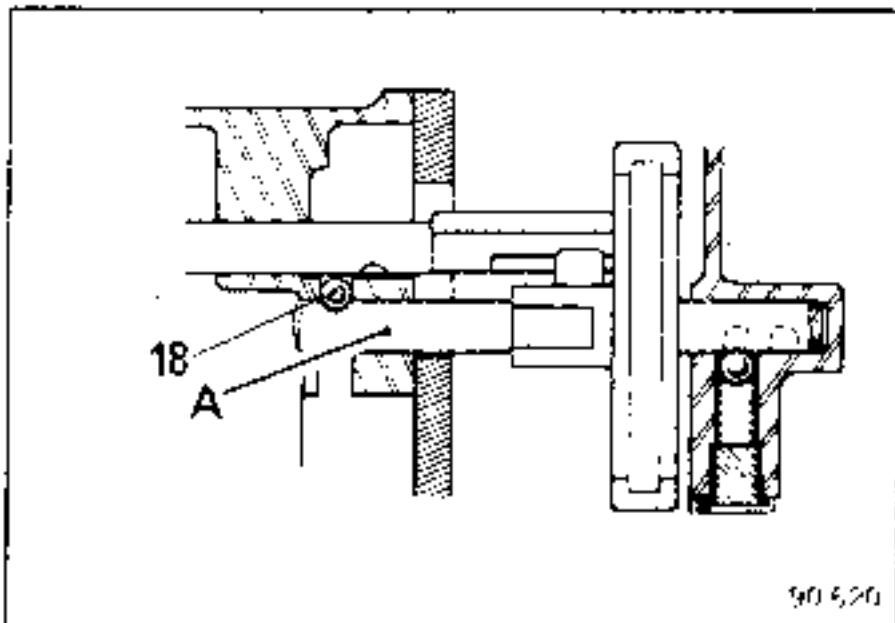

REAR CASING

EXPLODED VIEWS

NG1 - NG3

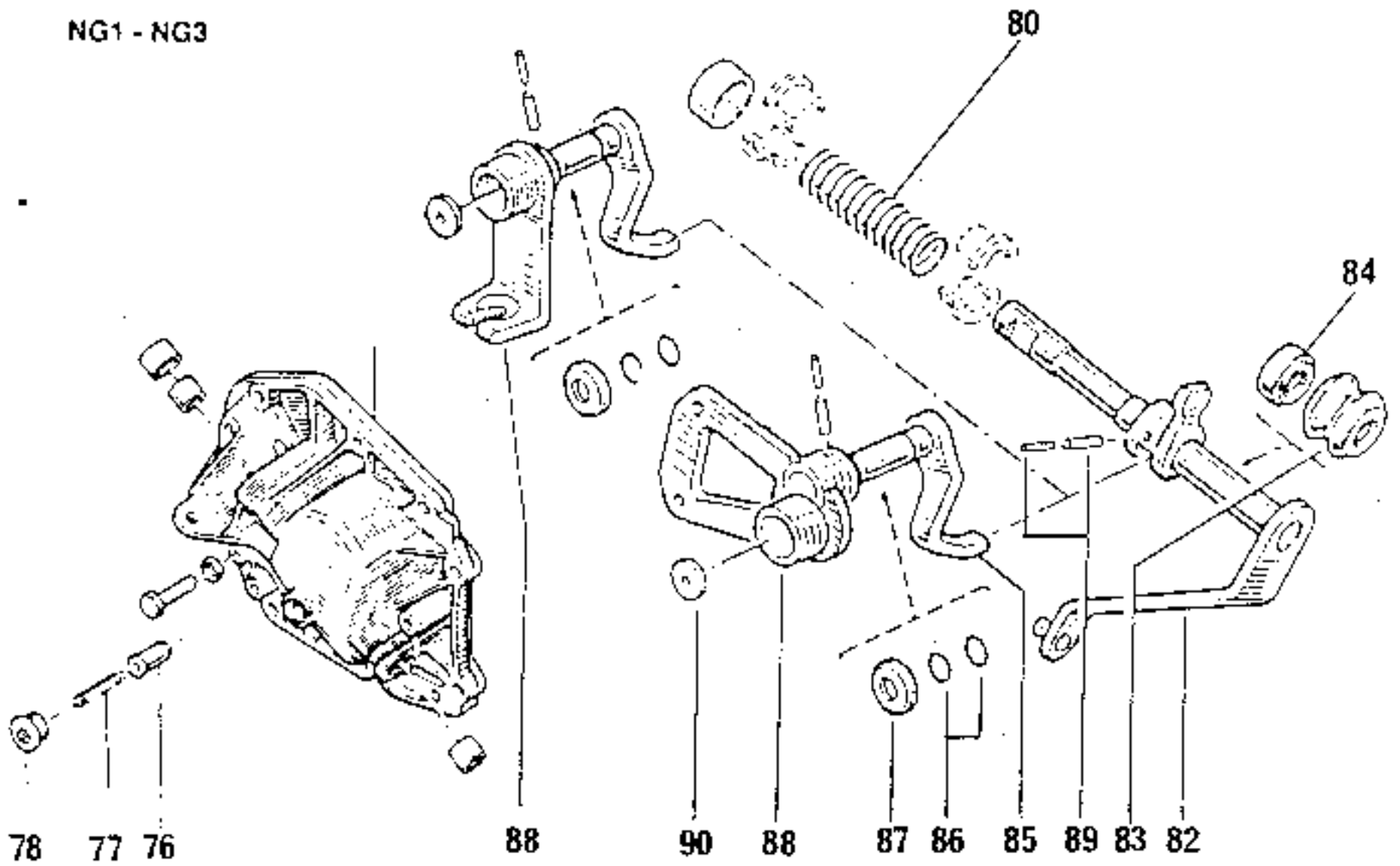

NG5

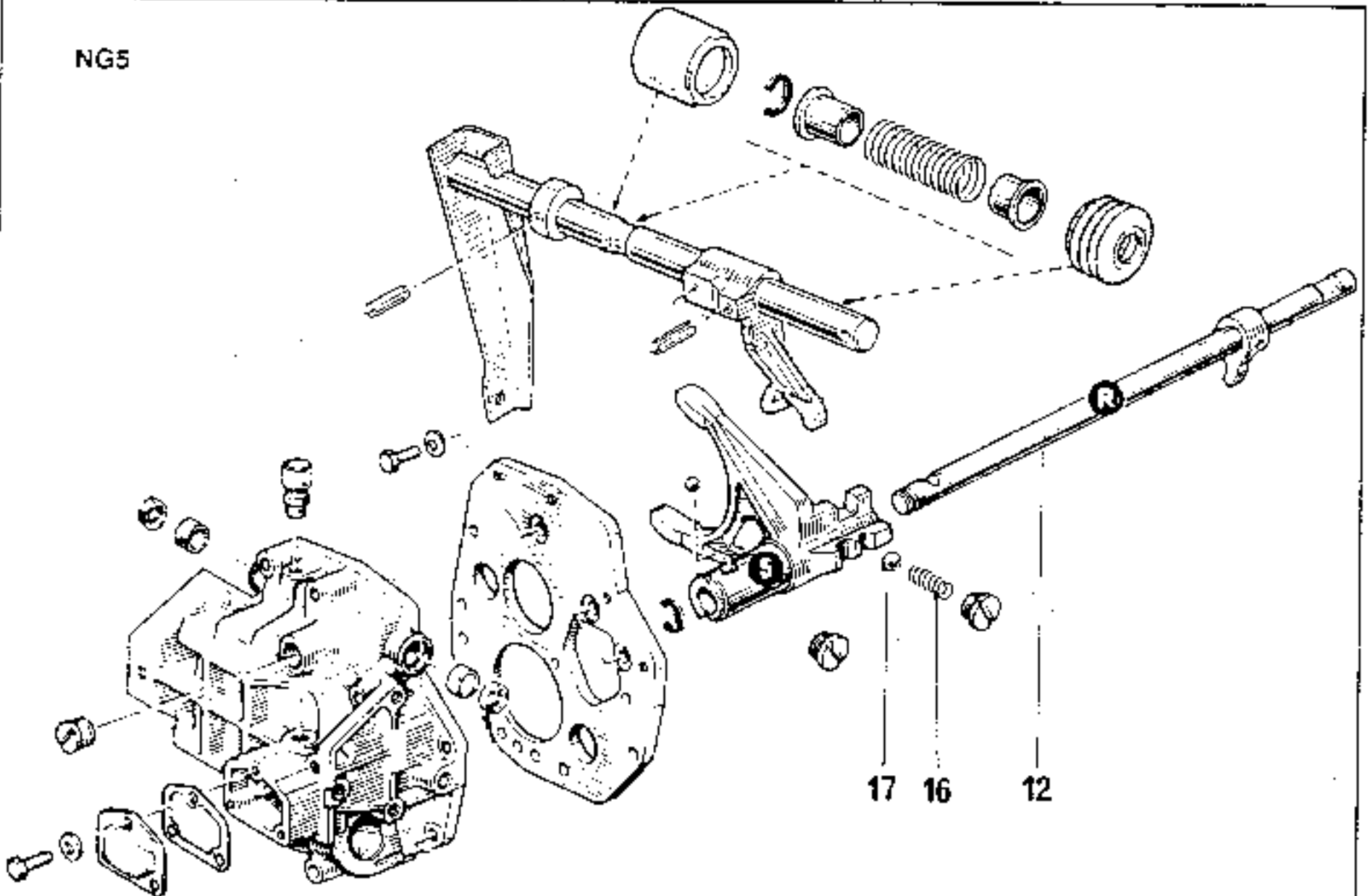

REAR CASING

NG1- NG3 (1st type)

Remove the reverse gear detent plunger (P).

Remove the circlip and dust protector (87) from the selector lever finger shaft (85).

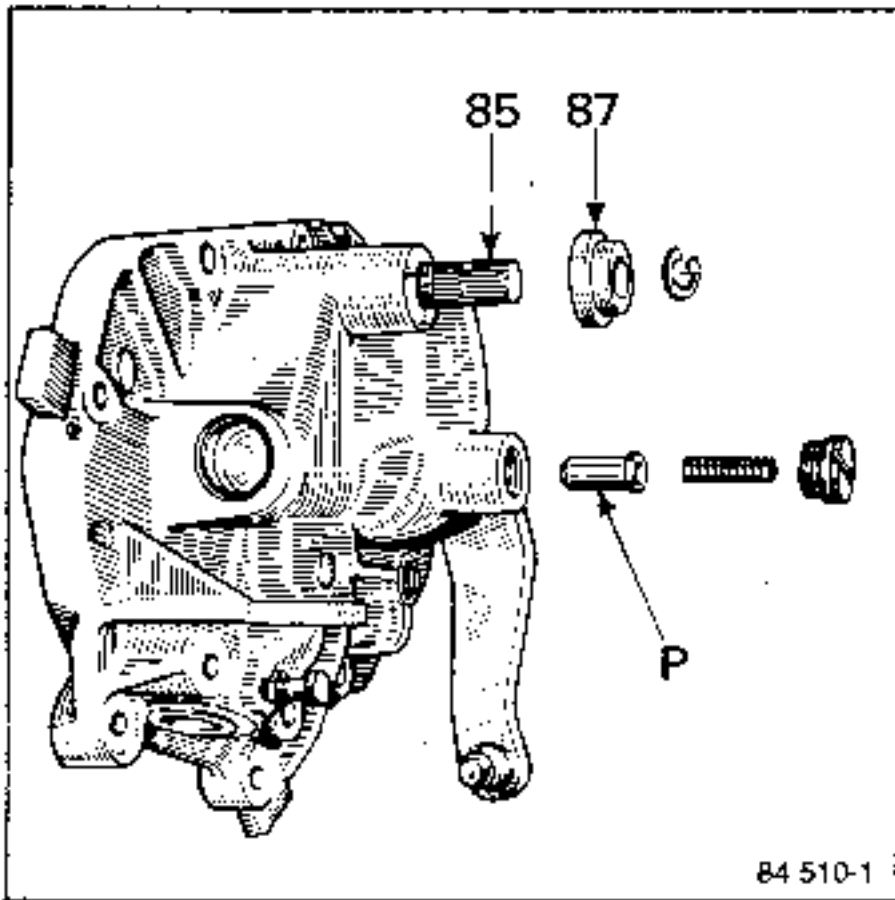

NG3 (2nd type) - NG9 - NG7

Remove the rollpin from the ball joint cover mounting lever sleeve then remove the sleeve.

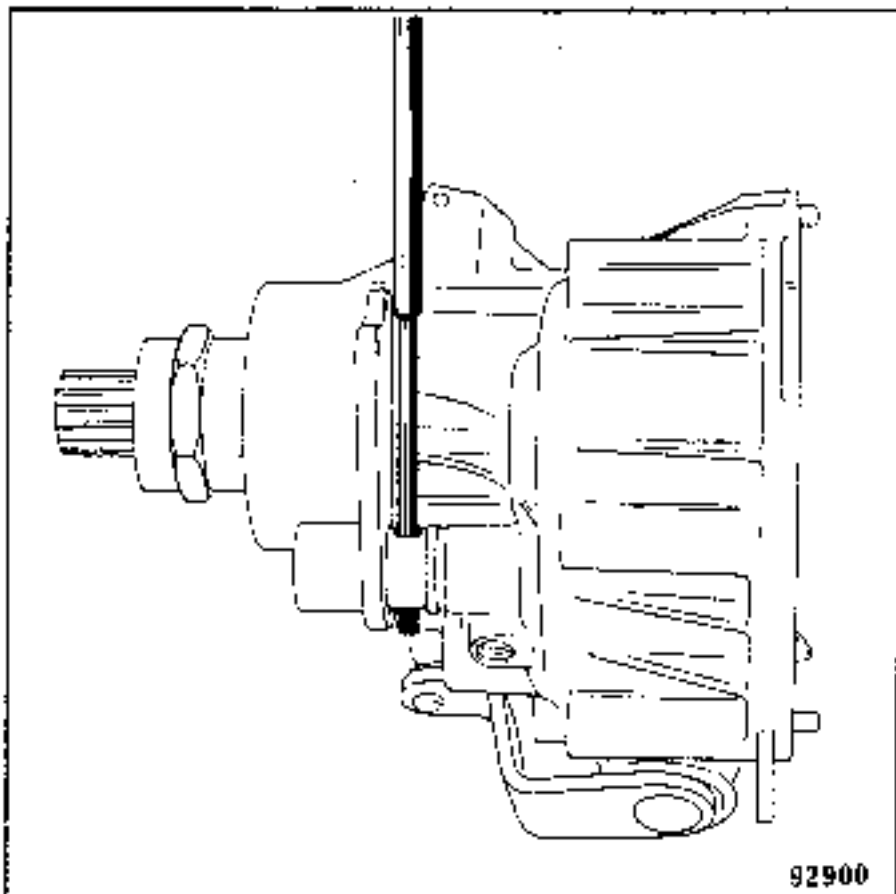

Fit tool Rou.604-01 to the flange and remove bolt (102).

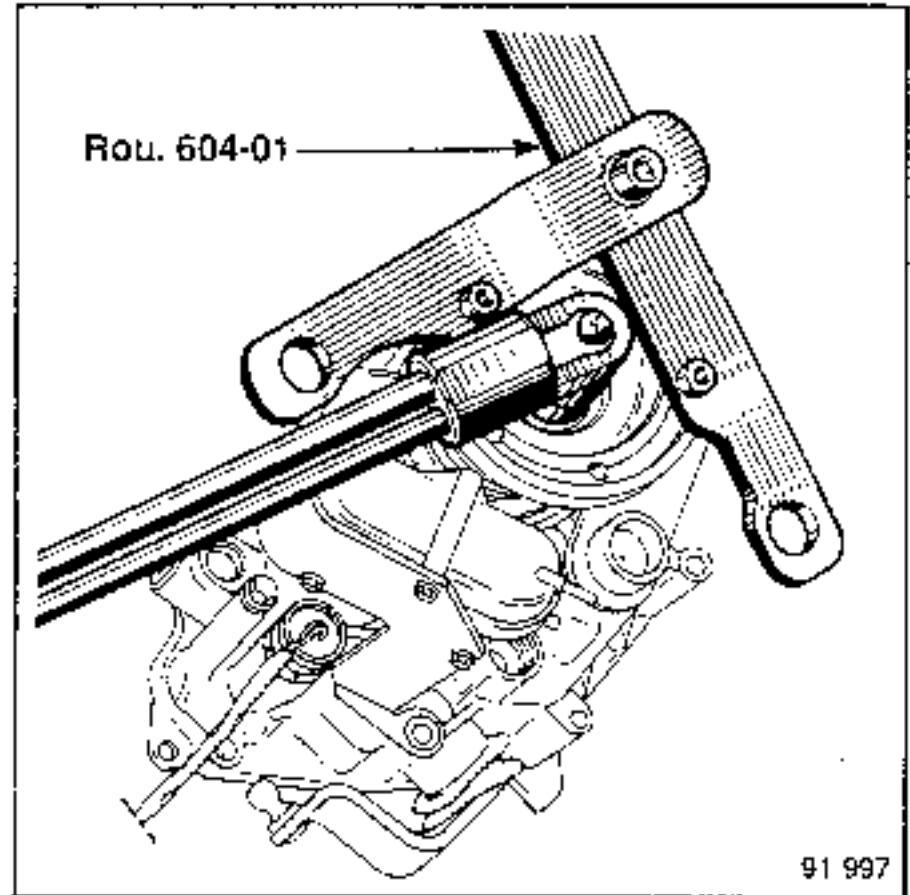

NOTE: Bolt (102) must be replaced each time it is dismantled.

Using extractor FACOM U32-102 or the like, extract flange (100).

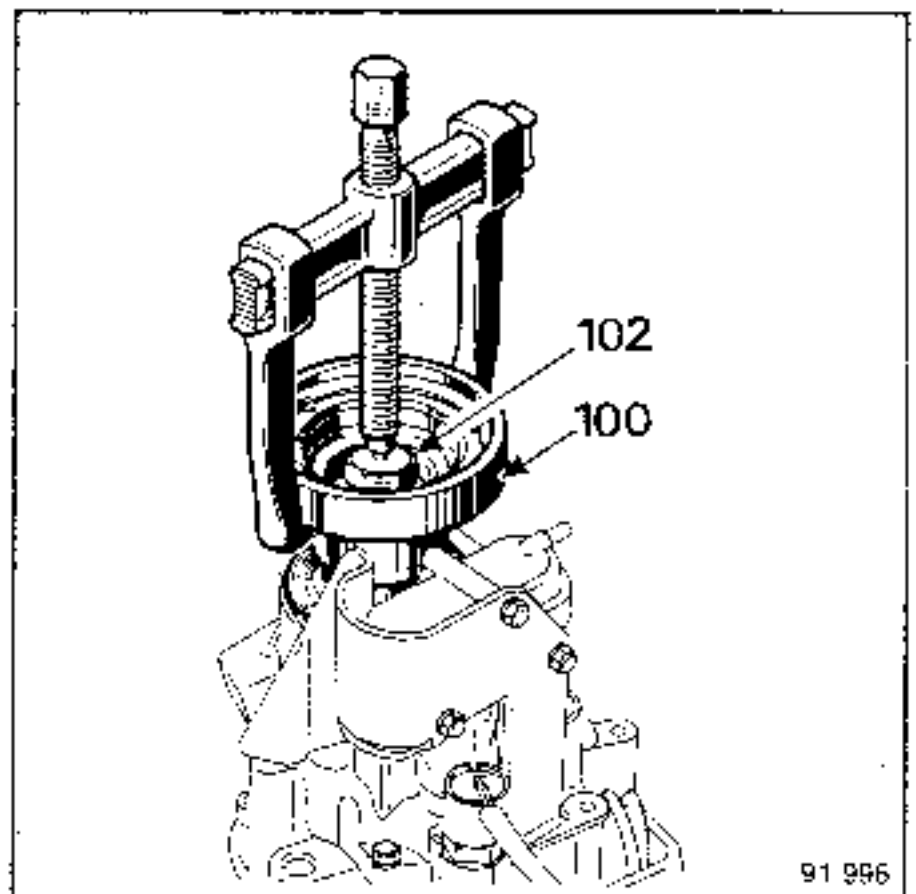

REAR CASING

Disengage protector (109).

Remove pin (107) and shaft (106).

Uncouple the vacuum capsule and remove it.

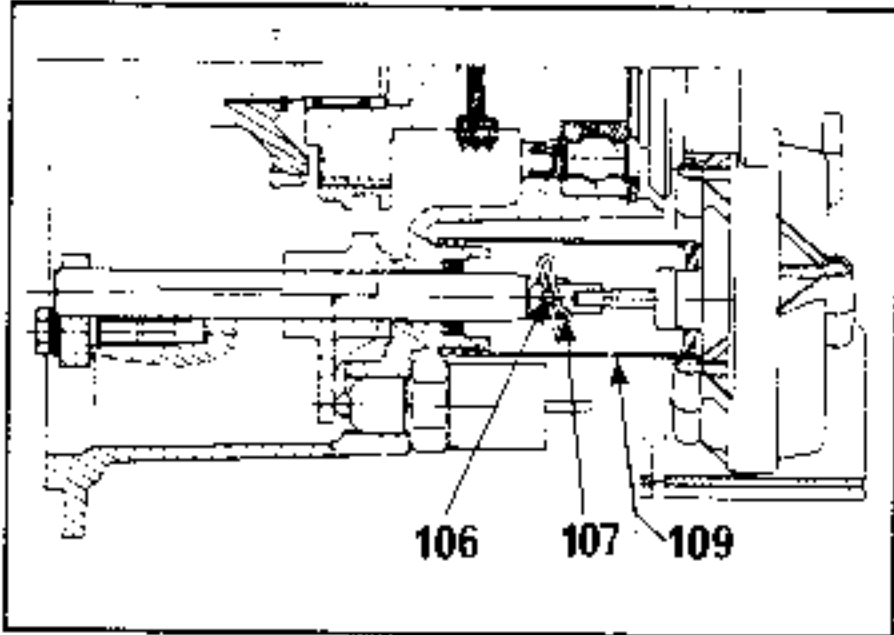

Take the rollpin out of the selector finger using B.Vi.31-01.

Remove the dog clutch shaft journal.

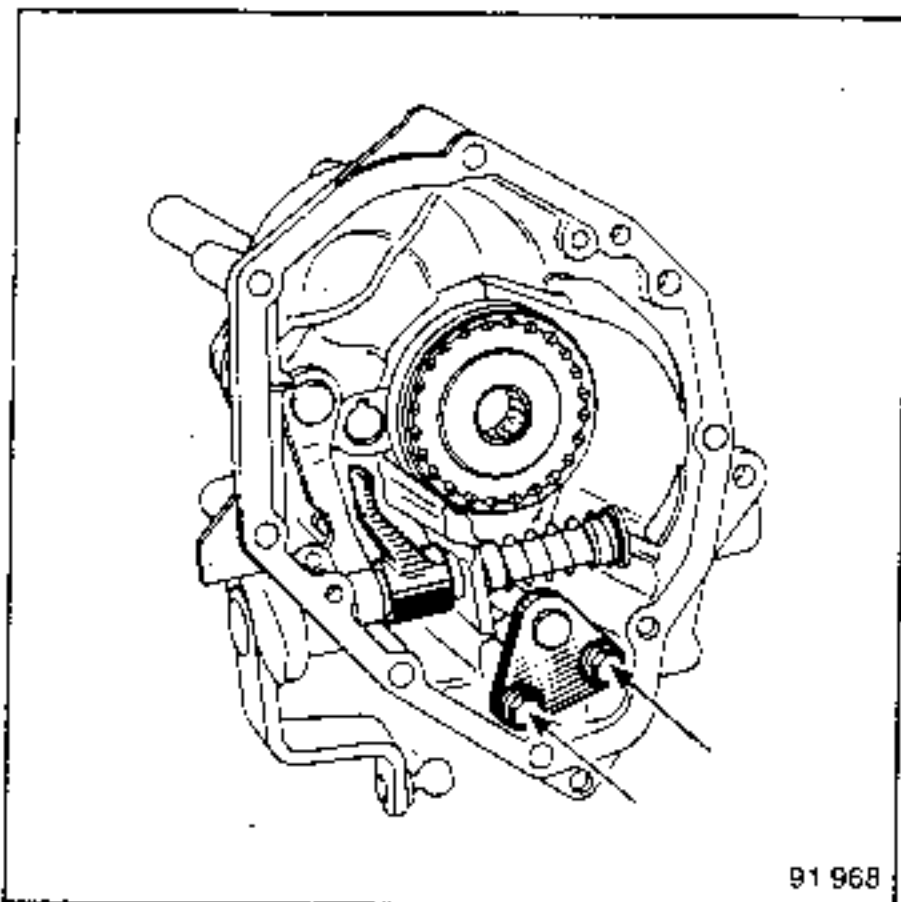

91 968

All types:

Using tool B.Vi.747 compress spring (80) and remove the half shells (79).

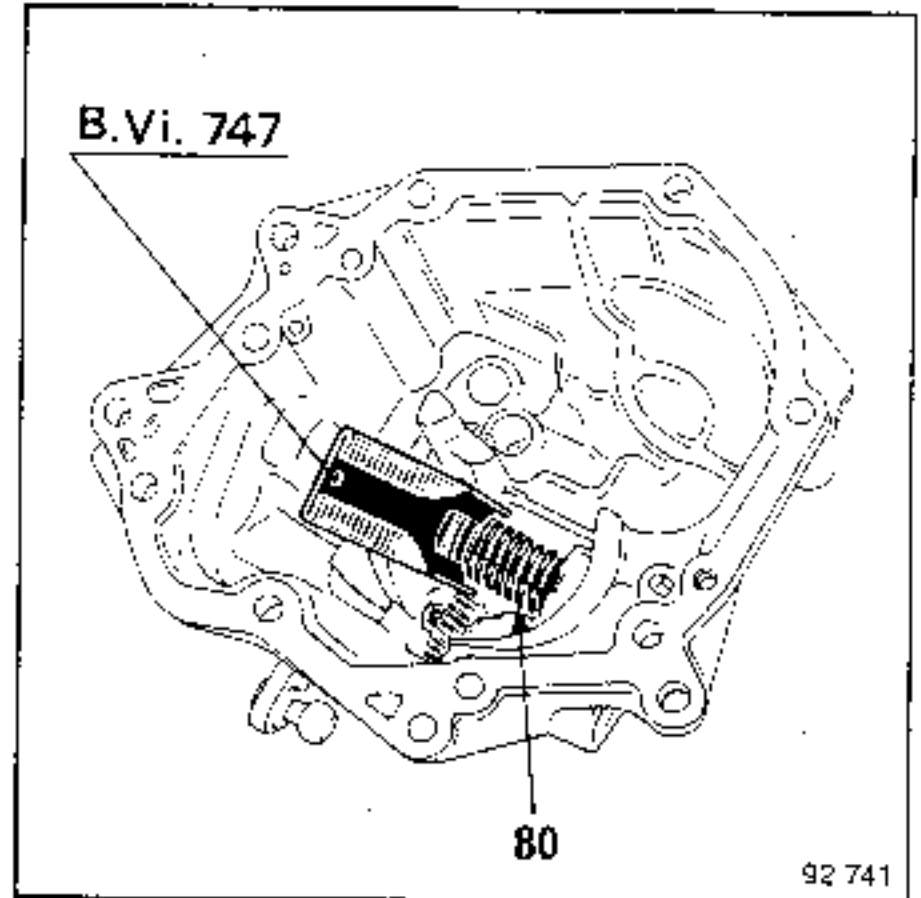

Pull the shaft outwards and recover the selector finger and spring.

Take out selector lever (85) and the shaft fitted with its O-rings (86).

REAR CASING

Mark the slide gear in relation to the hub and remove the slide gear/fork/dog shaft assembly.

On the press, knock the output shaft into the casing.

Remove circlip (99).

Take out bearing (98) and lip-seal (97) on the press.

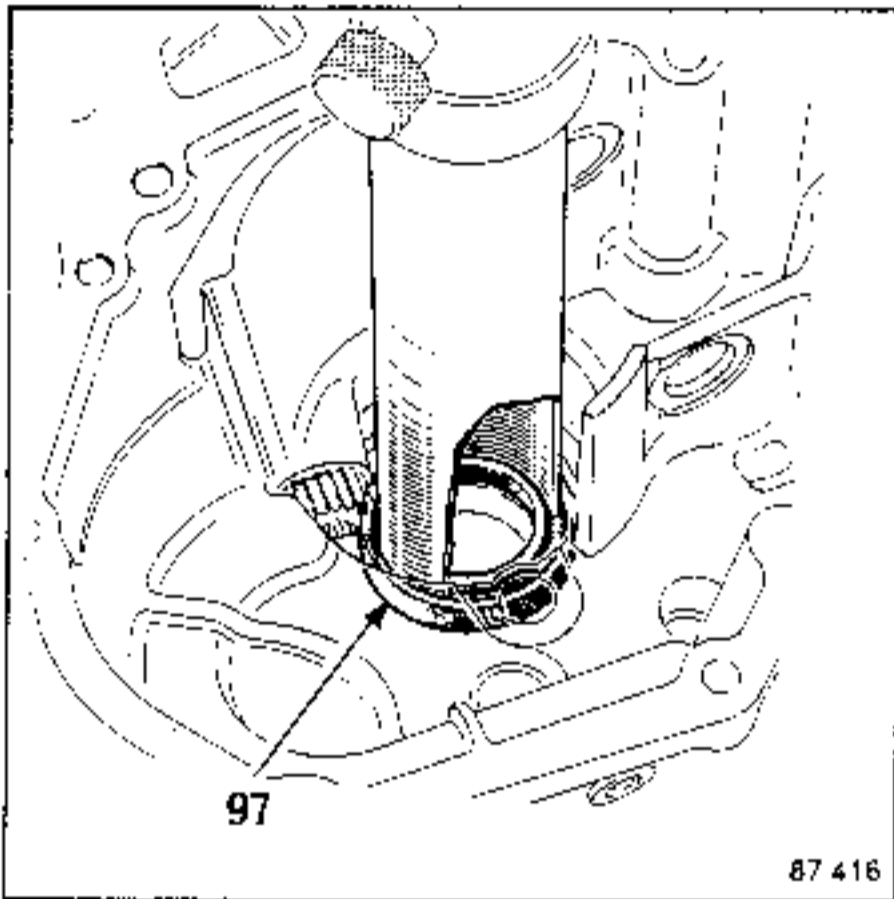

All types:

Move apart notches (C) holding the drive gear on the shaft. Pull the speedometer shaft.

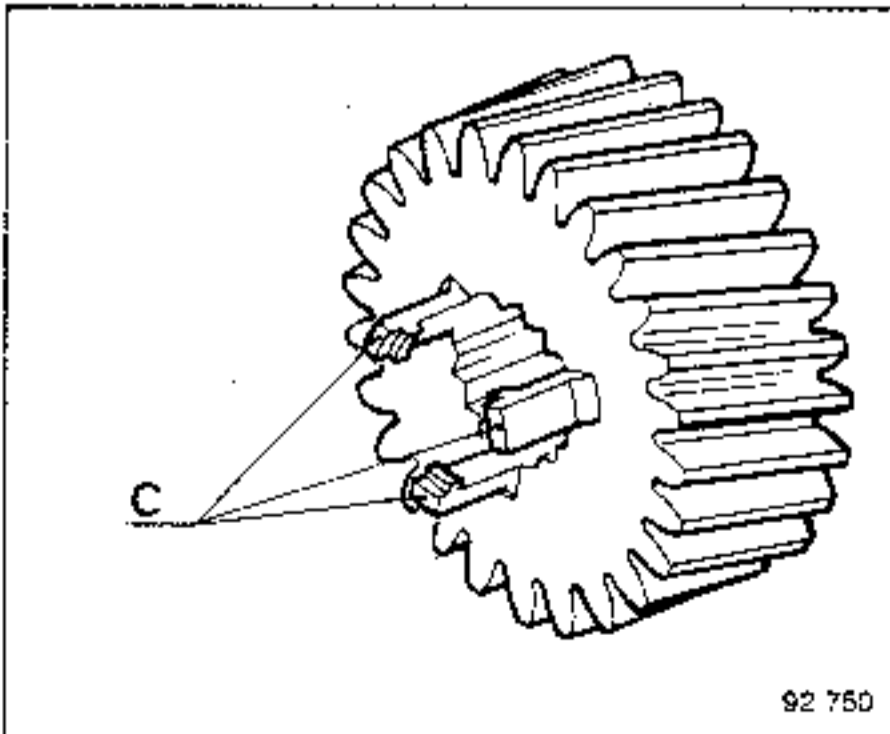

NOTE: The drive gear must be replaced each time it is dismantled.

Remove:

- the speedometer seal using tool B.VI.905-02.

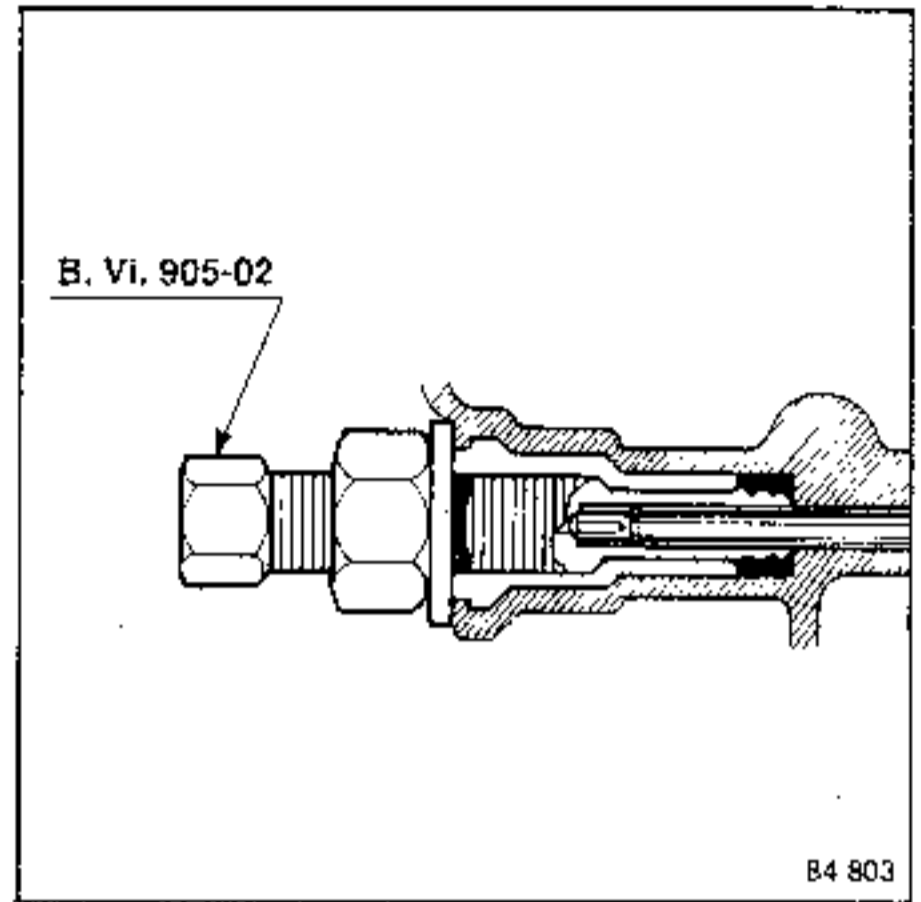

Using a screwdriver, remove the lip seal from the control shaft.

Knock out blanking cover (0) using a 16 mm piece of rod engaged in the control shaft bore.

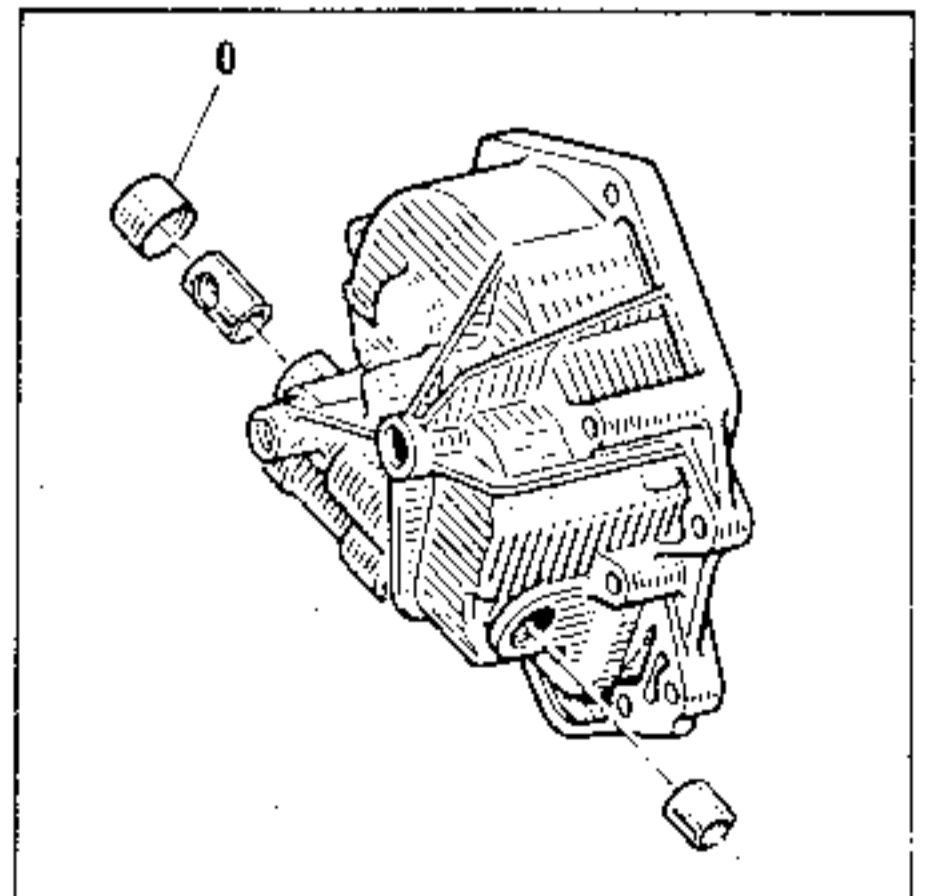

Knock out the bushes using a piece of tubing with an outer diameter of 17 or 19 mm (depending on the assembly).

REAR CASING

Reassembly:

TIGHTENING TORQUES (in daNm)	
Vacuum capsule mounting bolts....	0.1±0.5
Capsule support mounting bolts	2.5
Dog clutch shaft bearing bolts	1.6
Switch	2.5
Flange bolts	7
Output shaft nut (Espace Quadra).....	12

Fit the two bushes, using the piece of tubing, used on dismantling, and a small plastic hammer.

Make sure the parts are in the correct position.

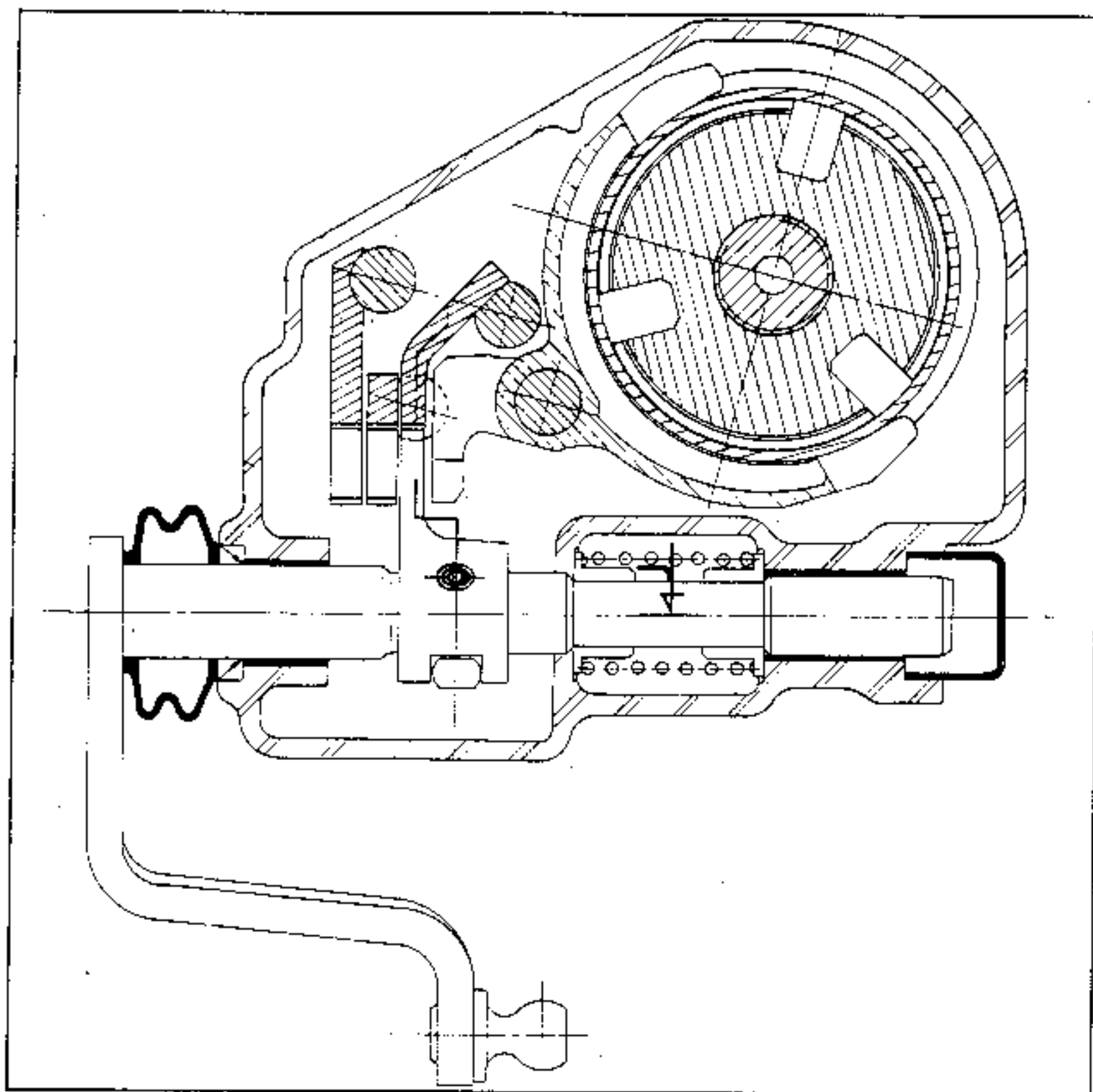

REAR CASING

Refit:

- the speedometer shaft seal (using tool B.VI.905-02);

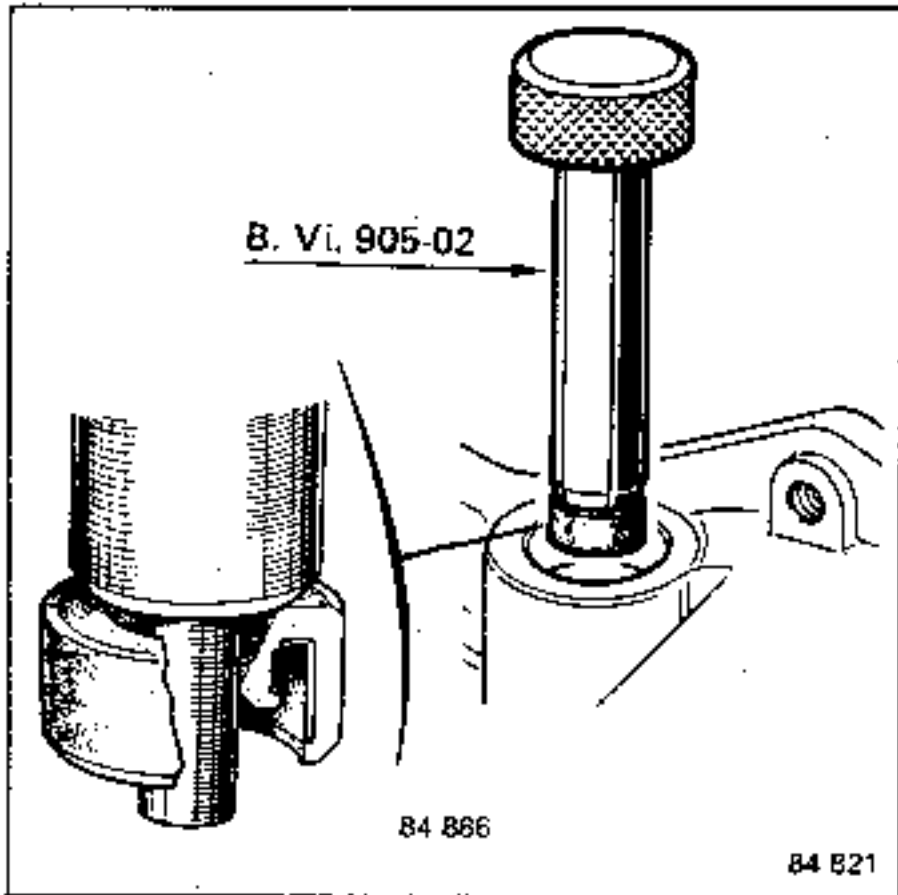

- the speedometer drive gear and shaft.

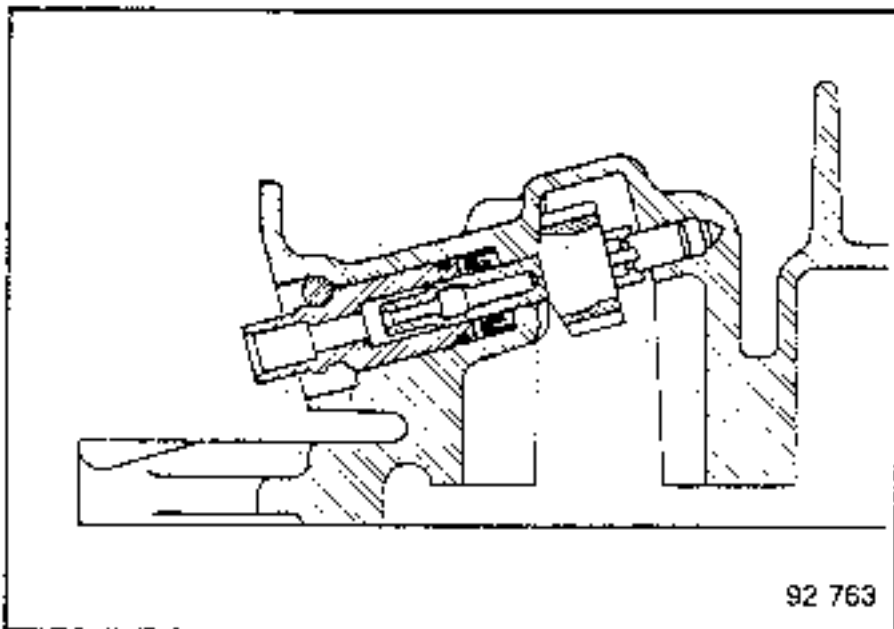

Ensure that the speedometer drive gear is correctly clipped in place on its shaft.

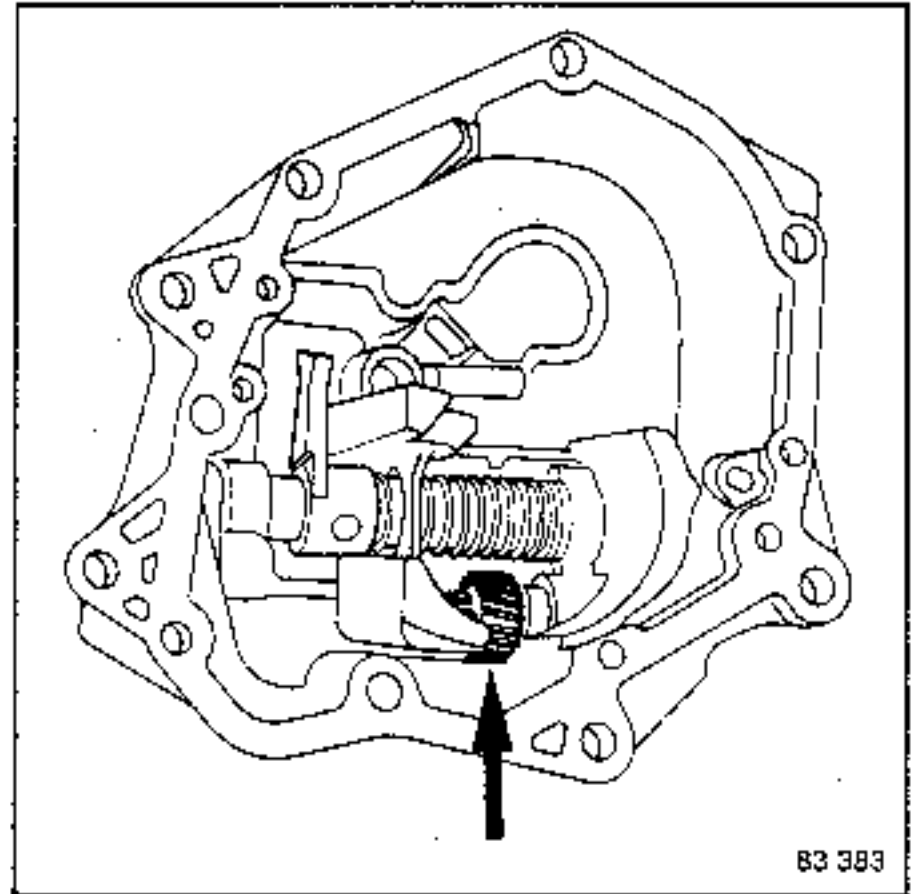

REAR CASING

NG7:

Fit the bearing on the press, taking the weight on the bearing outer track ring.

Fit circlip (99).

Fit the shaft on the press, taking the weight under the bearing inner track ring.

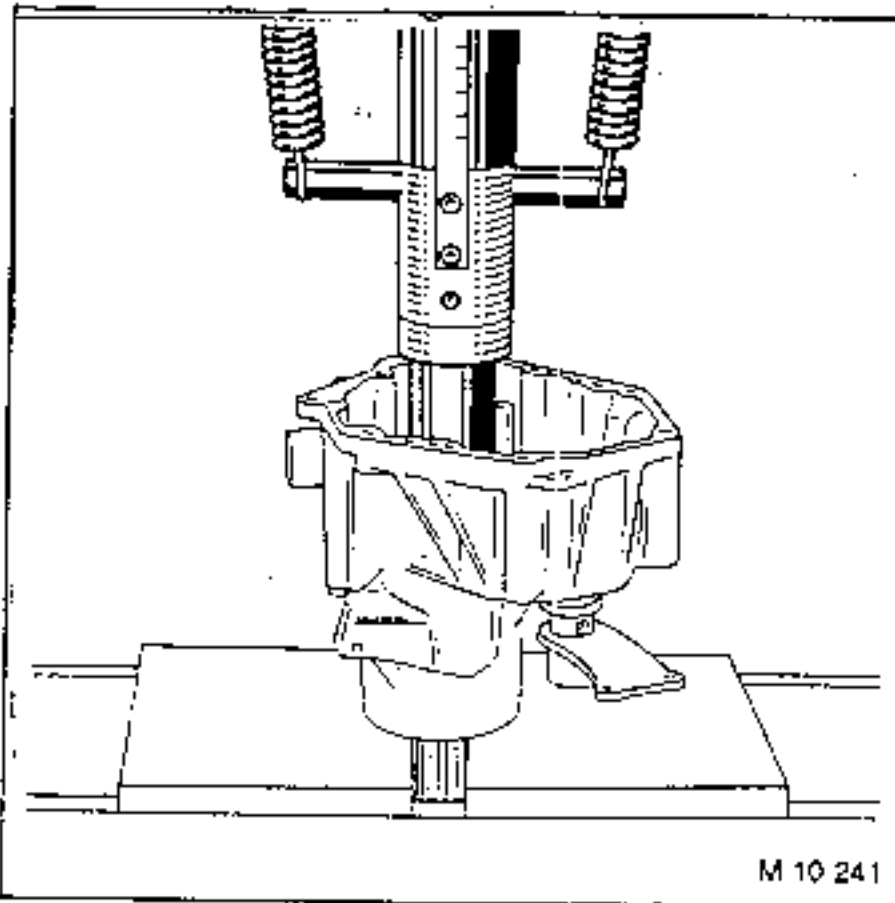

Fit the shaft and selector lever (85) fitted with the shim (1st type) and two greased O-rings (86).

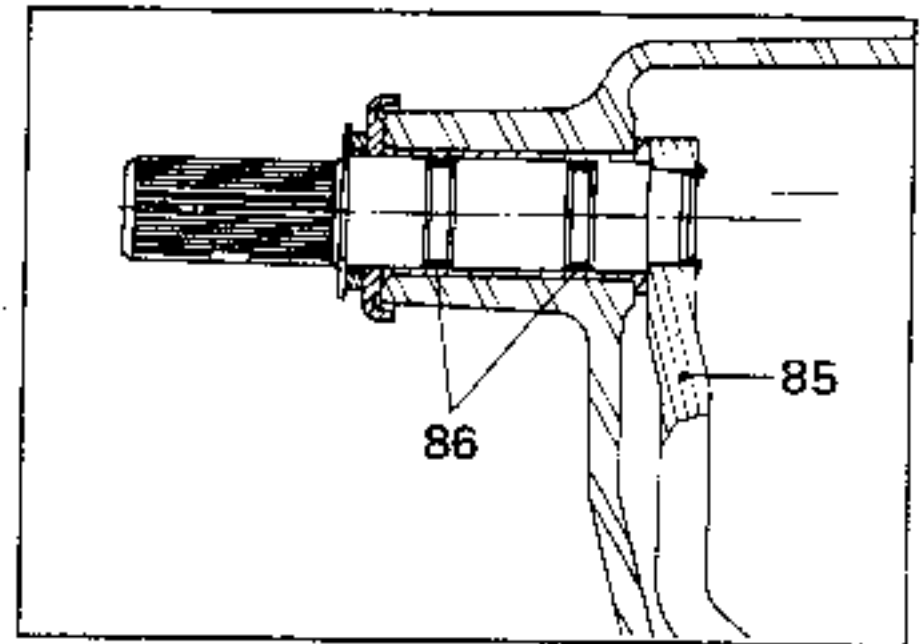

NG0 - NG2 - Special point

The selector lever must be fitted after the selector finger (81) and shaft.

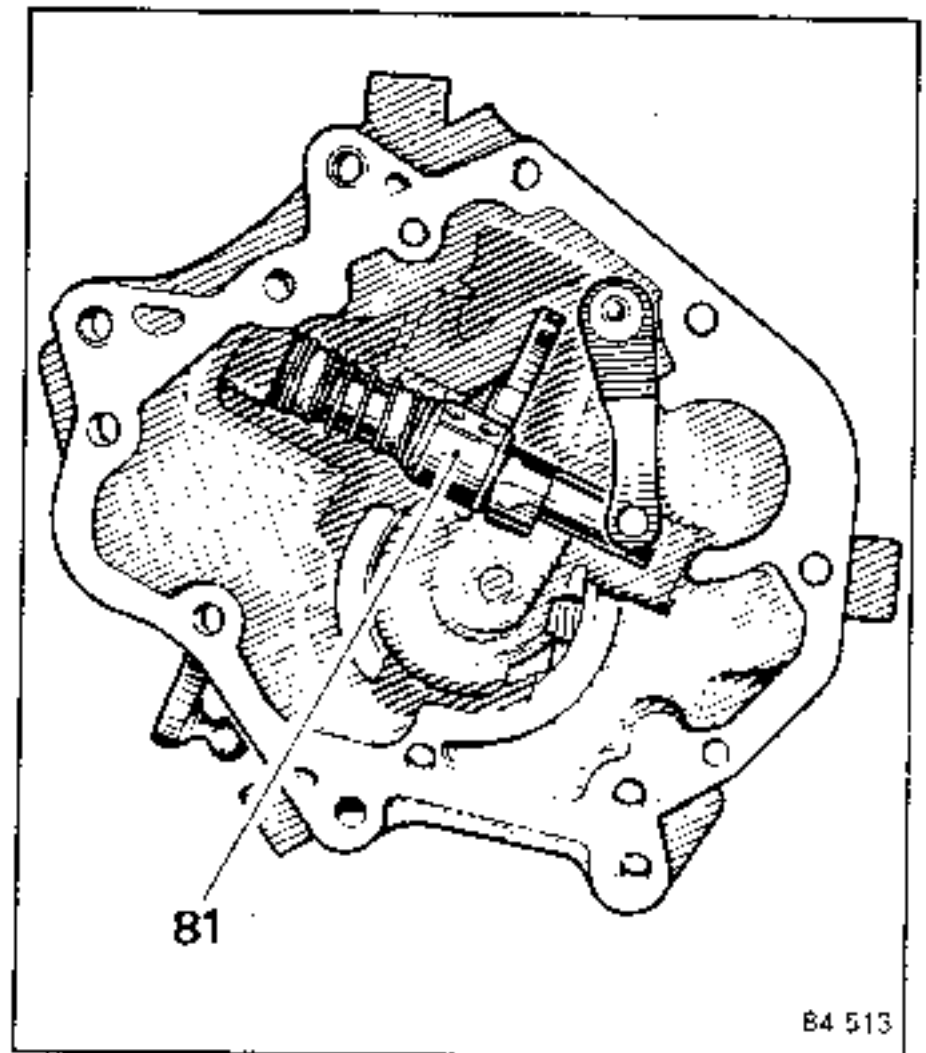

Turn the shaft and check that the speedometer drive gear rotates.

Remove any burrs with fine emery cloth so as not to damage the seals.

REAR CASING

Refit in order:

- the greased lip-seal, so that it is against the shoulder on the casing;
- blanking cover (O) coated with CAF 4/60 THIXO.

Remove any burrs from the shaft with fine emery paper so as not to damage the new lip-seal.

Refit in the casing:

- the selector lever shaft fitted with the shim and the two O-rings (greased);
- the spring;
- the selector finger;
- the shaft and its gaiter.

Using tool B.Vi.747 compress the spring and fit the half-shells.

Fit the rollpin in the selector finger (using tool B.Vi.606).

Make sure the rollpins are fitted the correct way round.

The slots in the rollpins must be at right angles to the shaft and facing different directions.

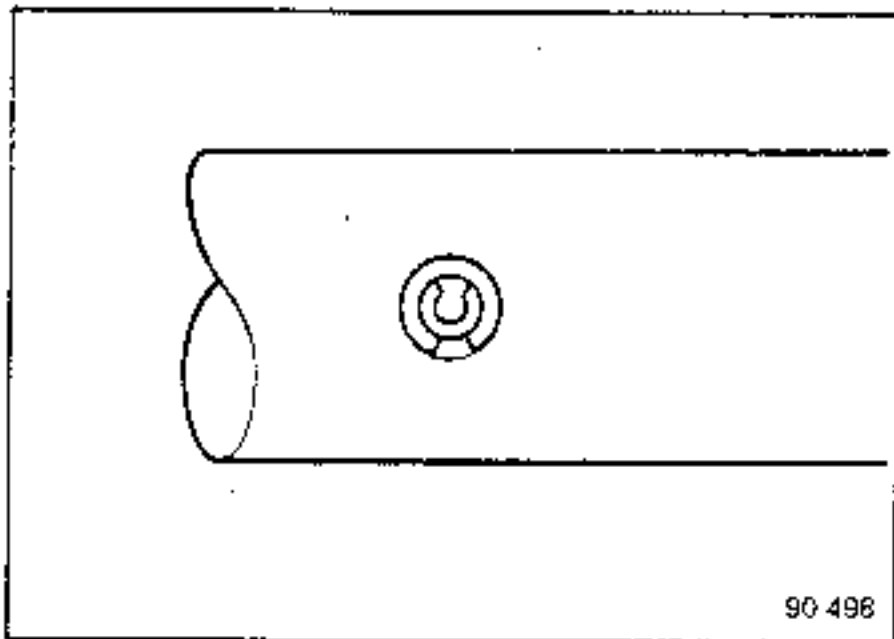

NG5:

The slots in the rollpins must be at right angles to the shaft and facing different directions.

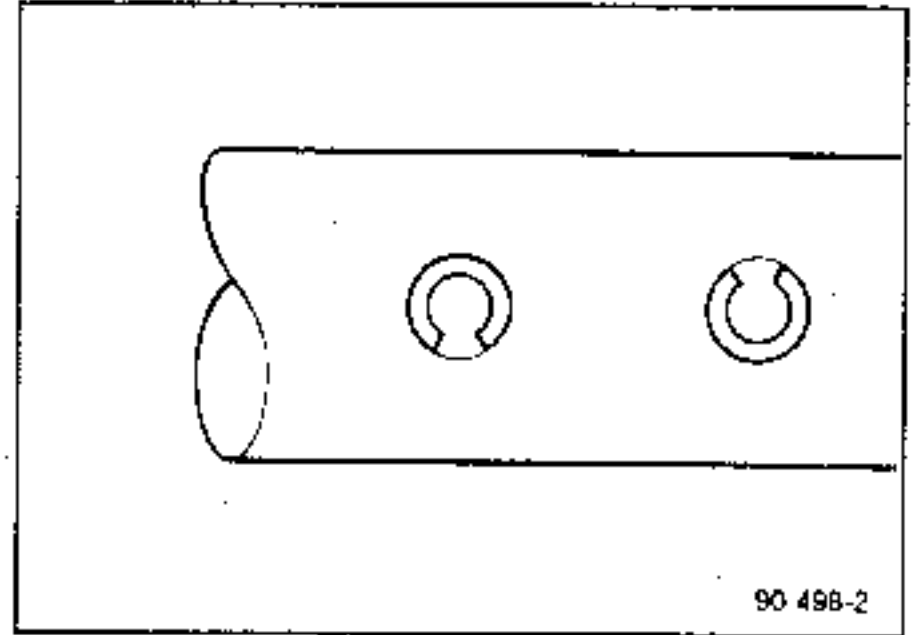

NG1 - NG3 (1st type)

Refit the plunger and detent plunger spring for the reverse gear, with the plug coated with CAF 4/60 THIXO.

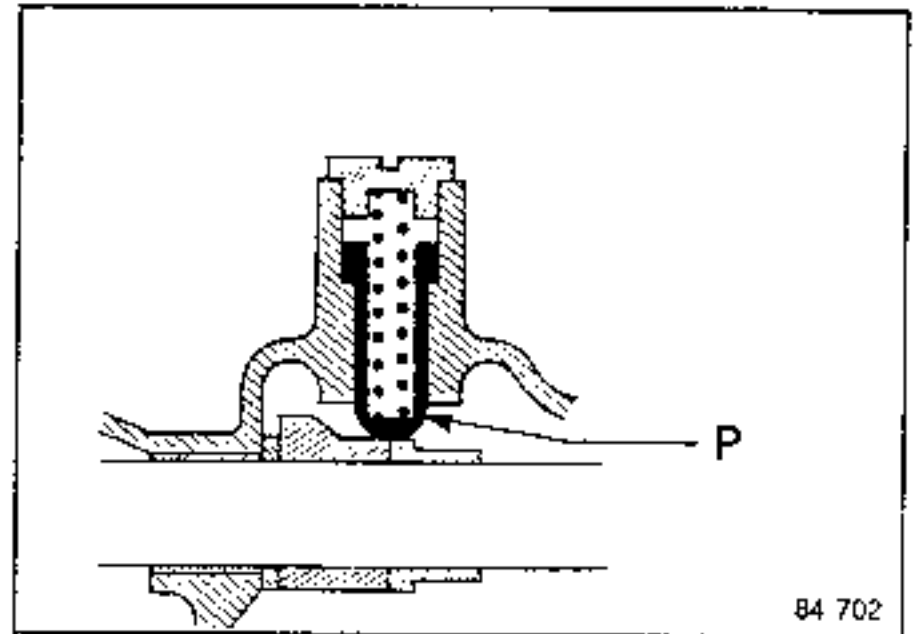

Check that the shaft slides properly and that there is no play.

NG7 REAR CASING

Refit the dog clutch shaft bearing.

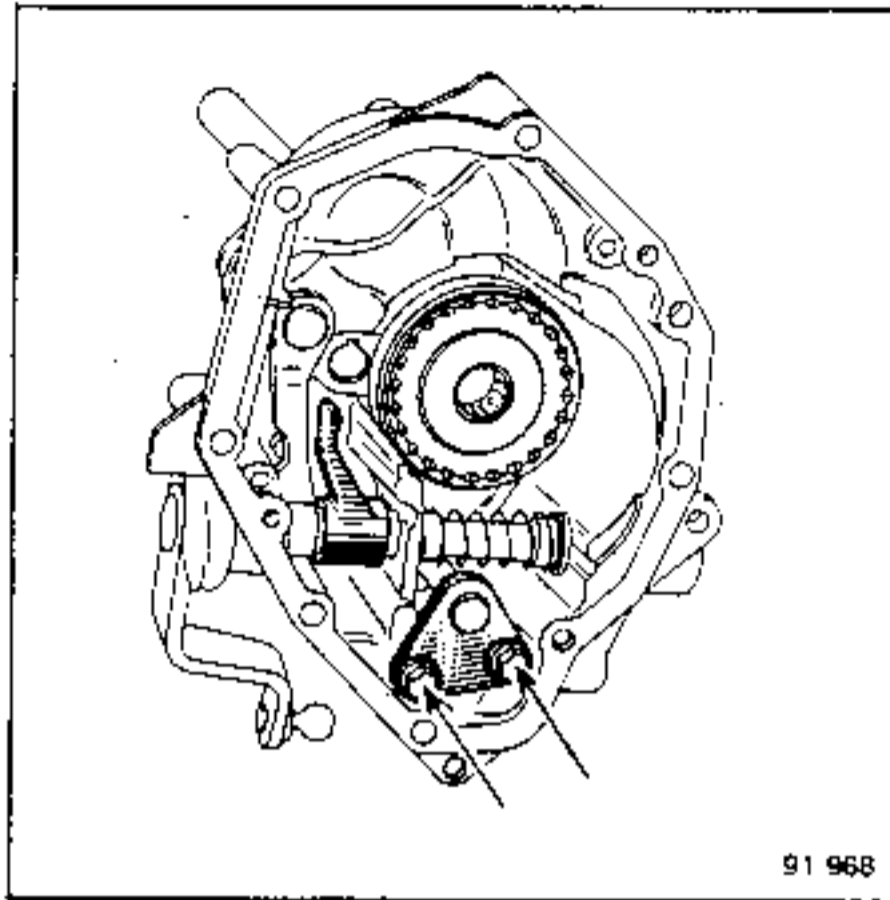

91 968

Position and secure the vacuum capsule mounting, after fitting the rear casing mounting bolt.

Fit the vacuum capsule.

Place clevis (105) for the control rod on the dog clutch shaft.

Fit in place shaft (106), pin (107) and the protector.

Check that the fork-shaft-slide gear assembly slides freely.

Refit:

- the dog switch;

- the flange: the new mounting bolt (greased) must be torque tightened to 7 to 8 daNm.

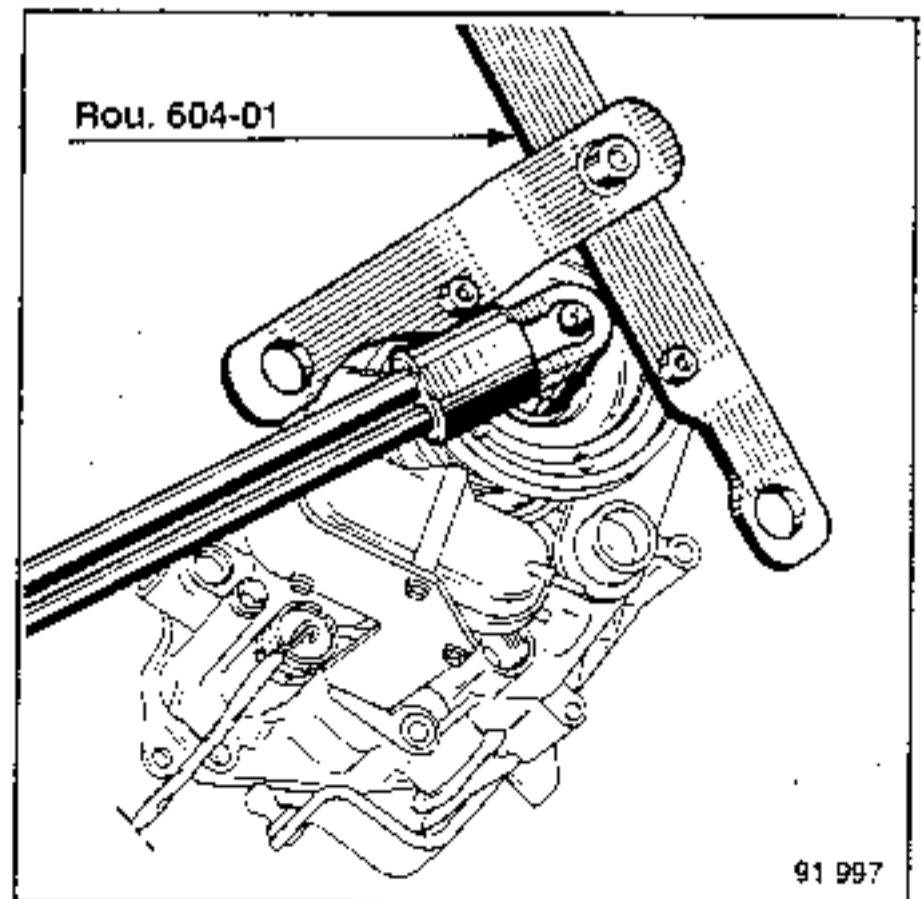
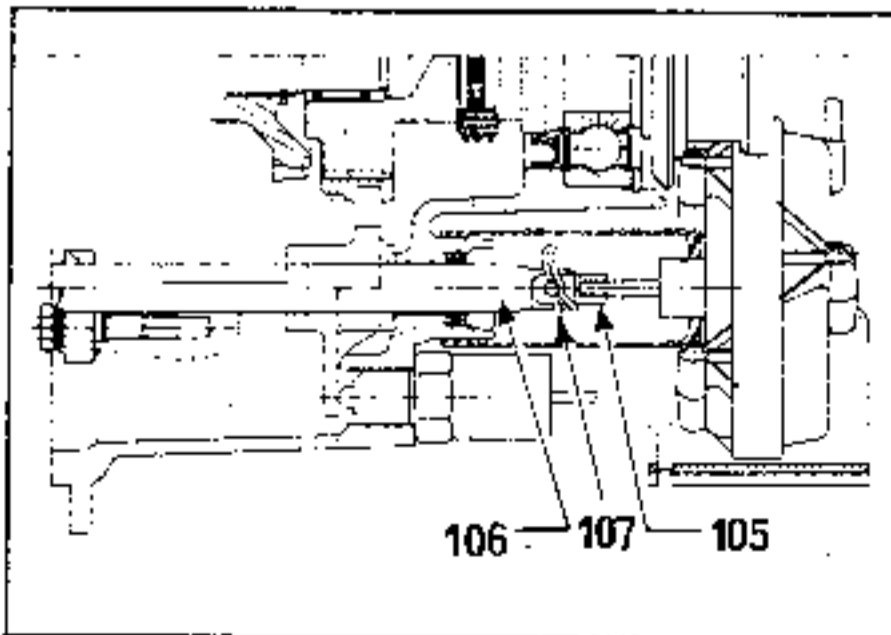

Rou. 604-01

91 997

CLUTCH CASING

Replacing the clutch fork

1) For "push type" clutch

1st type

Removal:

Take the rollpins out of the fork using tool **Emb. 880**.

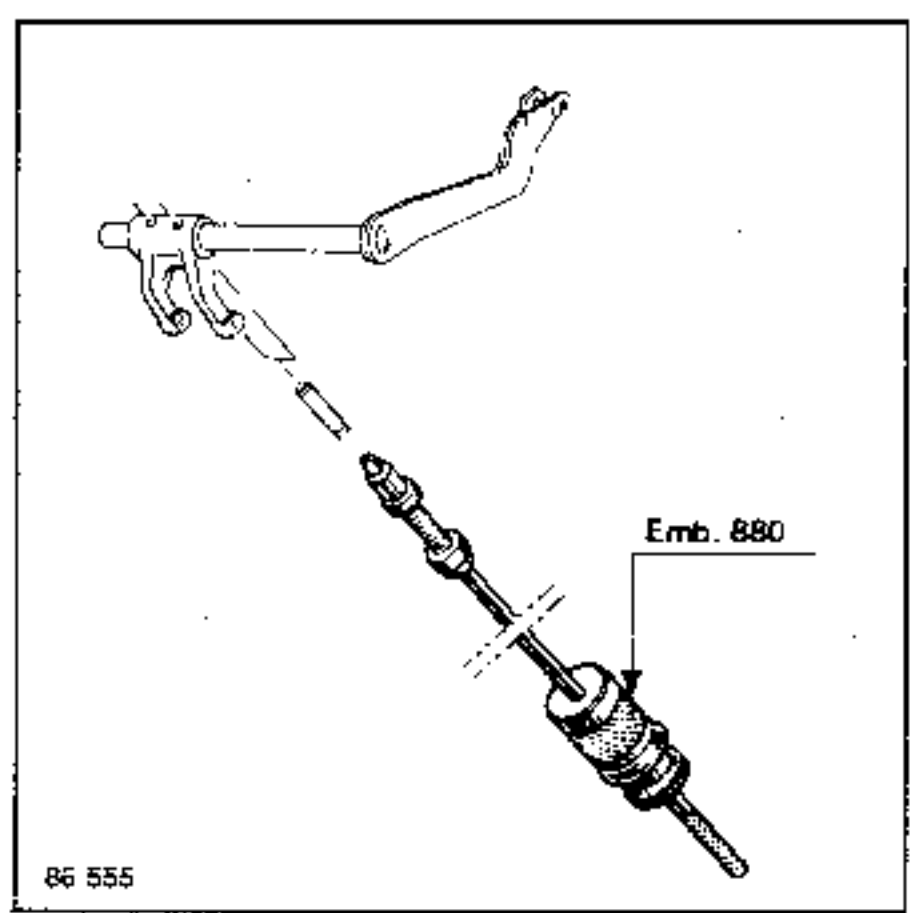

Refitting:

Special point

Grease the fork shaft with **No. 20** grease.

Fit the rollpins: make sure protrusion **D** in relation to the fork is **1 mm**.

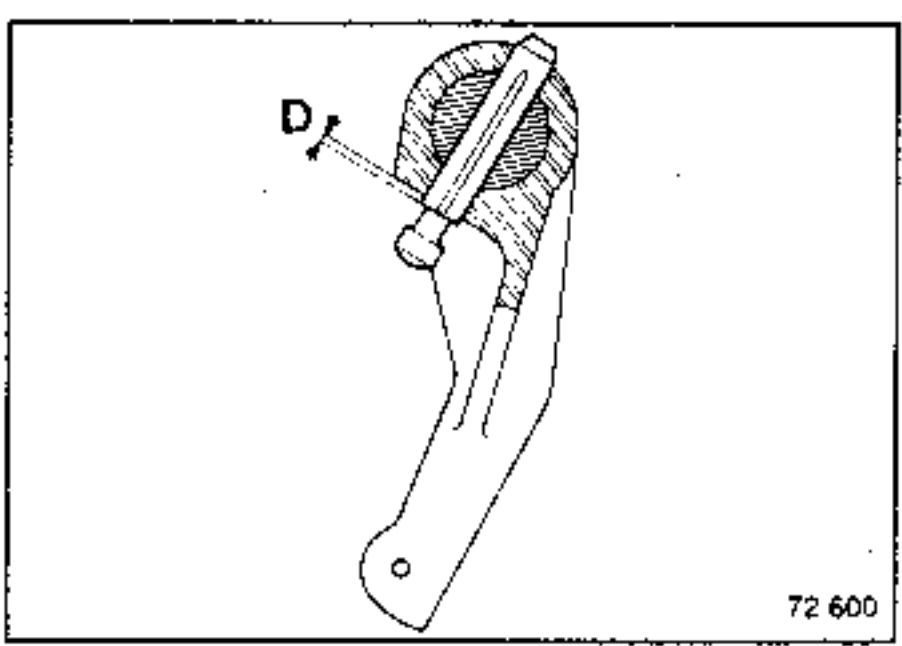

2nd type

Removal:

Remove the thrust pad.

Disengage the fork from the pivot and take it out through the interior of the casing.

Refitting:

Grease the fork pivot with **No. 20** grease.

Fit the fork in place, with spring (1) behind cup (2).

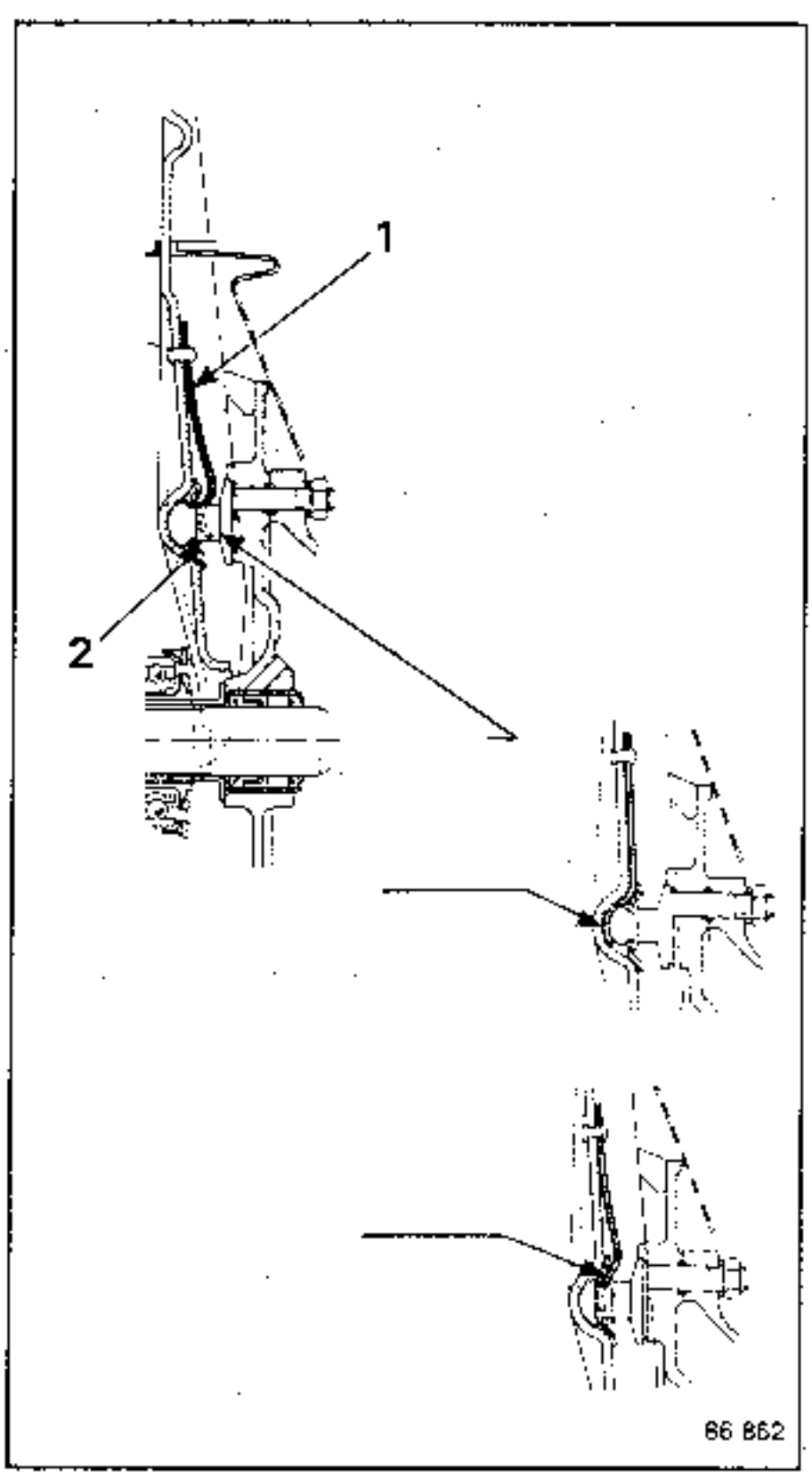

Ensure that it operates correctly.

CLUTCH CASING

Replacing the clutch fork (contd)

2) For the "pull" type of clutch

Removal

Knock out the rollpins holding the fork using tool B.Vi. 606 until the rollpins are half-way out, then use tool Car.41.

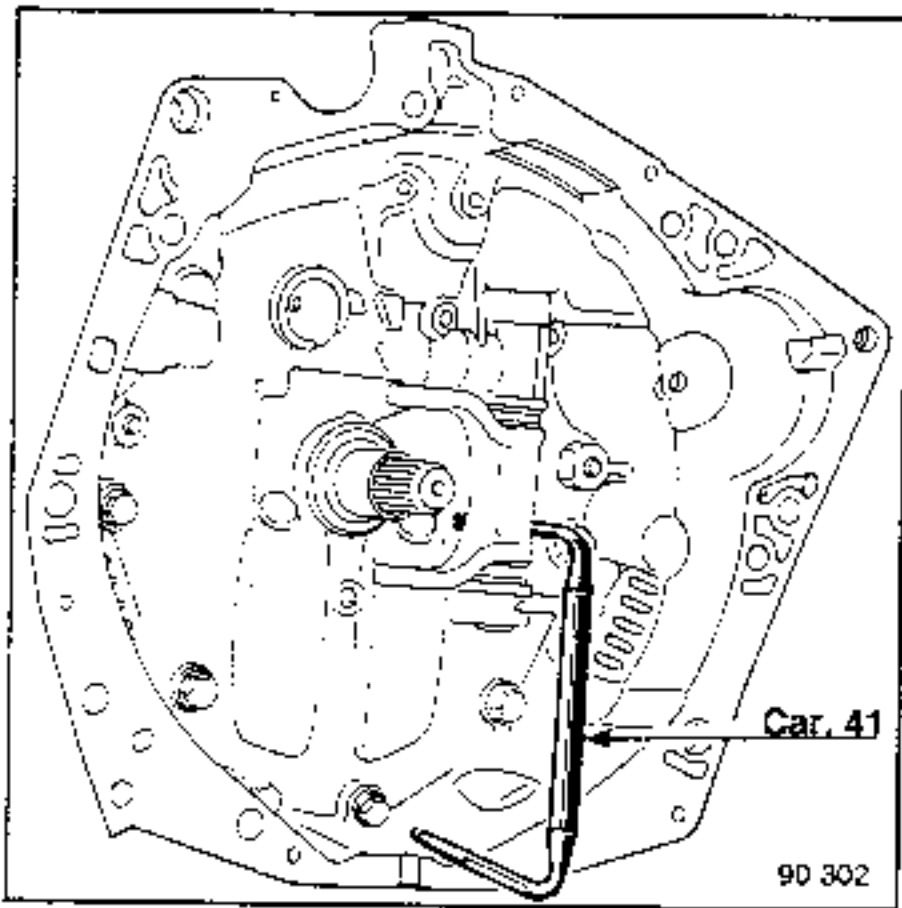

Refitting

Lightly grease the fork shaft with Mobil x 57030 No. 20 grease.

Engage the shaft (fitted with the sealing rubber), fit the fork and two plastic spacers. Make sure the fork is fitted the correct way round, with the boss facing the inside of the clutch casing.

Align the holes in the fork with those in the shaft and fit the rollpins.

Make sure the rollpins are fitted with their slots at right angles to the fork shaft and facing opposite directions.

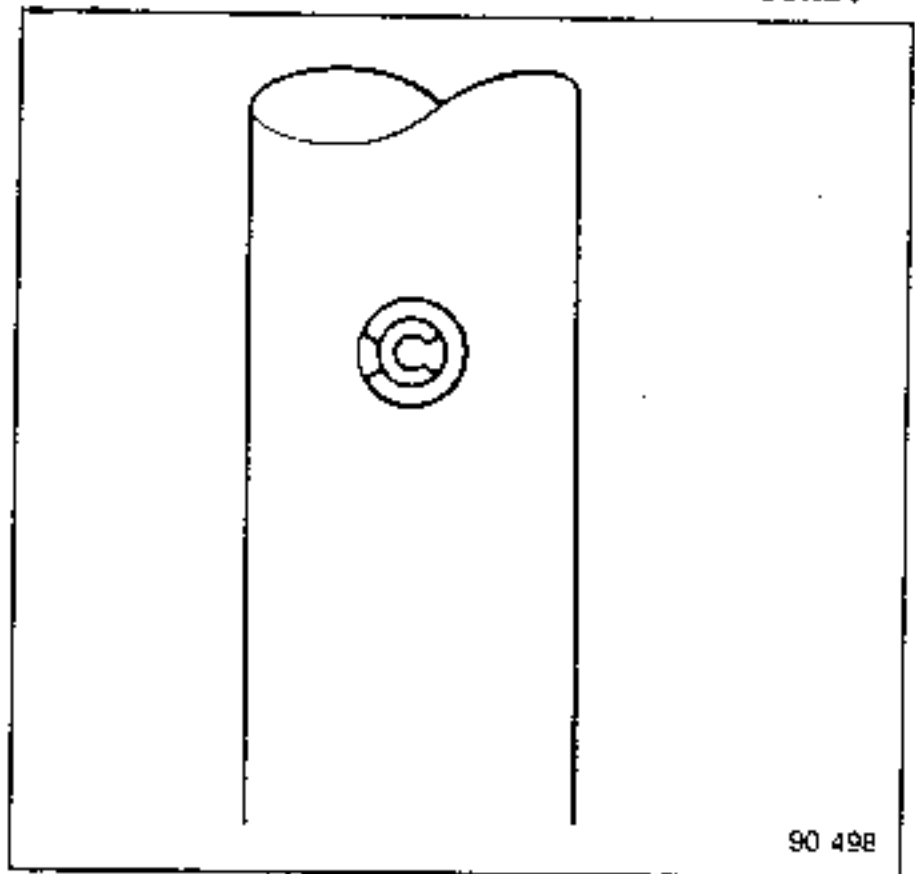

CLUTCH CASING

Centring the clutch shaft

In service exchange, gearboxes with a short shaft (A) or a long shaft (B) can both be supplied:

- gearbox **with** a spigot bearing in the clutch casing: short clutch shaft (A);

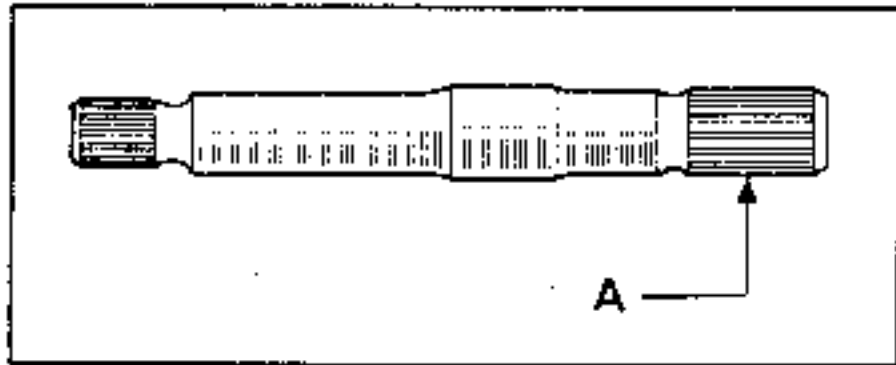

- gearbox **without** a spigot bearing in the clutch casing: long clutch shaft (B).

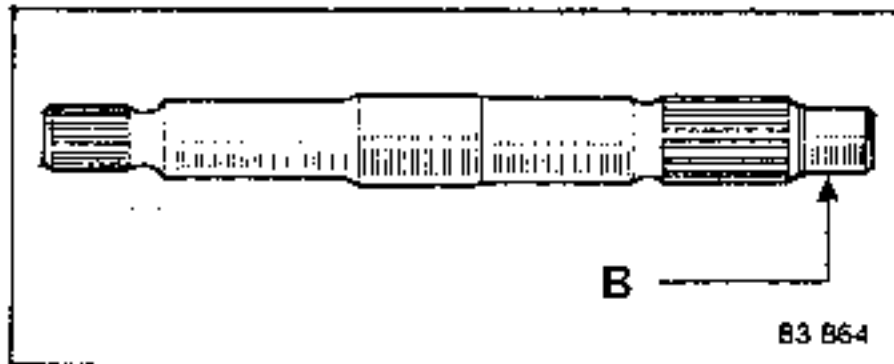

If the gearbox has a long shaft (B), a bearing must be fitted in the crankshaft. If the flywheel does not have a lock plate, bond the bearing on the crankshaft using Loctite FRENBLLOC.

If the gearbox has a short shaft, the bearing on the crankshaft must be removed.

1) Clutch shaft without a spigot bearing

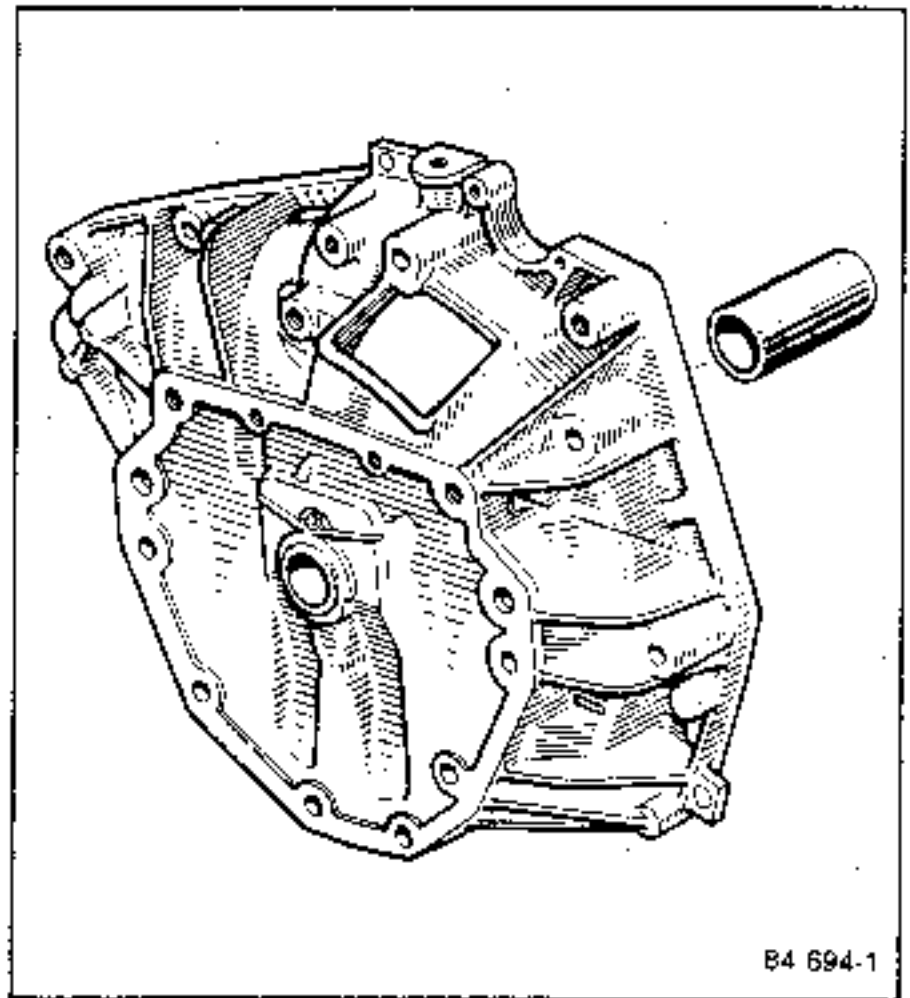

Seal 73 is refitted using tool:

- B.Vi. 488 for cast-iron engines;
- B.Vi. 526 for aluminium engines.

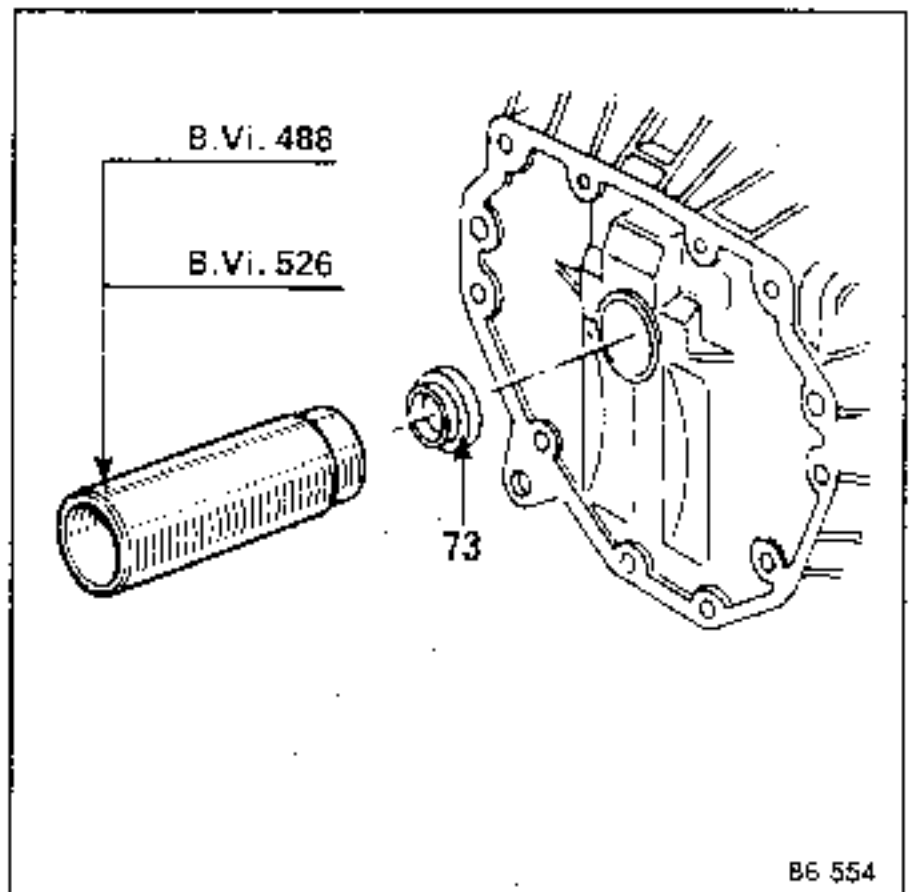

CLUTCH CASING

2) Clutch casing with spigot bearing (guide tube)

The lip-seal and clutch shaft spigot bearing are integral with the thrust pad guide tube.

Lubrication is by means of an aperture leading into the clutch casing bore.

Removal

Take the guide tube out on the press.

When a guide tube has been removed on the press it cannot be re-used.

Removal

Put a thin coating of No. 20 grease on the walls of the bore.

Fit O-ring (T) on the guide tube.

Offer up the guide tube to the clutch casing and align the bearing lubricating hole in the guide tube opposite the hole in the clutch casing.

Insert the guide tube on the press until it is completely fitted.

Check that lubricating hole (A) in the bearing is opposite hole (B) in the clutch casing.

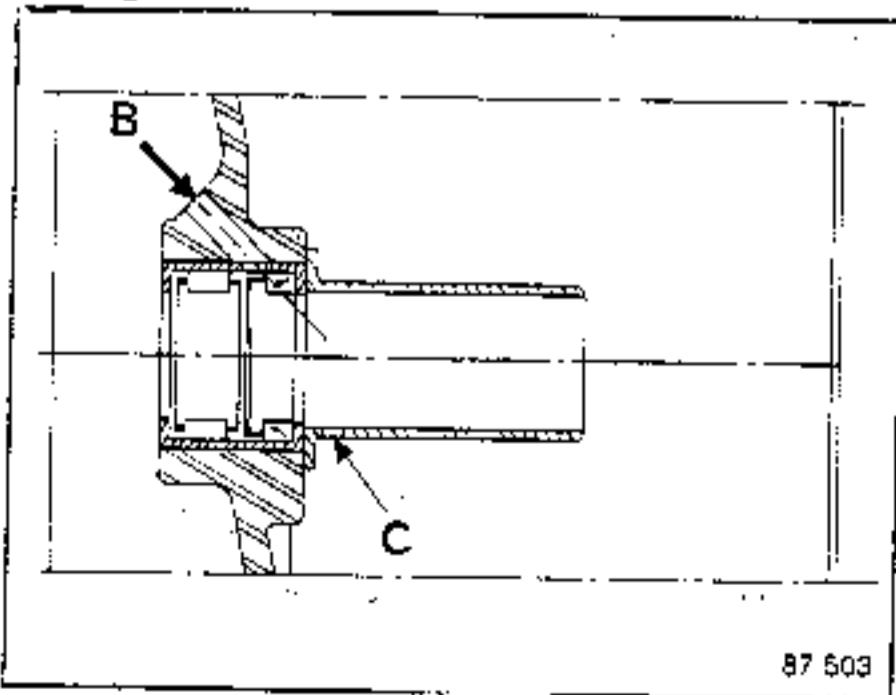

Aperture (C) in the guide tube must face the bottom of the casing.

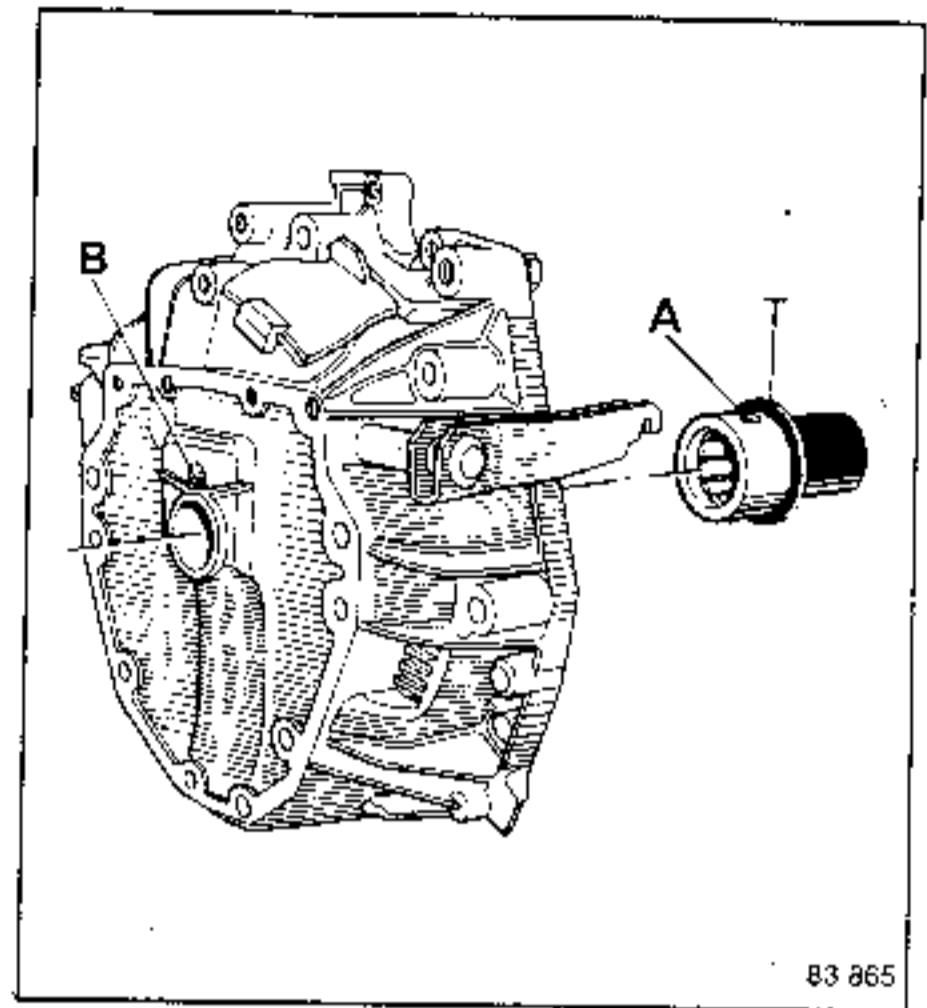

Lubricate the seal before fitting the shaft.

NOTE: The lip seal and bearing are in direct contact with the clutch shaft. If they are fitted incorrectly the clutch shaft will have to be replaced.

ASSEMBLING THE CASINGS

On the lefthand casing:

- Place the reverse gear shaft in neutral.
- Coat the casing joint faces with **Loctite 518**.
- Fit protector B.Vi.813 on the lefthand sunwheel
- Assemble the casings, taking care to position the reverse swivel lever and bearings correctly.

Torque tighten the casing mounting bolts in the order shown and to the recommended torque.

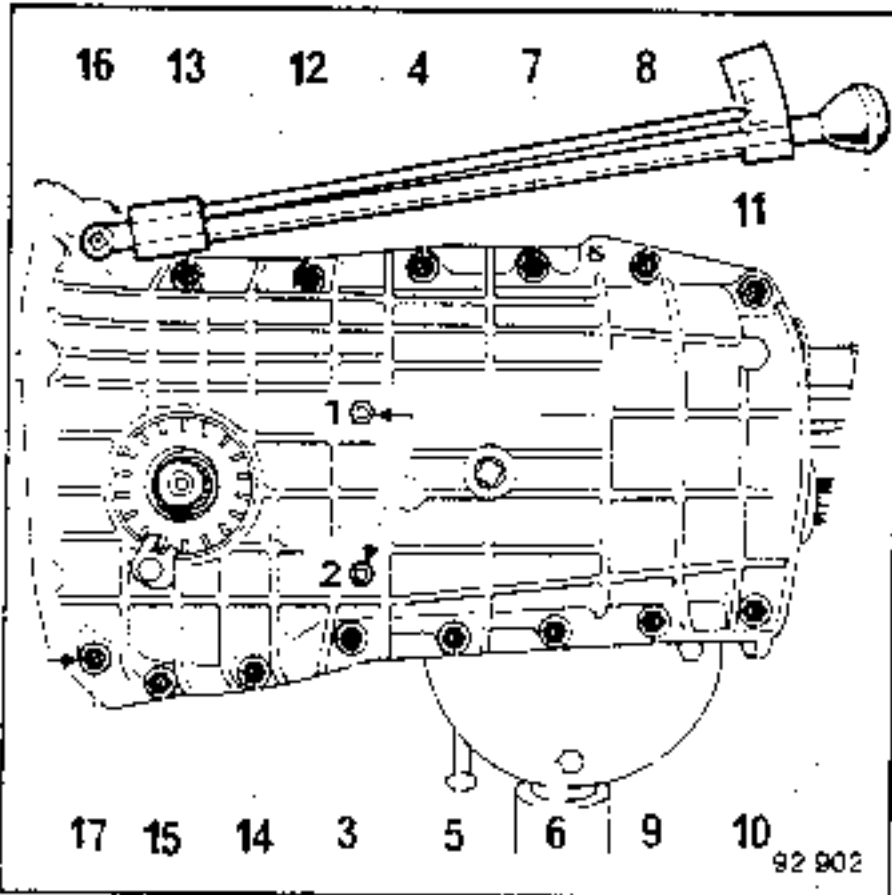

NG0 - NG2: Adjusting the primary shaft bearing pre-load

Fit the shims removed on dismantling and spacer (E).

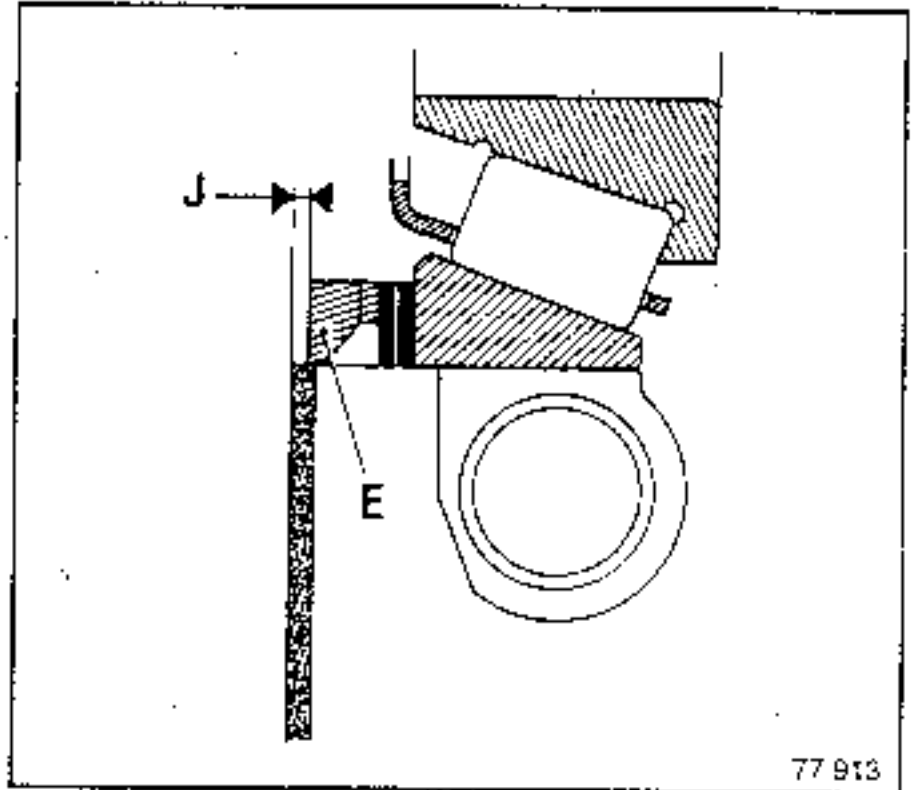

Using a piece of tubing, lightly tap spacer (E) to fit the bearings.

Fit the paper gasket to the rear casing.

Measure clearance (J) between the spacer and the outer face of the gasket:

$$J = 0.02 \text{ to } 0.12 \text{ mm.}$$

If the distance is not correct, increase or decrease the shim thickness (use as few shims as possible).

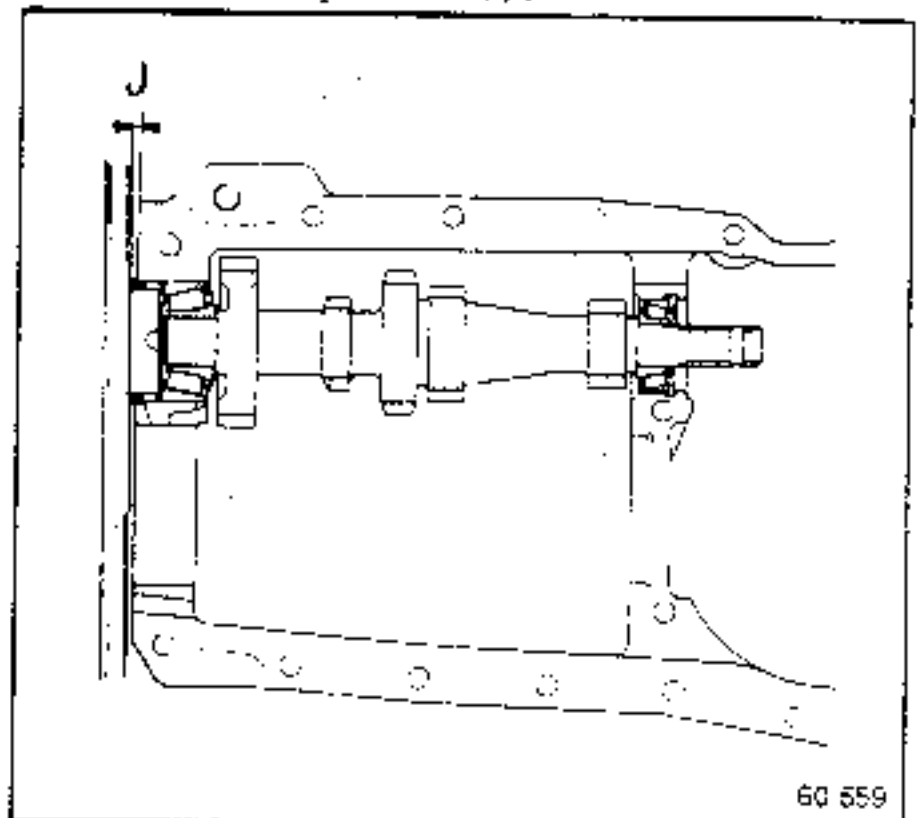

ASSEMBLING THE CASINGS

NG5:

Fit:

- the paper gasket for the spacer plate coated with **Perfect Seal**;
- the spacer plate, centring rebate (L) on the secondary shaft bearing.

Tighten the bolts holding the plate.

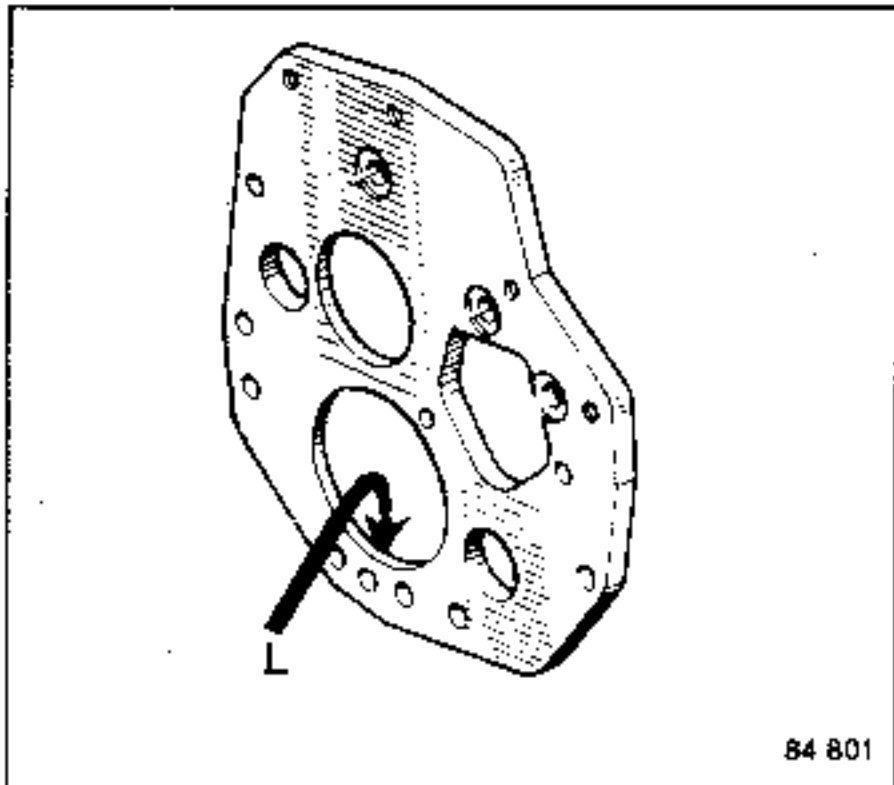

Make sure the fixed gear is fitted the correct way round.

On the secondary shaft:

Make sure the fixed gear is fitted the correct way round and bond it with **Loctite FRENBLOC**.

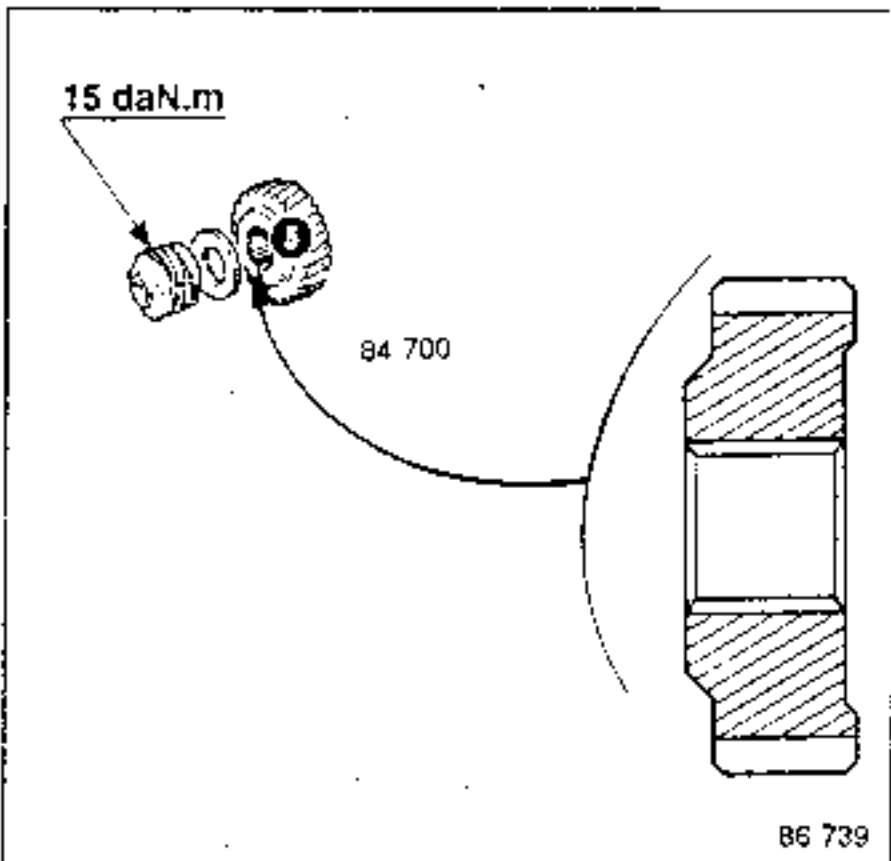

On the primary shaft:

Bond the hub with **Loctite FRENBLOC** and make sure the assembly is fitted the correct way round.

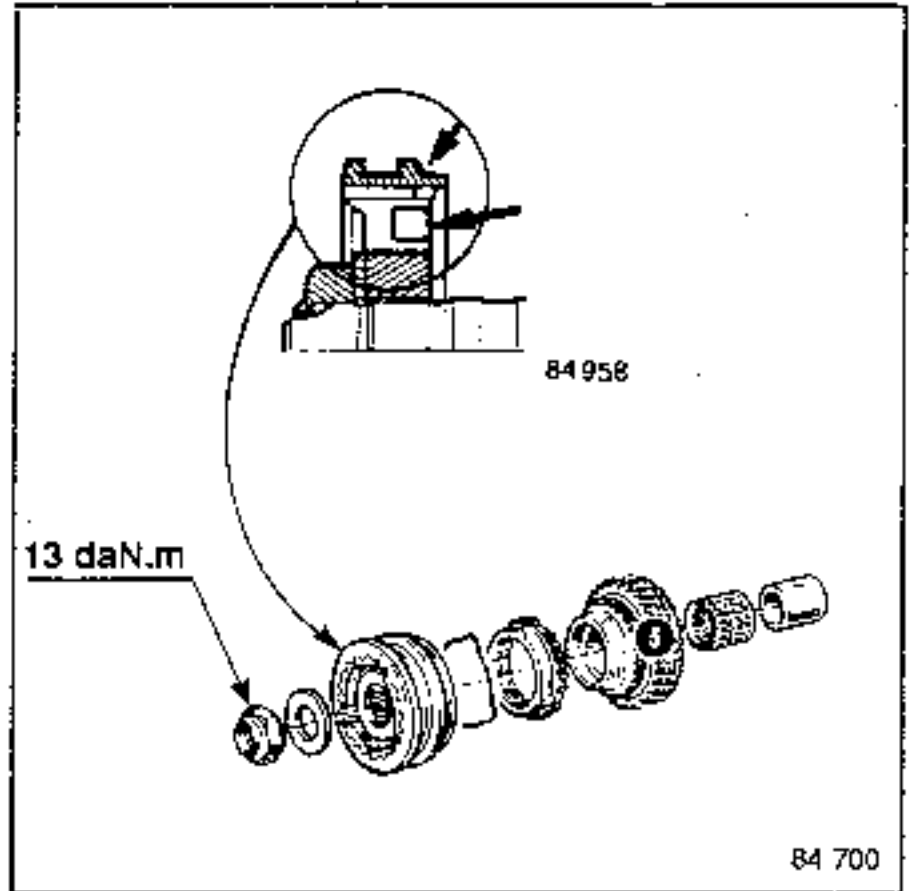

Place the bosses on the synchro rings in the notches on the hub.

Put back the 5th speed synchro/hub/slide gear/fork assembly.

Select 1st and 5th gears.

Put three drops of **Loctite FRENBLOC** on the threads of the new nuts, torque tighten and lock them:

- primary shaft : 13 daNm
- secondary shaft : 15 daNm

Return to neutral and check that all gears can be engaged.

ASSEMBLING THE CASINGS

NG5:

Fit locking ball (B) and circlip (C).

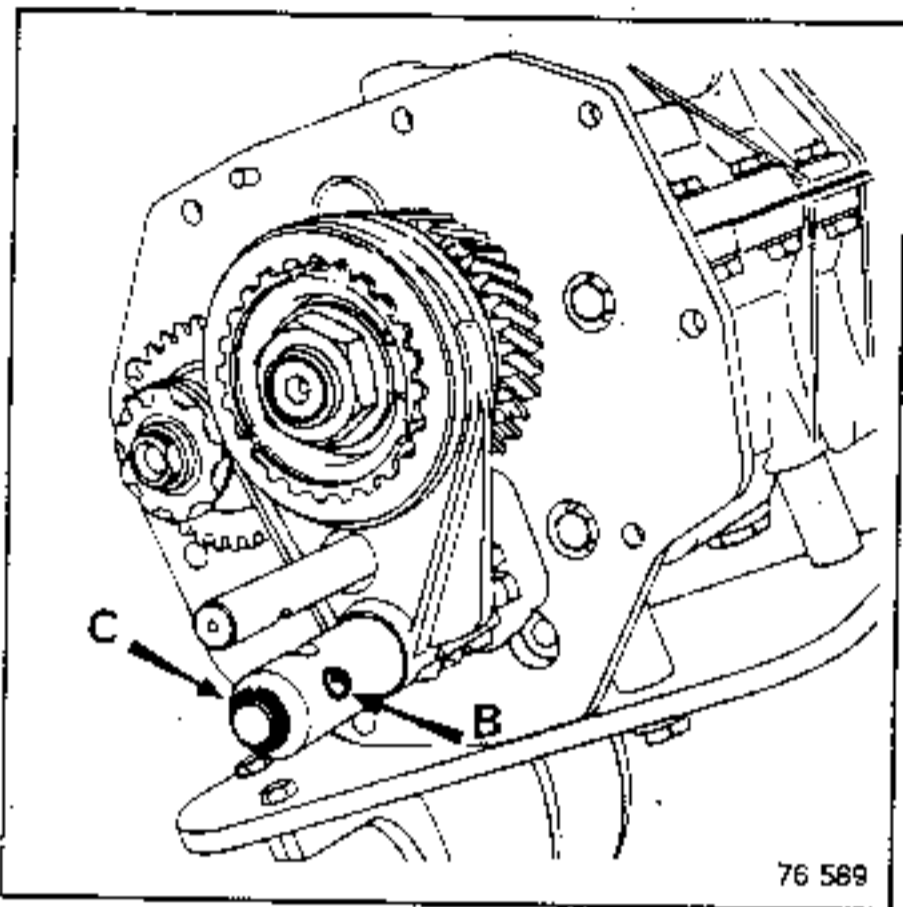

With the gearbox in neutral, fit:

- the rear casing with its paper gasket coated with **Perfect seal**;
- the 5th speed locking ball and spring;
- the 3rd/4th and 5th speed locking ball and plunger;
- the plugs, having coated their threads with **CAF 4/60 THIXO**.

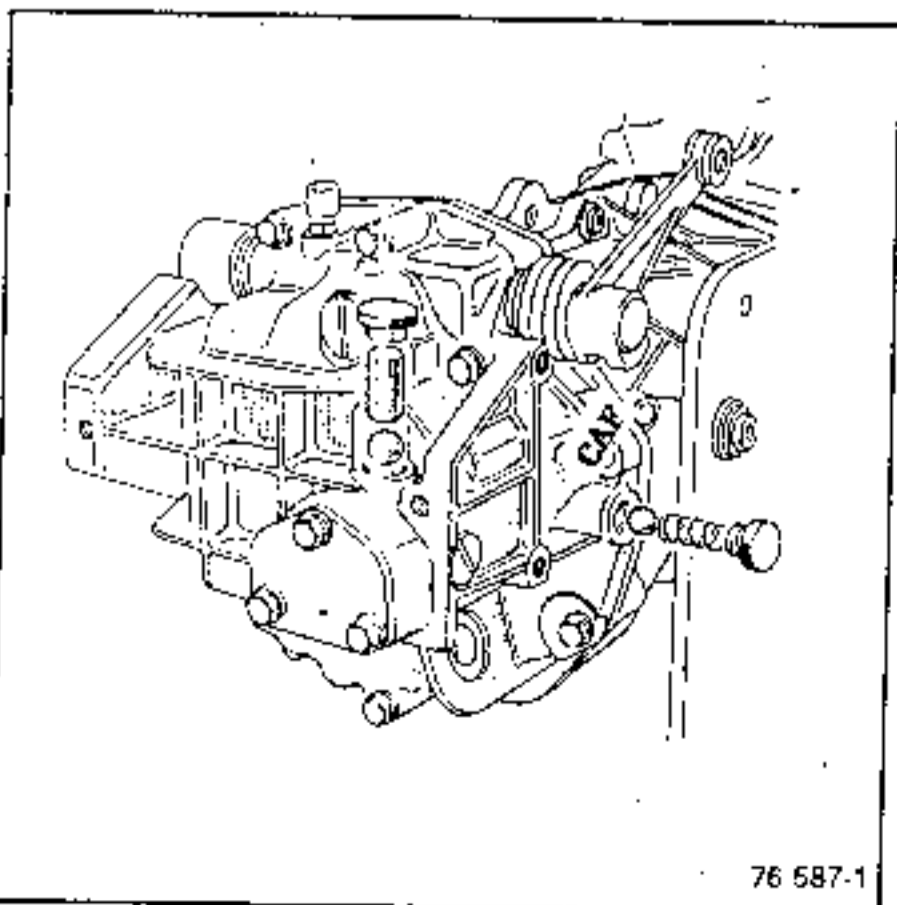

NG 5-speed gearbox - All types except NG5

Select 4th gear.

Fit the paper gasket, coated with **Perfect Seal**, on the rear casing (except on the NG7 where it is fitted dry).

Select 4th gear and position the casing, with the selector finger in the 3rd/4th speed fork shaft dog.

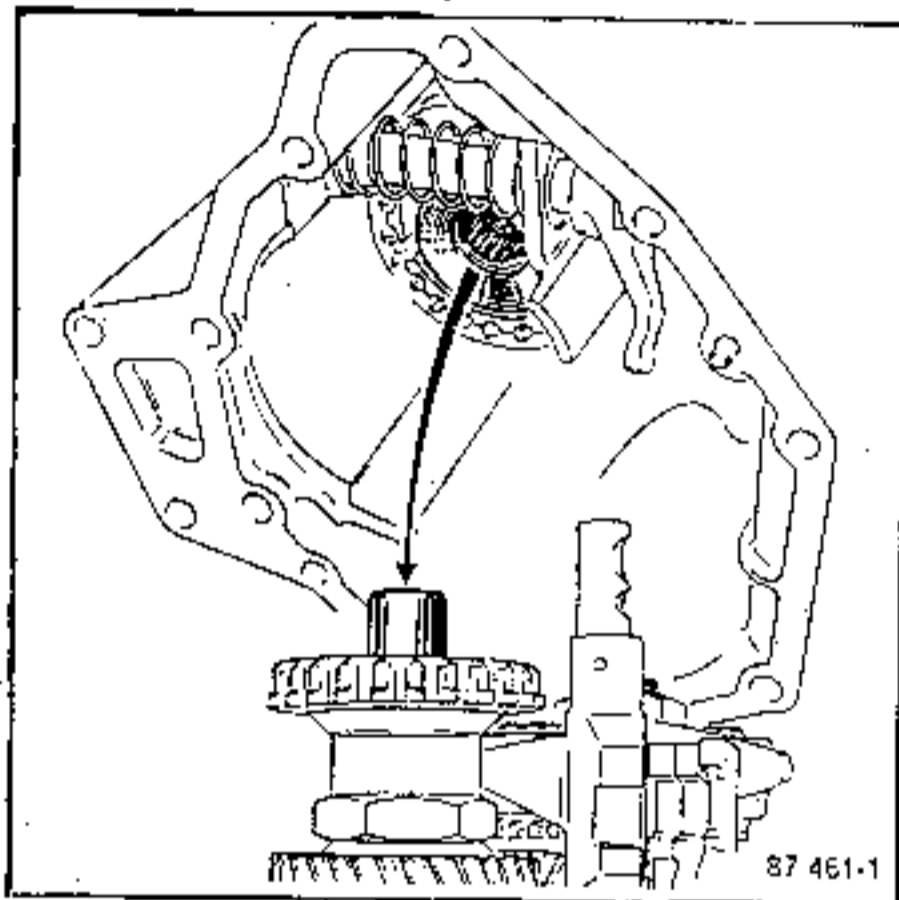

Position the spacer plate so that it locates in its housing in the casing and close the rear casing.

Torque tighten the bolts.

Refit the 5th speed locking ball, after coating the plug threads with **CAF 4/60 THIXO**.

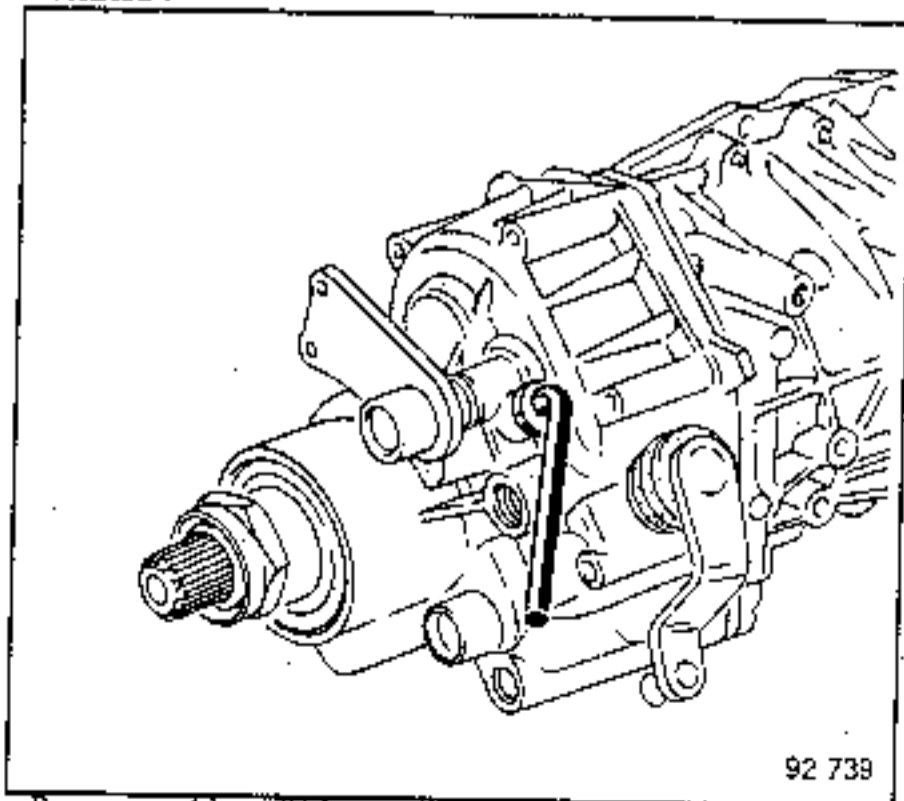

Remove the 4th speed.
Check that all the gears can be selected.

ASSEMBLING THE CASINGS

Check the backlash (at three points 120° apart)

- Secure a clock gauge on the casing, with the probe at right angles to the side of a tooth on the crown wheel, as near to the outer edge as possible.

- Check the backlash: it should be between 0.12 and 0.25 mm.

If the backlash is excessive, unscrew the nut at the casing end and tighten the screw at the crown wheel end by the same amount and vice versa if the backlash is too small.

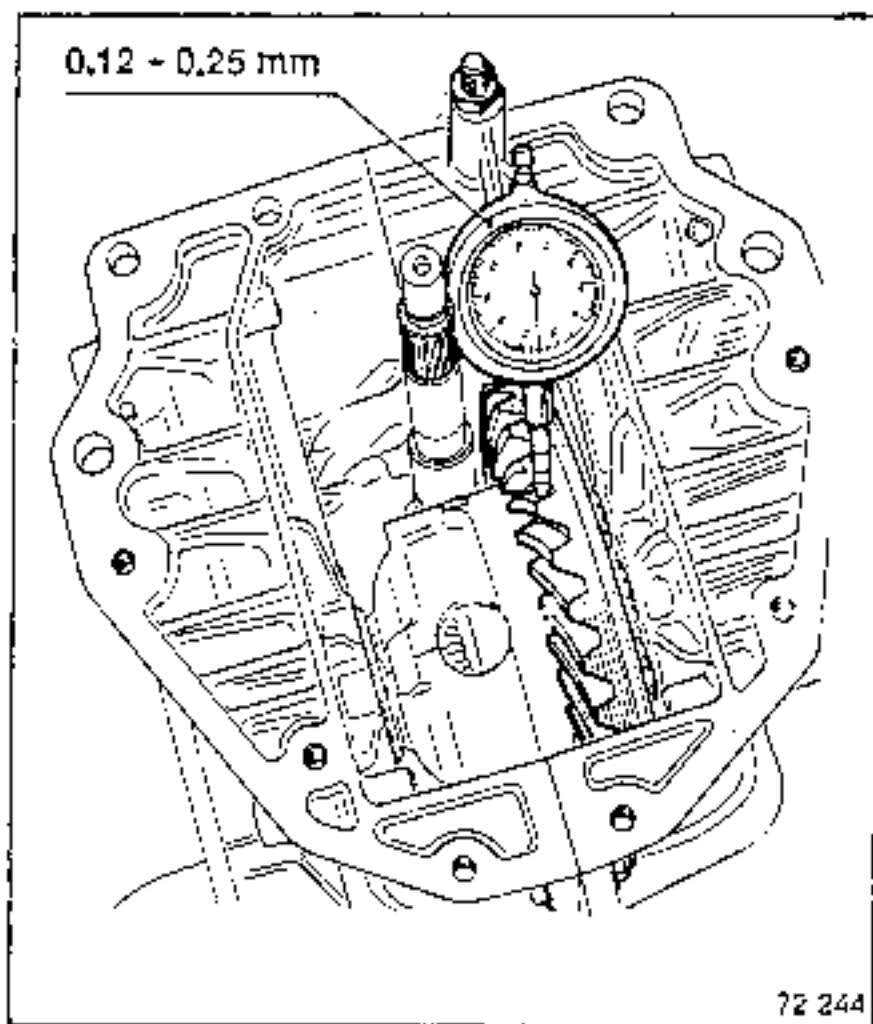

When the backlash has been adjusted, make a new mark on the nut.

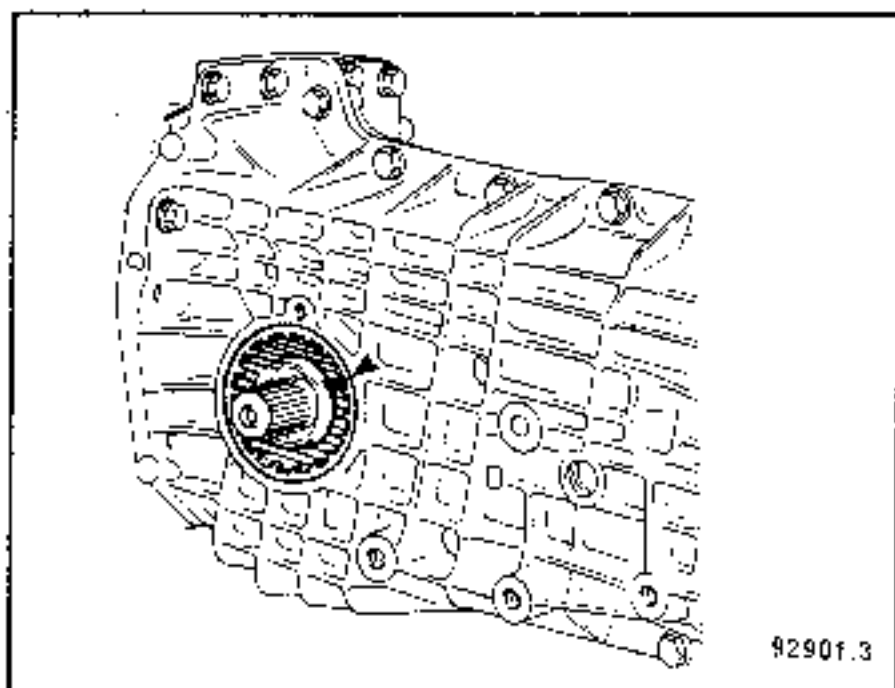

Before assembling the clutch casing:

- check that the locating pins are fitted;
- coat the paper gasket with Perfect Seal.

Long clutch shaft:

Fit the clutch casing, using tooling B.Vi.526 for aluminium engines or B.Vi.488 for cast-iron engines.

These tools are designed to protect the lip seal when it is passed over the clutch shaft splines.

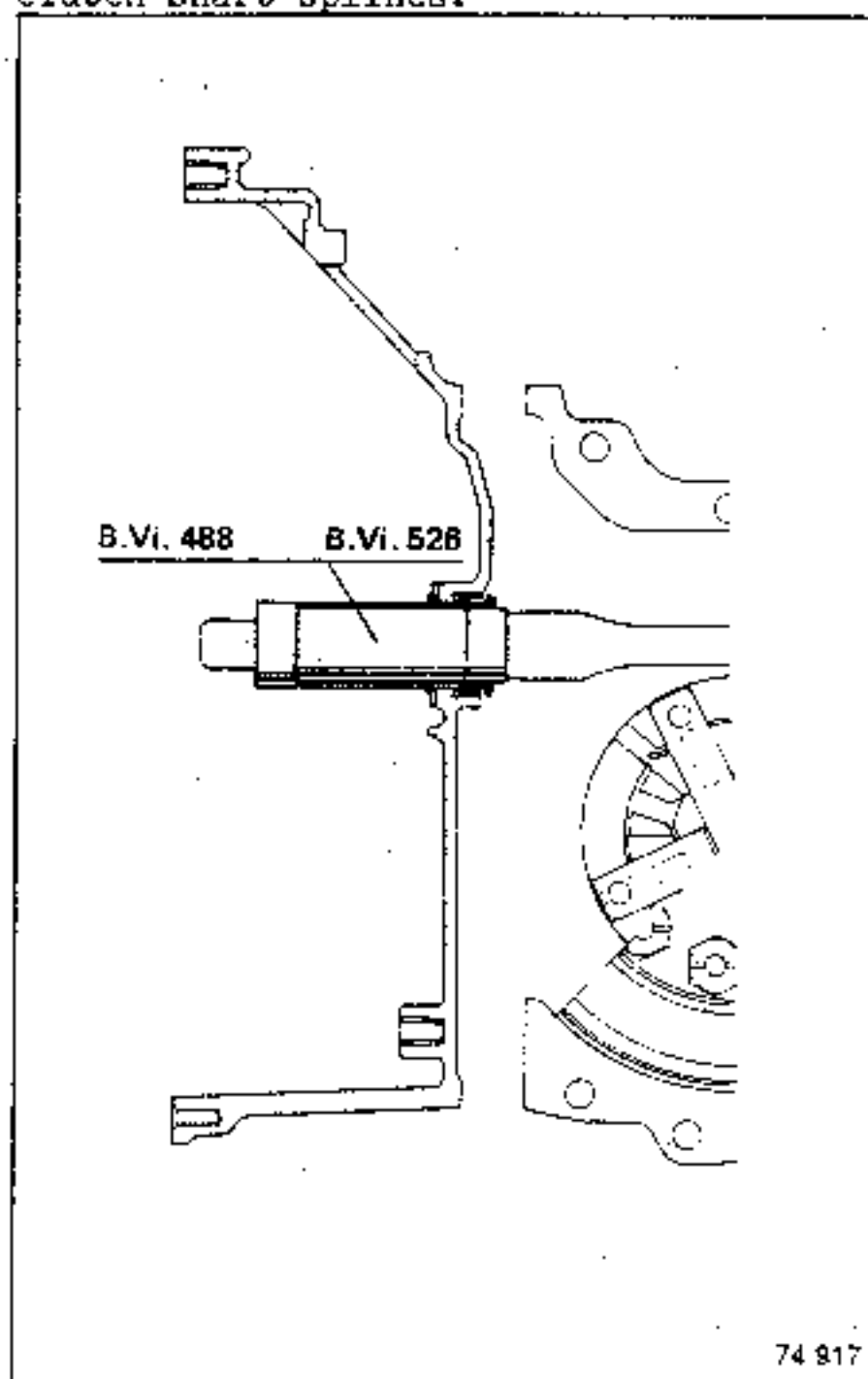

Short clutch shaft:

Place adhesive tape over the shaft splines so as not to damage the lip seal.

Assemble the casings and torque tighten the bolts.

ASSEMBLING THE CASINGS

Reassembling the seals on the differential nuts

Remove a differential nut from the casing, counting the number of turns.

ATTENTION: There are two types of seal:

1st type

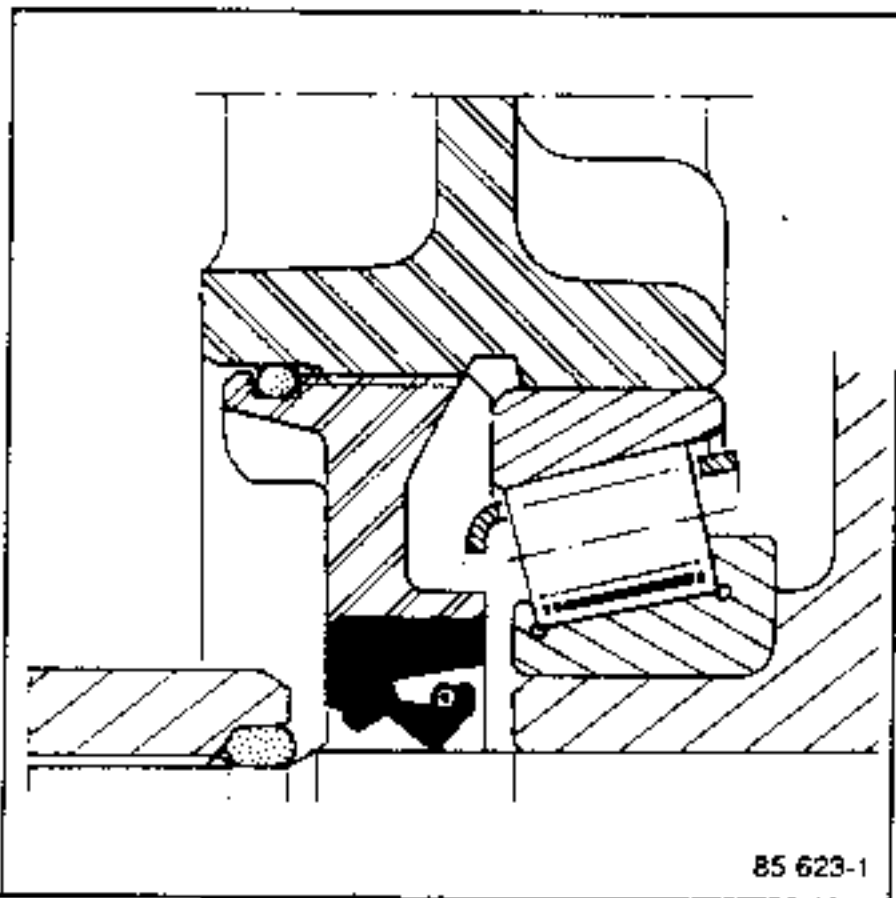

2nd type

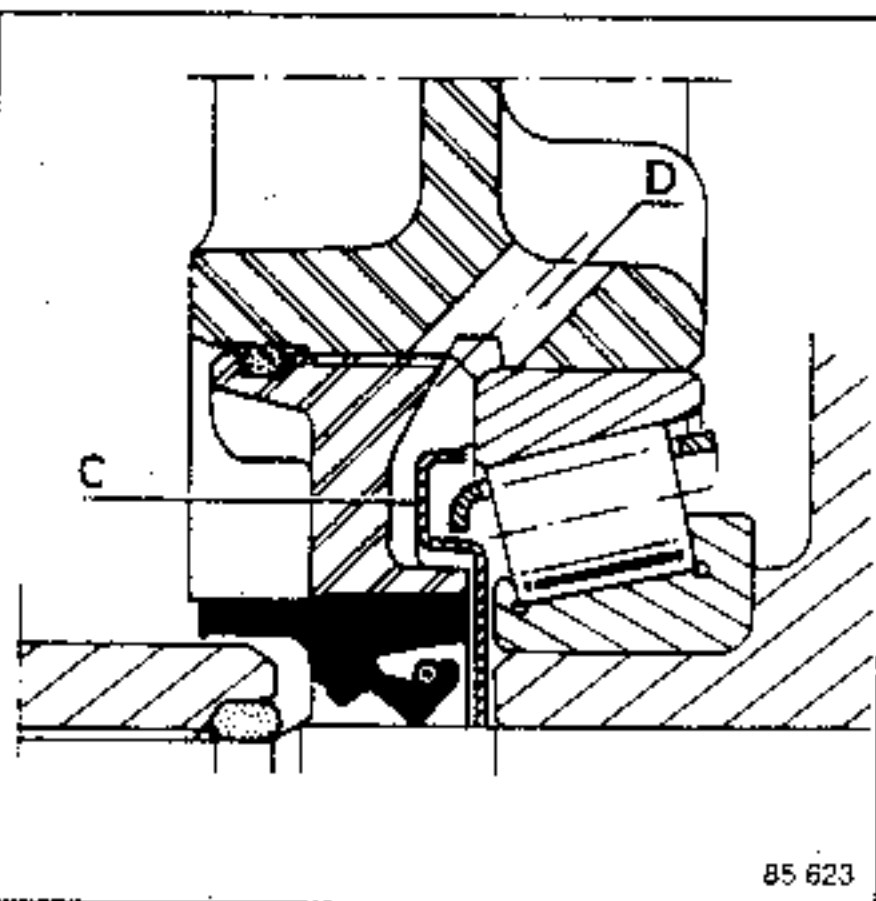

Special feature of the 2nd type:

- An oil deflector (C) has been added to the differential nut fitted to casings having an additional duct (D).
- The lip seal is of the front bush-type.

In service exchange the Parts Department supplies only:

- lip seals of the front bush-type;
- nuts with deflector (C).

IMPORTANT

Under no circumstances must deflector (C) be fitted to a manual gearbox with a casing which does not have oil way (D) since the lip seal is not lubricated.

Assembly:

On the differential nut place O-ring (A) and fit deflector (C), if necessary.

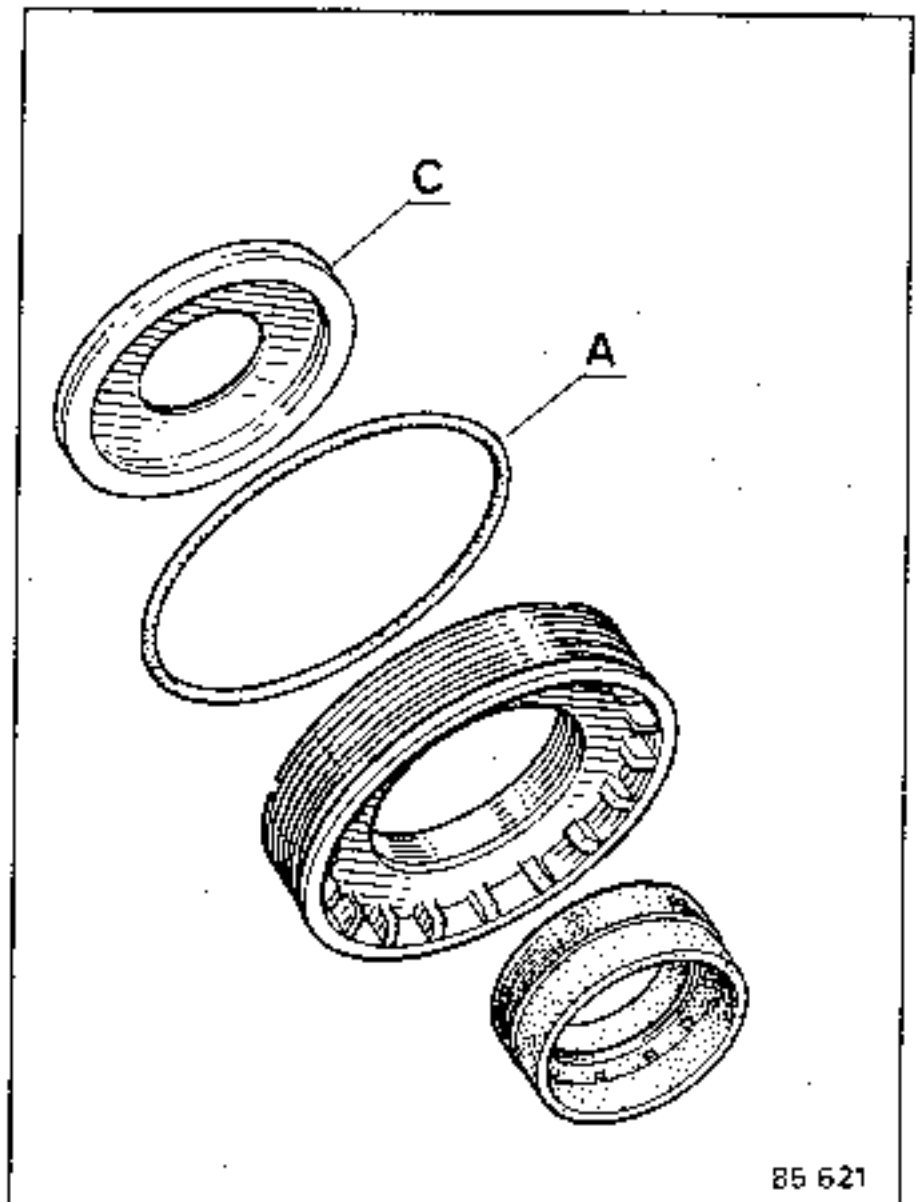

ASSEMBLING THE CASINGS

The (greased) oil seal is fitted using tool B.Vi.1154 which determines the correct position of the seal.

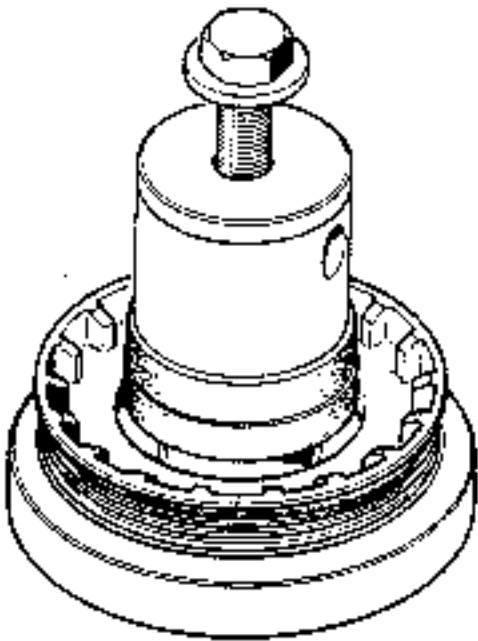

92 913

Fit tool B.Vi. 813 on the sunwheel splines.

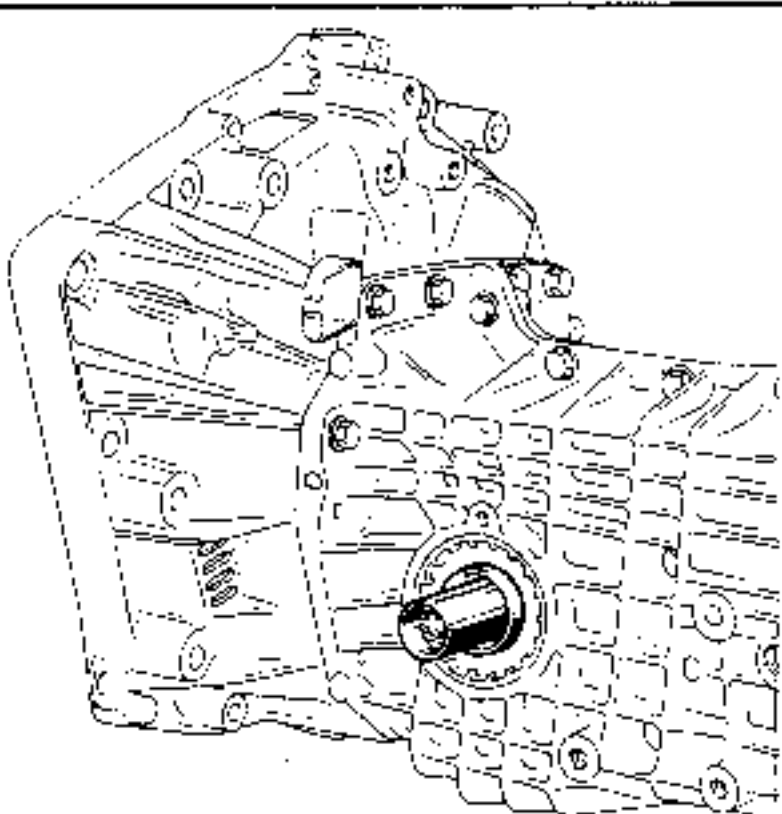

92 901 2

Using tool B.Vi.807-01, retighten the differential nut until it is aligned with the mark on the casing.

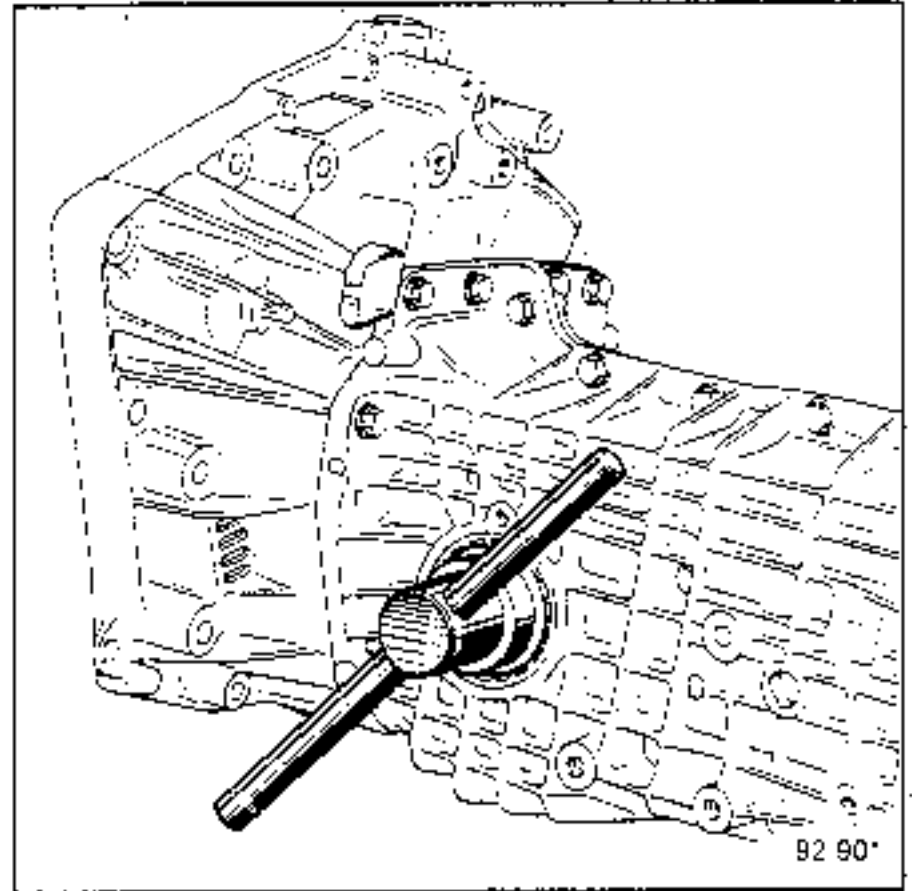

Lock the nut using the lock plate.

ASSEMBLING THE CASINGS

Lubricate the guide tube, pads and fork pivot using No. 20 grease.

"Push" type clutch

Fit the thrust pad.

Fit in place the spring, engaging its ends in the holes in the thrust pad mounting and those in the fork.

Tilt the fork and fit the new thrust pad, with notch (A) in the fork.

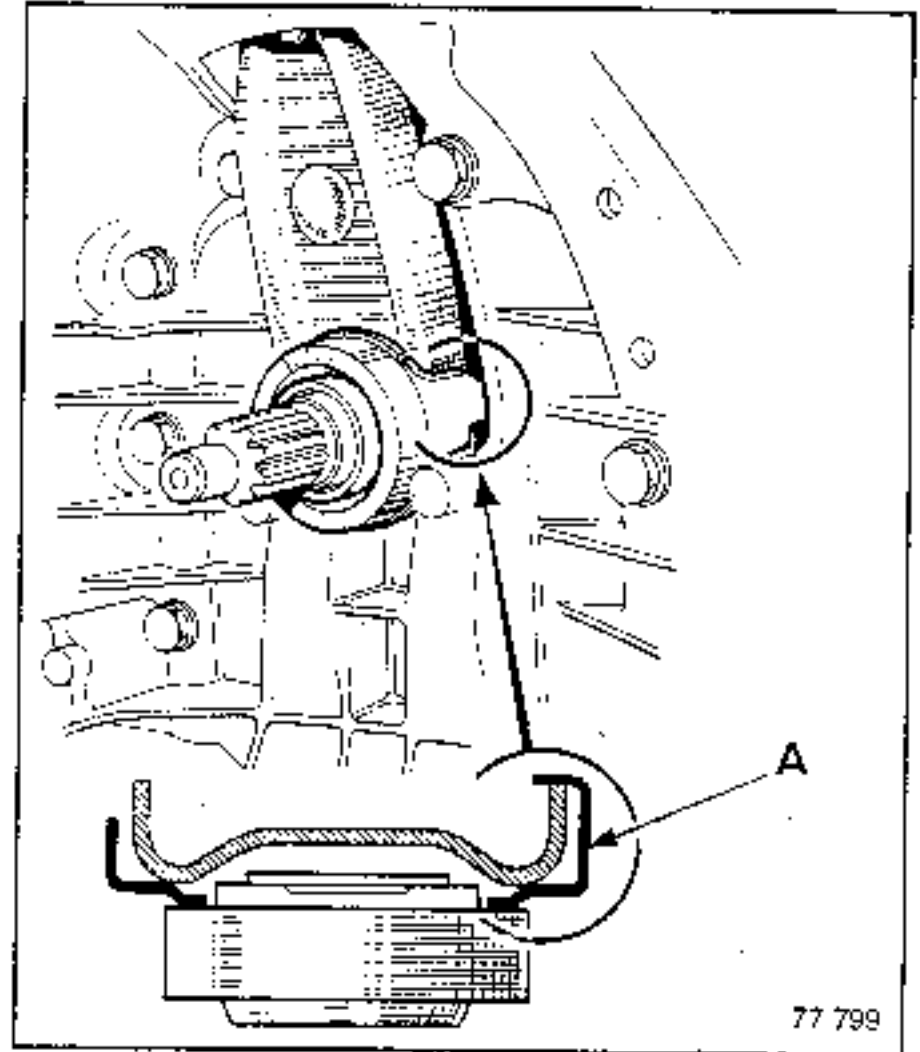
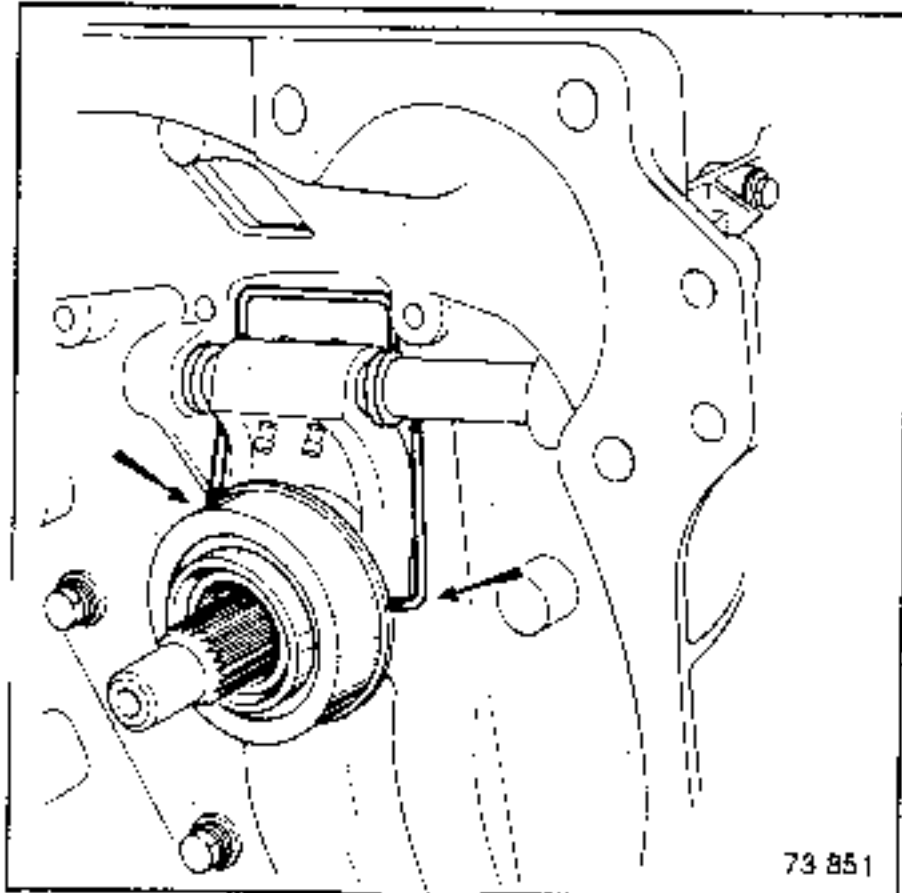

Remove the gearbox from its stand.

Before refitting the gearbox to the vehicle, fit the locating pins at (A) and (B) on the clutch casing.

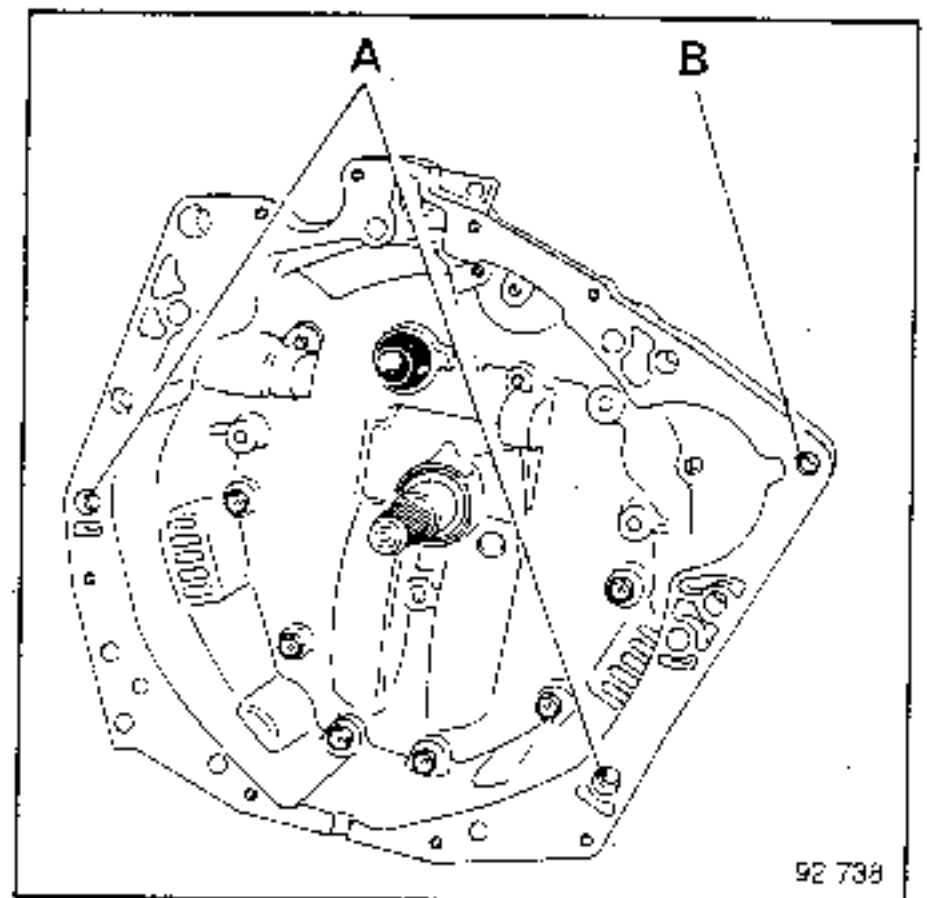

1 : Righthand half-casing	56 : Roller bearing
2 : Lefthand half-casing	57 : Grower washer
3 : Clutch casing	58 : Clutch shaft
4 : Rear casing	59 : Secondary shaft
5 : Guide tube	60 : Differential unit
6 : Differential lock nut	61 : Friction washer
7 : Lip-type seal	62 : Sunwheel
8 : O-ring	63 : Washer
9 : Reverse gear lever	64 : Planet wheel
10 : Crinkle washer	65 : Planet wheel small shaft
11 : Lever bolt	66 : Differential hub
12 : Reverse gear shaft	67 : Rollpin
13 : 1st/2nd speed shaft and fork	68 : Crown wheel
14 : Interlocking disc	69 : Collar
15 : 3rd/4th speed shaft and fork	70 : Bearing
16 : Locking spring	71 : O-ring
17 : Detent plunger ball	72 : Crown wheel bolt
18 : Locking ball	73 : Lip-type seal
19 : 1st/2nd speed locking plunger	74 : Rollpin
20 : Speedometer drive gear	75 : Selector finger rollpin
21 : Speedometer shaft	76 : Reverse gear detent plunger
22 : Speedometer seal	77 : Plunger spring
23 : Secondary shaft nut	78 : Plug
24 : Washer	79 : 1/2 shells
25 : 5th speed fixed gear	80 : Spring
26 : Spacer	81 : Selector finger
27 : Set of taper roller bearings	82 : Selector shaft-lever
28 : 4th speed idler gear	83 : Gaiter
29 : Small diameter splined washer	84 : Lip-type seal
30 : Small diameter snap ring	85 : Selector lever
31 : Synchro ring	86 : O-rings
32 : 3rd/4th speed synchro hub/slide gear	87 : Anti-dust washer
33 : 3rd/4th speed synchro ring	88 : Ball joint cover mounting lever sleeve
34 : Synchro roller	89 : Rollpins
35 : Synchro heart-shaped spring	90 : Rubber washer
36 : 3rd speed idler gear	91 : Secondary shaft nut
37 : 2nd speed idler gear	92 : Snap ring
38 : 1st/2nd speed synchro spring	93 : Drive
39 : Synchro mobile cone	94 : Needle bush
40 : 1st/2nd speed synchro hub-slide gear	95 : Slide gear
41 : Large diameter snap ring	96 : Output shaft
42 : Large diameter splined washer	97 : Lip-type seal
43 : 1st speed idler gear	98 : Bearing
44 : Cylinder roller bearing	99 : Circlip
45 : Primary shaft nut	100 : Output flange
46 : Washer	101 : Spacer
47 : 5th speed slide gear hub	102 : Flange securing bolt
48 : 5th speed synchro ring spring	103 : Dog clutch shaft
49 : 5th speed synchro	104 : Dog clutch fork
50 : 5th speed idler gear	105 : Clevis
51 : Needle bush	106 : Shaft
52 : Bush	107 : Pin
53 : Thick washer	108 : Lip-type seal
54 : Bearing with double row of balls	109 : Protector
55 : Primary shaft	110 : Vacuum capsule

Casings and controls

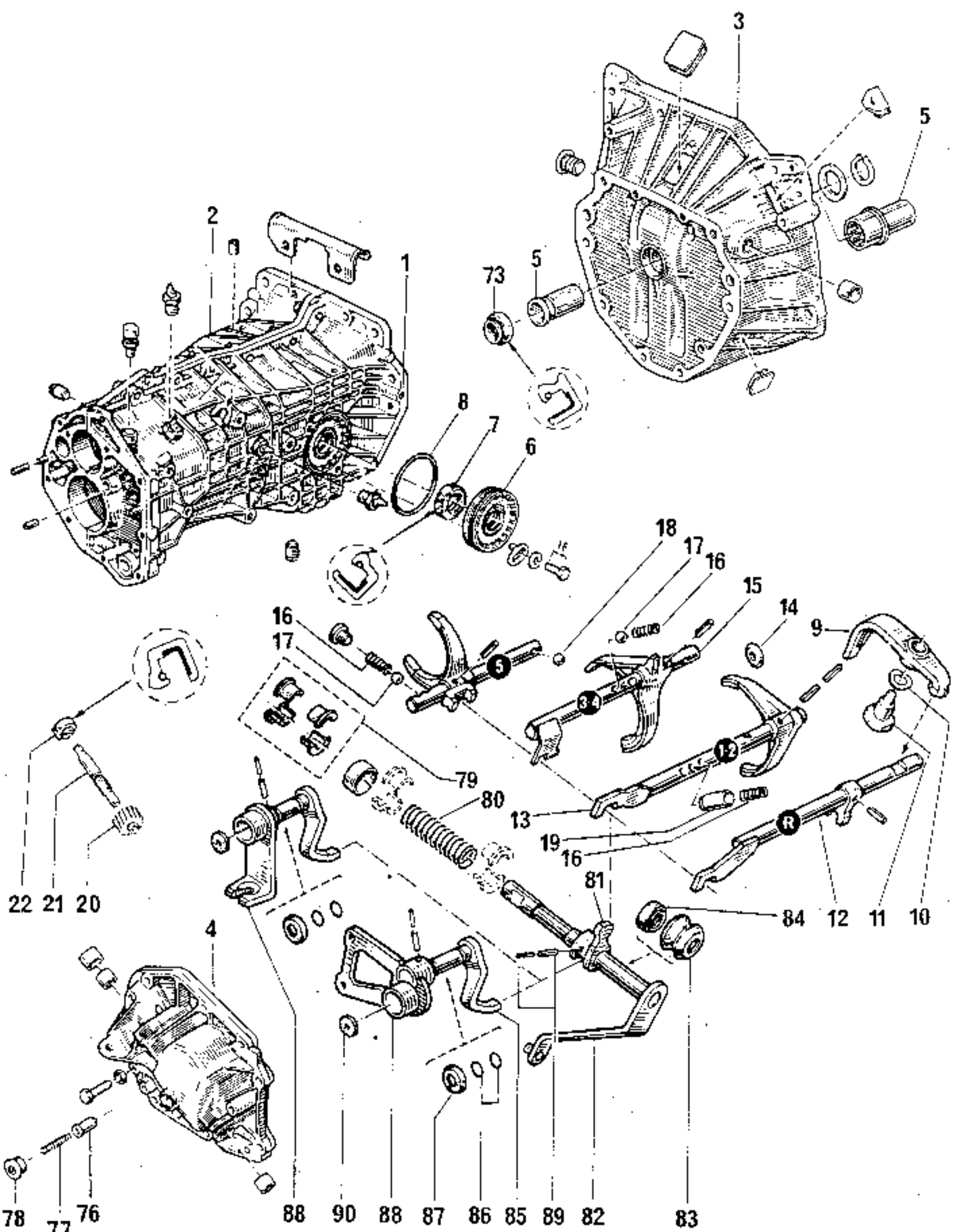

MECHANISMS

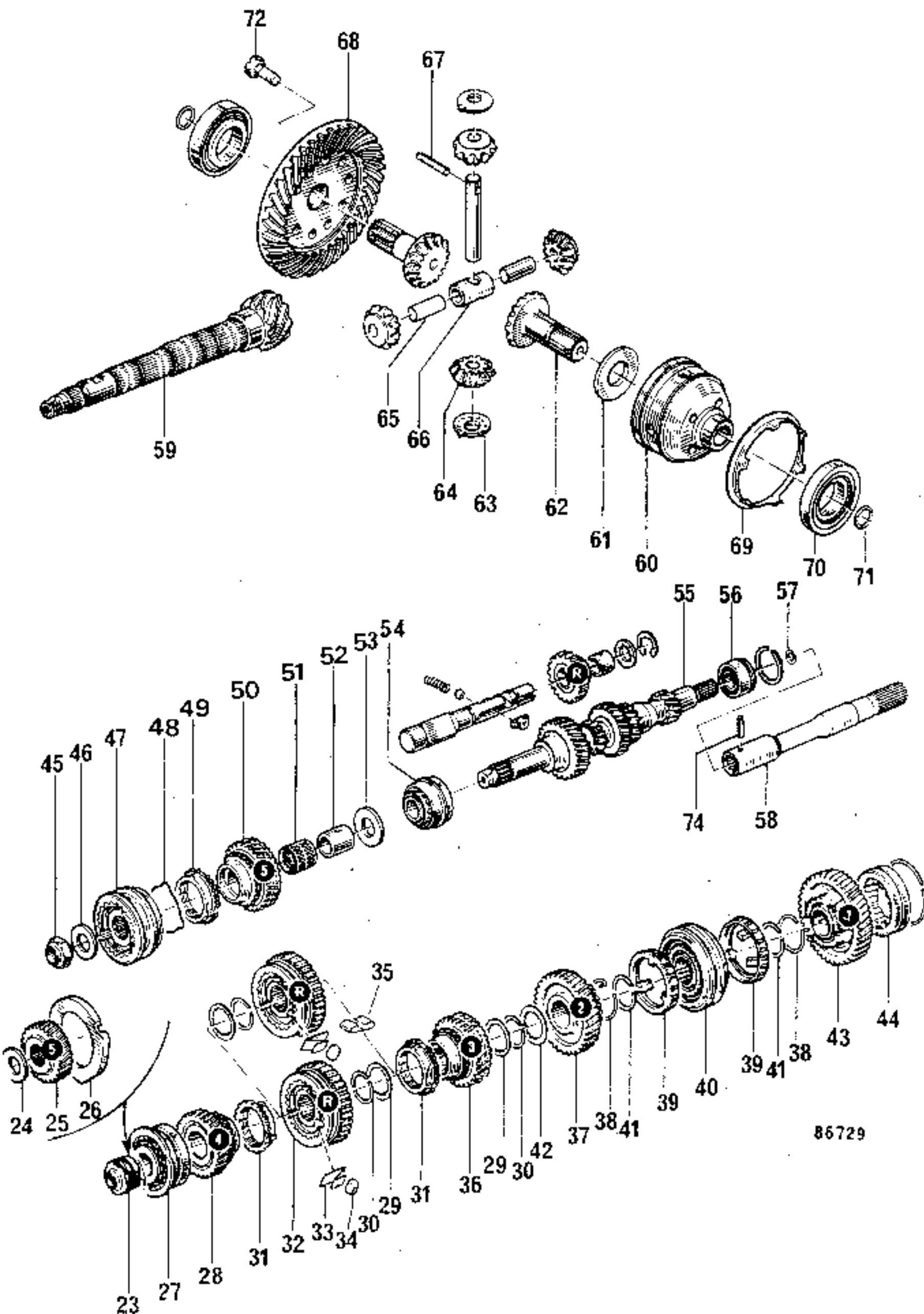

86729

Special features of NG5 gearbox

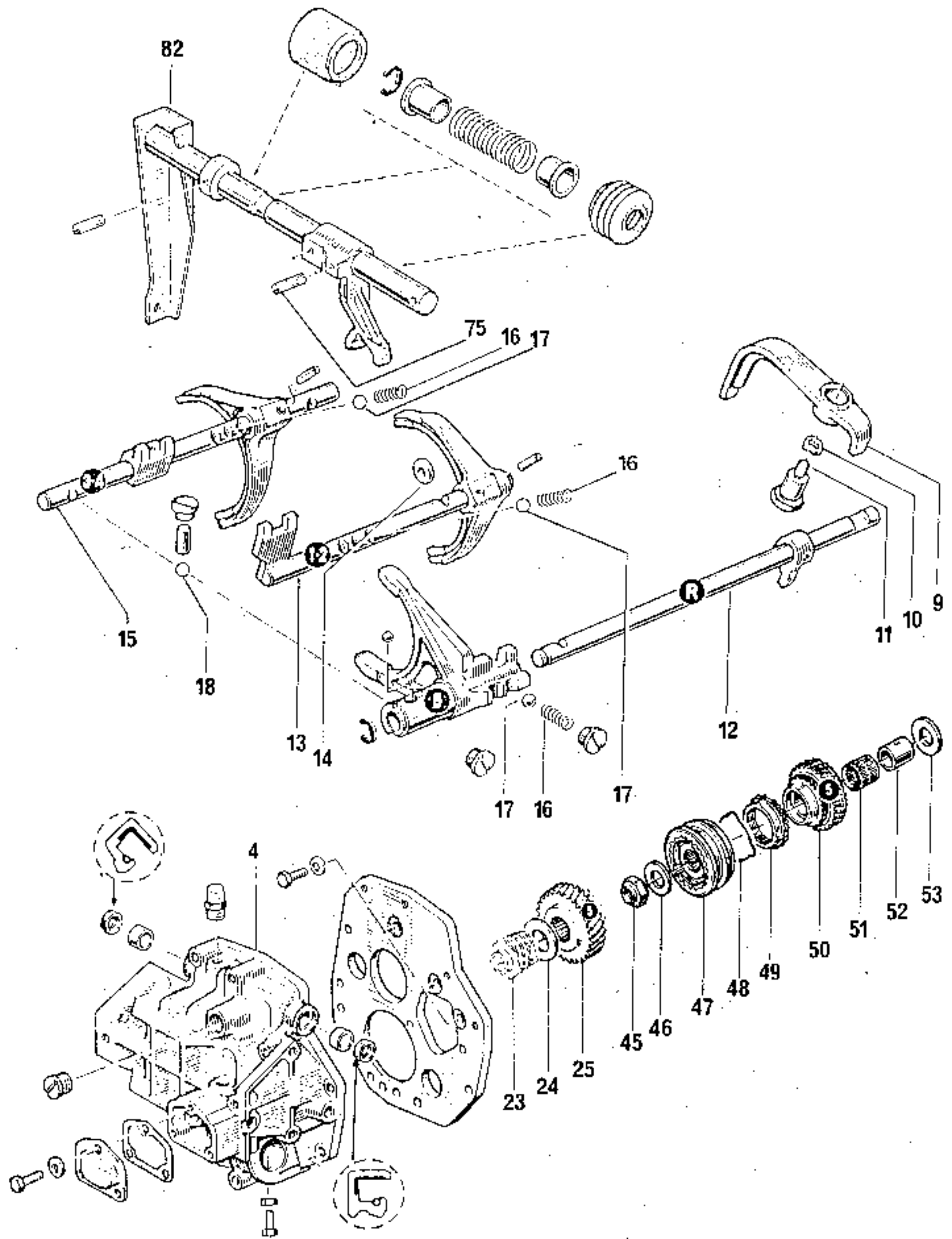

Special features of NG7 gearbox

